

TYPICAL CHARACTERISTICS

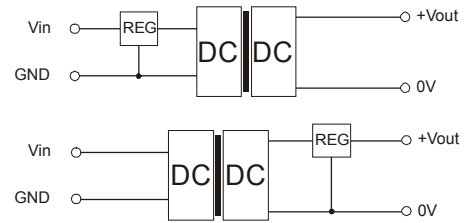

FOOTPRINT DETAILS

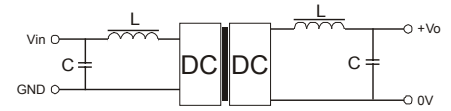
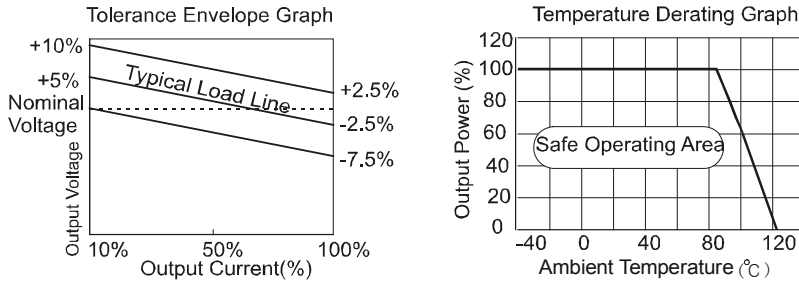
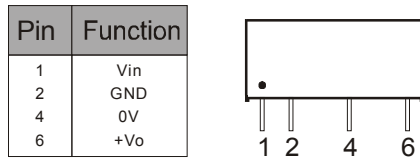

OUTLINE DIMENSIONS & RECOMMENDED FOOTPRINT

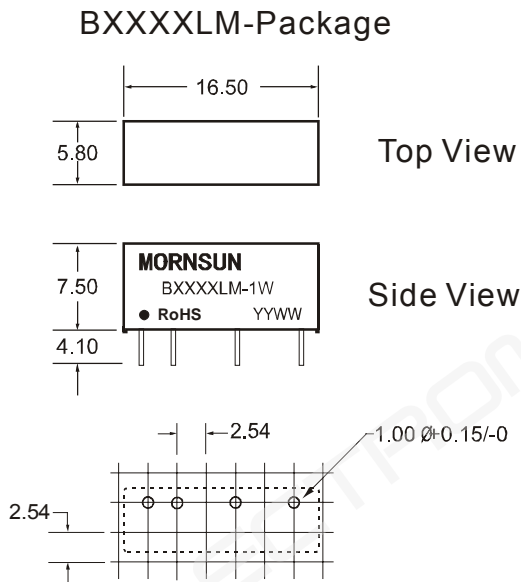

Note: All Pins on a 2.54mm pitch; All Pin diameters are 0.50 mm; all dimensions in mm.

APPLICATION NOTE

Filtering

In some circuits which are sensitive to noise and ripple, a filtering capacitor may be added to the DC/DC output end and input end to reduce the noise and ripple. However, the capacitance of the output filter capacitor must be proper. If the capacitance is too big, a startup problem might arise. For every channel of output, provided the safe and reliable operation is ensured, the greatest capacitance of its filter capacitor sees the external capacitor table. To get an extremely low ripple, an "LC" filtering network may be connected to the input and output ends of the DC/DC converter, which may produce a more significant filtering effect. It should also be noted that the inductance and the frequency of the "LC" filtering network should be staggered with the DC/DC frequency to avoid mutual interference (see figure 1).

Requirement On Output Load

To ensure this module can operate efficiently and reliably, a minimum load is specified for this kind of DC/DC converter in addition to a maximum load (namely full load). During operation, make sure the specified range of input voltage is not exceeded, the minimum output load is **not less than 10%** of the full load, and that this product should never be operated under no load! If the actual output power is very small, please connect a resistor with proper resistance at the output end in parallel to increase the load, or use our company's products with a lower rated output power (B_LM -0.25W Series).

Overload Protection

Under normal operating conditions, the output circuit of these products has no protection against over-current and short-circuits. The simplest method is to connect a self-recovery fuse in series at the input end or add a circuit breaker to the circuit.

Output Voltage Regulation and Over-voltage Protection Circuit

The simplest device for output voltage regulation, over-voltage and over-current protection is a linear voltage regulator with overheat protection that is connected to the input or output end in series (see Figure 2).

External Capacitor Table

V _{in}	External capacitor	V _{out}	External capacitor
5VDC	4.7uF	5VDC	10uF
12VDC	2.2uF	9VDC	4.7uF
24VDC	1uF	12VDC	2.2uF
--	--	15VDC	1uF



MORNSUN Science & Technology Ltd.

Address: 8th floor 8th building, Huangzhou Industrial District, Guangzhou, China
Tel: 86-20-38601850
Fax: 86-20-38601272
Http: //www.mornsun-power.com