

RoHS

B_M-1W Series

**1W, SUPERMINIATURE FIXED INPUT
ISOLATED & UNREGULATED SINGLE OUTPUT
DC-DC CONVERTER**

FEATURES

- Efficiency up to 78%
- Super miniature SIP Package
- 1KVDC Isolation
- Temperature Range: -40°C to +85°C
- UL94-V0 Package
- No Heat sink Required
- No external component required
- Industry standard pinout
- Internal SMD construction
- RoHS Compliance

APPLICATIONS

The B_M-1W Series are specially designed for applications where a single power supply is isolated from the input power supply in a distributed power supply system on a circuit board.

These products apply to:

- 1) Where the voltage of the input power supply is fixed (voltage variation $\leq \pm 10\%$);
- 2) Where isolation is necessary between input and output (isolation voltage $\leq 1000\text{VDC}$);
- 3) Where the regulation of the output voltage and the output ripple and noise are not demanding.

Such as: purely digital circuits, ordinary low frequency analog circuits and IGBT power device driven circuits, etc.

MODEL SELECTION

B0505M-1W

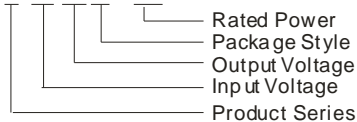

MORNSUN Science & Technology co.,Ltd.

Address: 2th floor 6th building, Huangzhou Industrial District, Guangzhou, China
Tel: 86-20-38601850
Fax: 86-20-38601272
Http://www.mornsun-power.com

PRODUCT PROGRAM

Part Number	Input		Output			Efficiency (% Typ)
	Voltage (VDC)		Voltage (VDC)	Current (mA)		
	Nominal	Range		Max	Min	
B0303M-1W	3.3	3.0-3.6	3.3	303	30	69
B0305M-1W			5	200	20	74
B0505M-1W	5	4.5-5.5	5	200	20	70
B0509M-1W *			9	111	12	76
B0512M-1W			12	83	9	77
B0515M-1W			15	67	7	78
B1205M-1W			12	10.8-13.2	5	200
B1209M-1W	9	111			12	75
B1212M-1W	12	83			9	77
B1215M-1W *	15	67			7	78

*Designing.

ISOLATION SPECIFICATIONS

Item	Test condition	Min	Typ	Max	Units
Isolation voltage	Tested for 1 minute and 1 mA max	1000			VDC
Isolation resistance	Test at 500VDC	1000			MΩ
Isolation capacitor			60		pF

OUTPUT SPECIFICATIONS

Item	Test condition	Min	Typ	Max	Units
Output power		0.1		1	W
Line regulation	For Vin change of $\pm 1\%$ (3.3V output)			± 1.5	%
	For Vin change of $\pm 1\%$ (others output)			± 1.2	
Load regulation	10% to 100% full load (3.3V output)		12	20	%
	10% to 100% full load (5V output)		10.5	15	
	10% to 100% full load (9V output)		8.3	10	
	10% to 100% full load (12V output)		6.8	10	
	10% to 100% full load (15V output)		6.3	10	
Output voltage accuracy		See tolerance envelope graph			
Temperature drift	100% full load			0.03	%/°C
Output ripple*	20MHz Bandwidth		75	100	mVp-p
Switching frequency	Full load, nominal input		100		KHz

*Test ripple and noise by "parallel cable" method. See detailed operation instructions at Testing of Power Converter section, application notes.

Note:

1. All specifications measured at TA=25°C, humidity<75%, nominal input voltage and rated output load unless otherwise specified.
2. See below recommended circuits for more details.

COMMON SPECIFICATION

Item	Test condition	Min	Typ	Max	Units
Storage humidity				95	%
Operation temperature		-40		85	°C
Storage temperature		-55		125	
Temp. rise at full load			15	25	
Lead temperature	1.5mm from case for 10 seconds			300	
Short circuit protection*				1	s
Cooling		Free air convection			
Case material		Plastic (UL94-V0)			
MTBF		3500			K hours
Weight			1.05		g

*Supply voltage must be discontinued at the end of short circuit duration.

TYPICAL CHARACTERISTICS

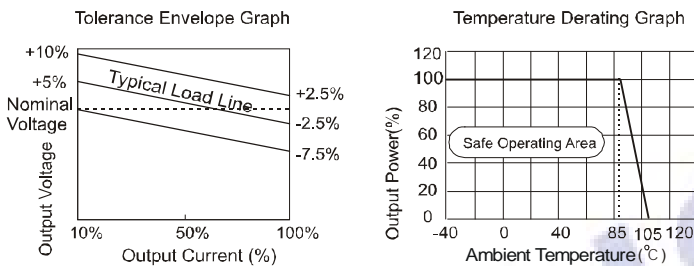

OUTLINE DIMENSIONS & PIN CONNECTIONS

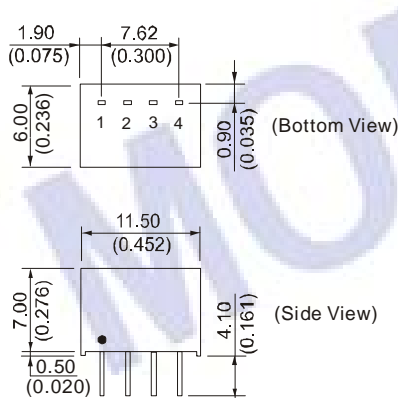

First Angle Projection

RECOMMENDED FOOTPRINT
Top view, grid: 2.54*2.54mm (0.1*0.1inch),
diameter: 1.00mm (0.039inch)

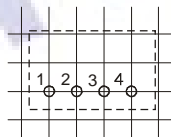

FOOTPRINT DETAILS

Pin	Function
1	GND
2	Vin
3	0V
4	+Vo

Note:

Unit:mm(inch)

Pin Section:0.50*0.30mm(0.020*0.012inch)

Pin Section tolerance:±0.10mm(±0.004inch)

General tolerances:±0.25mm(±0.010inch)

APPLICATION NOTE

Requirement On Output Load

To ensure this module can operate efficiently and reliably, a minimum load is specified for this kind of DC/DC converter in addition to a maximum load (namely full load). During operation, make sure the specified range of input voltage is not exceeded, the minimum output load is **not less than 10%** of the full load, and that this product should never be operated under no load! If the actual output power is very small, please connect a resistor with proper resistance at the output end in parallel to increase the load, or use our company's products with a lower rated output power (B_M -W2 Series).

Recommended and testing circuit

If you want to further decrease the input/output ripple, an "LC" filtering network may be connected to the input and output ends of the DC/DC converter, see (Figure 1).

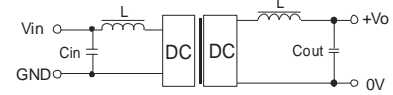

(Figure 1)

It should also be noted that the inductance and the frequency of the "LC" filtering network should be staggered with the DC/DC frequency to avoid mutual interference. However, the capacitance of the output filter capacitor must be proper. If the capacitance is too big, a startup problem might arise. For every channel of output, provided the safe and reliable operation is ensured, the recommended capacitance of its filter capacitor sees (Table 1).

EXTERNAL CAPACITOR TABLE (TABLE 1)

Vin (VDC)	Cin (uF)	Vout (VDC)	Cout (uF)
3.3/5	4.7	3.3/5	10
12	2.2	9	4.7
--	--	12	2.2
--	--	15	1

It's not recommended to connect any external capacitor in the application field with less than 0.5 watt output.

Output Voltage Regulation and Over-voltage Protection Circuit

The simplest device for output voltage regulation, over-voltage and over-current protection is a linear voltage regulator with overheat protection that is connected to the input or output end in series (see Figure 2).

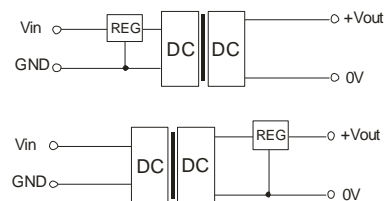

(Figure 2)

Overload Protection

Under normal operating conditions, the output circuit of these products has no protection against over-current and short-circuits. The simplest method is to connect a self-recovery fuse in series at the input end or add a circuit breaker to the circuit.

No parallel connection or plug and play.