

MORNSUN

H_RN-2W & H_LT-2W Series 2W, FIXED INPUT, ISOLATED & UNREGULATED SINGLE OUTPUT DC-DC CONVERTER



RoHS

FEATURES

- High Efficiency up to 80%
- DIP/SMD Package
- 6KVDC Isolation
- Temperature Range: -40°C to +85°C
- Internal SMD Construction
- No Heat Sink Required
- No External Component Required
- Continuous Short Circuit Protection
- Industry Standard Pinout
- RoHS Compliance

APPLICATIONS

The H_RN-2W&H_LT-2W Series are specially designed for applications where a group of polar power supplies are isolated from the input power supply in a distributed power supply system on a circuit board.

These products apply to:

- 1) Where the voltage of the input power supply is fixed (voltage variation $\leq \pm 10\%$);
- 2) Where isolation is necessary between input and output (isolation voltage $\leq 6000\text{VDC}$);
- 3) Where the regulation of the output voltage and the output ripple noise are not demanding.

Such as: purely digital circuits, ordinary low frequency analog circuits, and IGBT power device driving circuits.

MODEL SELECTION

H0505RN-2W

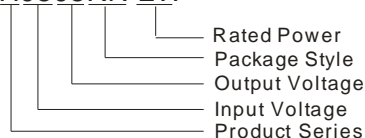

PRODUCT PROGRAM

Part Number	Input		Output			Efficiency (%. Typ.)
	Voltage (VDC)		Voltage (VDC)	Current (mA)		
	Nominal	Range		Max.	Min.	
H0505RN-2W	5	4.5-5.5	5	400	40	76
H0512RN-2W*			12	167	17	79
H0515RN-2W			15	133	13	78
H0505LT-2W			5	400	40	76
H0512LT-2W*			12	167	17	79
H0515LT-2W			15	133	13	78
H1205RN-2W*	12	10.8-13.2	5	400	40	76
H1212RN-2W*			12	167	17	80
H1215RN-2W			15	133	13	79
H1205LT-2W*			5	400	40	76
H1212LT-2W*			12	167	17	80
H1215LT-2W			15	133	13	79
H2405RN-2W*	24	21.6-26.4	5	400	40	77
H2412RN-2W*			12	167	17	80
H2415RN-2W*			15	133	13	78
H2405LT-2W*			5	400	40	77
H2412LT-2W*			12	167	17	80
H2415LT-2W*			15	133	13	78

*Designing.

COMMON SPECIFICATIONS

Item	Test Conditions	Min.	Typ.	Max.	Units
Storage humidity				95	%
Operating temperature		-40		85	°C
Storage temperature		-55		125	
Temp. rise at full load			15	25	
Lead temperature	1.5mm from case for 10 seconds			260	
Cooling		Free air convection			
Package material		Epoxy Resin (UL94-V0)			
Short circuit protection		Continuous, automatic recovery			
MTBF		3500			K hours
Weight			3.8		g

ISOLATION SPECIFICATIONS

Item	Test Conditions	Min.	Typ.	Max.	Units
Isolation voltage	Tested for 1 minute and 1mA max	6000			VDC
Isolation resistance	Test at 500VDC	1000			MΩ
Isolation capacitance			10		pF

MORNSUN Science & Technology co.,Ltd.
Address: 2th floor 6th building, Hangzhou Industrial District, Guangzhou, China
 Tel: 86-20-38601850
 Fax: 86-20-38601272
<http://www.mornsun-power.com>

OUTPUT SPECIFICATIONS					
Item	Test Conditions	Min.	Typ.	Max.	Units
Output power		0.2		2	W
Line regulation	For Vin change of 1%			±1.2	%
Load regulation	10% to 100% load (5V output)		12.8	15	
	10% to 100% load (12V output)		6.8	15	
	10% to 100% load (15V output)		6.3	15	
Output voltage accuracy		See tolerance envelope graph			
Temperature drift	100% full load			0.03	%/°C
Ripple & Noise*	20MHz Bandwidth		150	200	mVp-p
Switching frequency	Full load, nominal input		50		KHz

*Test ripple and noise by "parallel cable" method. See detailed operation instructions at Testing of Power Converter. Section, application notes.

RECOMMENDED REFLOW SOLDERING PROFILE

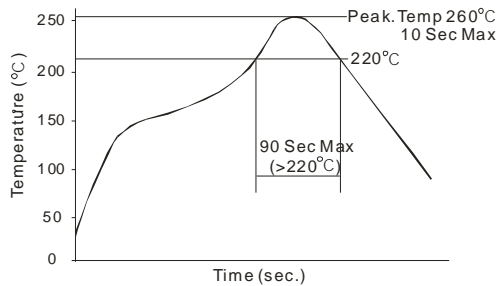

APPLICATION NOTE

1) Requirement On Output Load

To ensure this module can operate efficiently and reliably, a minimum load is specified for this kind of DC/DC converter in addition to a maximum load (namely full load). During operation, make sure the specified range of input voltage is not exceeded, the minimum output load is **not less than 10%** of the full load, and that this product should **never be operated under no load!** If the actual output power is very small, please connect a resistor with proper resistance at the output end in parallel to increase the load, or use our company's products with a lower rated output power.

2) Recommended testing and application circuit

If you want to further decrease the input/output ripple, an "LC" filtering network may be connected to the input and output ends of the DC/DC converter, see (Figure 1).

It should also be noted that the inductance and the frequency of the "LC" filtering network should be staggered with the DC/DC frequency to avoid mutual interference. However, the capacitance of the output filter capacitor must be proper. If the capacitance is too big, a startup problem might arise. For every channel of output, provided the safe and reliable operation is ensured, the recommended capacitance of its filter capacitor sees (Table 1).

3) Output Voltage Regulation and Over-voltage Protection Circuit

The simplest device for output voltage regulation, over-voltage and over-current protection is a linear voltage regulator with overheat protection that is connected to the input or output end in series (Figure 2).

4) Overload Protection

Under normal operating conditions, the output circuit of these products has no protection against overload. The simplest method is to connect a self-recovery fuse in series at the input end or add a circuit breaker to the circuit.

5) No parallel connection or plug and play

TYPICAL CHARACTERISTICS

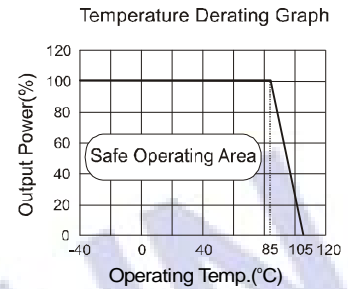
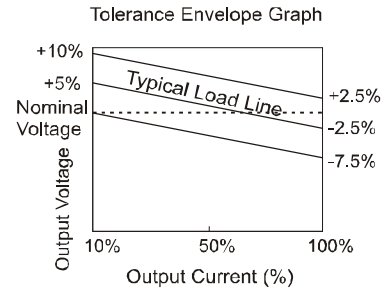

RECOMMENDED CIRCUIT

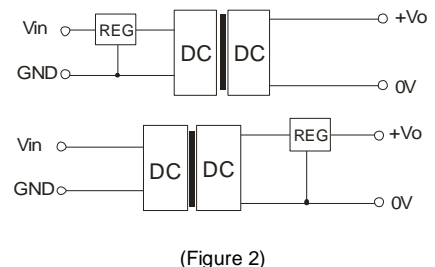
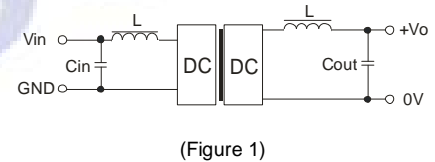

EXTERNAL CAPACITOR TABLE (TABLE 1)

Vin (VDC)	Cin (uF)	Single Vout (VDC)	Cout (uF)
5	4.7	5	10
12	2.2	12	2.2
24	1	15	1

It's not recommended to connect any external capacitor in the application field with less than 0.5 watt output.

OUTLINE DIMENSIONS & PIN CONNECTIONS

MECHANICAL DIMENSIONS

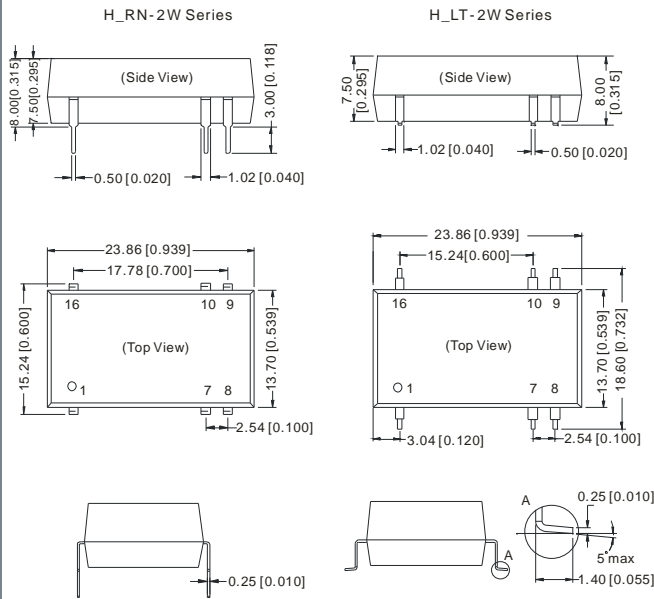

FOOTPRINT DETAILS	
Pin	Function
1	GND
7	NC
8	NC
9	+Vo
10	0V
16	Vin

NC:No Connection

Note:
Unit: mm[inch]
Pin section tolerances: ± 0.10mm [± 0.039inch]
General tolerances: ± 0.25mm [± 0.010inch]

FOOTPRINT DETAILS	
Pin	Function
1	GND
7	NC
8	NC
9	+Vo
10	0V
16	Vin

NC:No Connection

RECOMMENDED FOOTPRINT

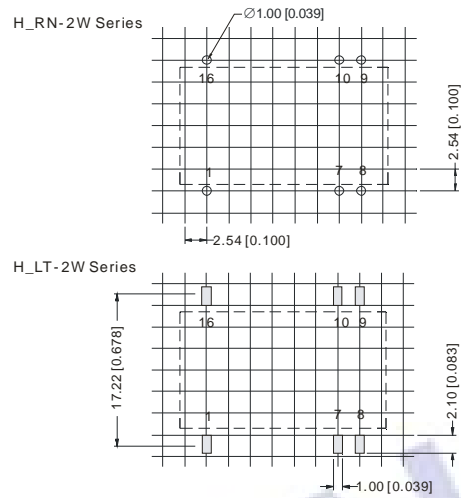

TUBE OUTLINE DIMENSIONS

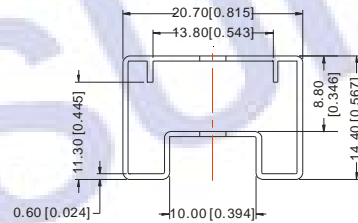

Note:
Unit :mm(inch)
General tolerances: ± 0.5mm [± 0.020inch]
L=530mm [208.66inch] Tube Quantity: 21pcs
L=220mm [86.61inch] Tube Quantity: 8pcs

Note:

1. Operation under minimum load will not damage the converter; However, they may not meet all specification listed.
2. All specifications measured at Ta=25°C, humidity<75%, nominal input voltage and rated output load unless otherwise specified.
3. In this datasheet, all the test methods of indications are based on corporate standards.
4. Only typical models listed, other models may be different, please contact our technical person for more details.