

IA_P-1W Series

**FIXED INPUT ISOLATED & REGULATED
1W OUTPUT DUAL OUTPUT
DIP PACKAGE**

RoHS
multi-country patent protection

FEATURES

- High Efficiency up to 73%
- Dual Voltage Output
- Small Footprint
- DIP Package Style
- Industry Standard Pinout
- UL94-V0 Package
- No Heat sink Required
- 1KVDC Isolation
- Power Density 0.16W/cm³
- Temperature Range: -40°C~+85°C
- No External Component Required
- RoHS Compliance

APPLICATIONS

The IA_P-1W Series are specially designed for applications where a group of polar power supplies are isolated from the input power supply in a distributed power supply system on a circuit board.

These products apply to:

- 1) Where the voltage of the input power supply is fixed (voltage variation $\leq \pm 5\%$);
- 2) Where isolation is necessary between input and output (isolation voltage = 1000VDC);
- 3) Where the regulation of the output voltage and the output ripple noise are not demanded;

These products don't apply to:

- 1) Where the input supply voltage varied (variation $\geq \pm 5\%$), otherwise our company's WRA series is recommended;

MODEL SELECTION

IA0505P-1W

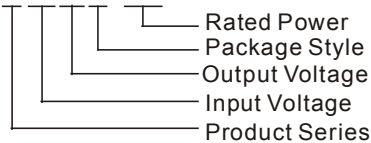

PRODUCT PROGRAM

Part Number	Input		Output			Efficiency (% Typ)	Package Style
	Voltage (VDC)		Voltage (VDC)	Current (mA)			
	Nominal	Range		Max	Min		
IA0505P-1W	5	4.75~5.25	±5	±100	±10	69	DIP
IA0509P-1W	5	4.75~5.25	±9	±56	±6	70	DIP
IA0512P-1W	5	4.75~5.25	±12	±42	±5	72	DIP
IA0515P-1W	5	4.75~5.25	±15	±33	±4	72	DIP
IA1205P-1W	12	11.4~12.6	±5	±100	±10	70	DIP
IA1209P-1W	12	11.4~12.6	±9	±56	±6	72	DIP
IA1212P-1W	12	11.4~12.6	±12	±42	±5	73	DIP
IA1215P-1W	12	11.4~12.6	±15	±33	±4	73	DIP
IA2405P-1W	24	22.8~25.2	±5	±100	±10	72	DIP
IA2409P-1W	24	22.8~25.2	±9	±56	±6	72	DIP
IA2412P-1W	24	22.8~25.2	±12	±42	±5	73	DIP
IA2415P-1W	24	22.8~25.2	±15	±33	±4	73	DIP

COMMON SPECIFICATIONS

Short circuit protection	1 second
Temperature rise at full load	25°C MAX, 15°C TYP
Cooling	Free air convection
Operating temperature range	-40°C~+85°C
Storage temperature range	-55°C ~+125°C
Lead temperature	300°C (1.5mm from case for 10 seconds)
Storage humidity range	≤ 95%
Case material	Plastic (UL94-V0)
MTBF	>3,500,000 hours

ISOLATION SPECIFICATIONS

Item	Test conditions	Min	Typ	Max	Units
Isolation voltage	Tested for 1 minute	1000			VDC
Isolation resistance	Test at 500VDC	1000			MΩ

OUTPUT SPECIFICATIONS

Item	Test conditions	MIN	TYP	MAX	Units
Output power		0.1		1	W
Line regulation	For Vin change of ±5%			0.25	%
Load regulation	10% to 100% full load			1	%
Output voltage accuracy	See tolerance envelope graph			±3	%
Temperature drift	100% full load			0.03	%/°C
Output ripple	20MHz Bandwidth		10	15	mVp-p
Switching frequency	Full load, nominal input		100		KHz

Note:

1. All specifications measured at TA=25°C, humidity<75%, nominal input voltage and rated output load unless otherwise specified.
2. See below recommended circuits for more details.



MORNSUN Science & Technology Ltd.

Address: 8th floor 8th building, Hangzhou Industrial District, Guangzhou, China
Tel: 86-20-38601850
Fax: 86-20-38601272
<http://www.mornsun-power.com>

TYPICAL CHARACTERISTICS

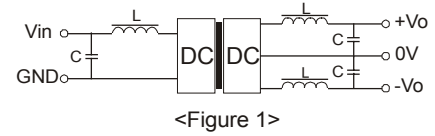
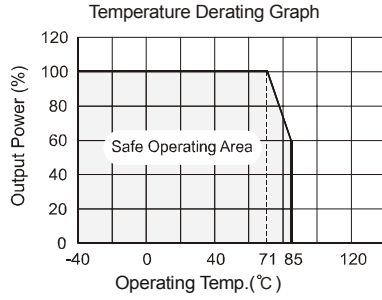

Overload Protection

Under normal operating conditions, the output circuit of these products has no protection against over-current and short-circuits. The simplest method is to connect a self-recovery fuse in series at the input end or add a circuit breaker to the circuit.

PIN CONNECTIONS

Bottom View

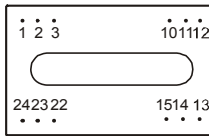

Pin	Function
1,24	V _{in}
12,13	GND
2,23	-V _o
10,15,3,22	0V
11,14	+V _o

OUTLINE DIMENSIONS & RECOMMENDED FOOTPRINT DETAILS

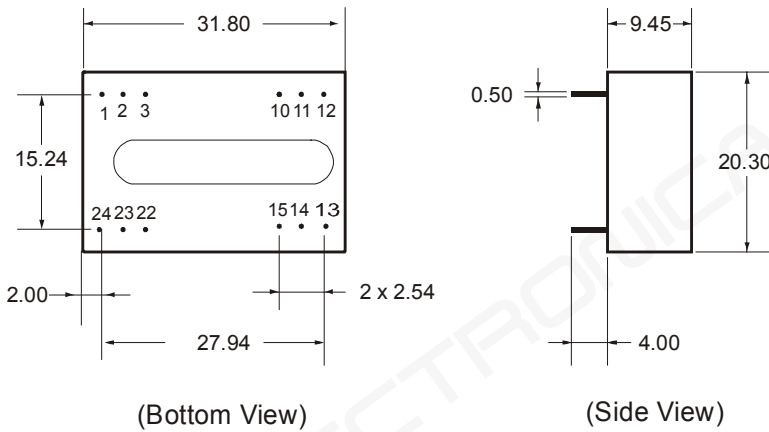

Note: All Pins on a 2.54mm pitch; all pin diameters are 0.50mm; all dimensions in mm.

External Capacitor Table

V _{in}	External capacitor	V _{out}	External capacitor
5VDC	4.7uF	5VDC	4.7uF
12VDC	2.2uF	9VDC	2.2uF
24VDC	1uF	12VDC	1uF
--	--	15VDC	0.47uF

APPLICATION NOTE

Filtering

In some circuits which are sensitive to noise and ripple, a filtering capacitor may be added to the DC/DC output end and input end to reduce the noise and ripple. However, the capacitance of the output filter capacitor must proper. If the capacitance is too big, a startup problem might arise. For every channel of output, providing the safe and reliable operation is ensured, the greatest capacitance of its filter capacitor refer to the **External Capacitor Table**. To get an extremely low ripple, an "LC" filtering network may be connected to the input and output ends of the DC/DC converter, which may produce a more significant filtering effect. It should also be noted that the inductance and the frequency of the "LC" filtering network should be staggered with the DC/DC frequency to avoid mutual interference (see figure 1).

Requirement on output load

To ensure this module can operate efficiently and reliably, a minimum load is specified for this kind of DC/DC converter in addition to a maximum load (namely full load). During operation, make sure the specified range of input voltage is not exceeded, the minimum output load is **not less than 10%** of the full load, and that this product should never be operated under no load!



MORNSUN Science & Technology Ltd.

Address: 8th floor 8th building, Huangzhou Industrial District, Guangzhou, China
 Tel: 86-20-38601850
 Fax: 86-20-38601272
 Http: //www.mornsun-power.com