



WAF150



WAD150

### APPLICATIONS

Wireless Network  
Telecom/Datacom  
Industry Control System  
Distributed Power Architectures  
Semiconductor Equipment  
Battery charger

### FEATURES

- 200 WATTS MAXIMUM OUTPUT POWER
- 4:1 WIDE INPUT RANGE
- HIGH EFFICIENCY UP TO 88%
- CV+CC MODE
- NO MINIMUM LOAD
- ADJUSTABLE OUTPUT VOLTAGE
- UNDER-VOLTAGE LOCKOUT
- INPUT REVERSE PROTECTION
- MEET EN55022 CLASS A WITHOUT EXTERNAL FILTER
- SIX-SIDED METAL SHIELDING
- WALL MOUNT APPLICATION

### OPTIONS

- Negative logic remote ON/OFF
- Heatsink
- WAD150 with EMI Filter Module

### DESCRIPTION

WAF(D)150-SERIES DC/DC converters provide up to 200 watts of output power. All model features a wide input range, adjustable output voltage and constant current mode output limit. The WAF(D)150 Converters are especially suited to telecom, networking and industrial application.

## TECHNICAL SPECIFICATION

All specifications are typical at nominal input, full load and 25°C otherwise noted

OUTPUT SPECIFICATIONS		
Output power (Rated)	Normal Vout and Iout	150 Watts
Output power (Maximum)	Vout trim to maximum and CC mode Iout	200 Watts
Voltage accuracy	Full load and nominal Vin	± 1.0%
Minimum load		0%
Voltage adjustability (Note 9)		0% ~ +20%
Line regulation	LL to HL at FL	0.2%
Load regulation	No Load to Full Load	0.4%
Temperature coefficient		±0.02% / °C, max
Transient response recovery time	25% load step change	200µs
Over voltage protection threshold	Hiccup	125% ~ 140% of Vout(nom.)
Over Load protection threshold	CC Mode (Note 10)	105% ~ 120% of Full Load
Short circuit protection		Hiccup
GENERAL SPECIFICATIONS		
Efficiency		See table
Isolation voltage	Input to Output	2250 VDC, min.
	Input to Case	1600 VDC, min.
	Output to Case	1600 VDC, min.
Isolation resistance		10 <sup>9</sup> ohms, min.
Isolation capacitance		3500pF, max.
Switching frequency		220~330KHz, Fix Frequency.
Design meet safety standard		IEC60950-1, UL60950-1, EN60950-1
Case material		Metal
Base material		Metal
Potting material		Silicon. (UL94-V0)
Dimensions	WAF150	3.86X2.560X0.67 Inch (98X65.0X17 mm)
	WAD150	3.86X2.067X0.67 Inch (98X52.5X17 mm)
Weight	WAF150	225g (7.94oz.)
	WAD150	220g (7.76oz.)
MTBF (Note 1)	BELLCORE TR-NWT-000332	1.525 x 10 <sup>6</sup> hrs
	MIL-HDBK-217F	1.353 x 10 <sup>5</sup> hrs

INPUT SPECIFICATIONS		
Input voltage range	24V Nominal input	9 – 36VDC
	48V Nominal input	18 – 75VDC
Start-up voltage	24V input	8.8VDC typ.
	48V input	17.6VDC typ.
Shutdown voltage	24V input	8.2VDC typ.
	48V input	16.2VDC typ.
Input filter		Common choke + PI type
Input surge voltage (1000mS max)	24V input	50VDC
	48V input	100VDC
Input reverse polarity protection (Note 8)		Input Parallel diode
Start up time	Nominal Vin and constant resistive load	Power up 25mS,typ.
	Remote ON/OFF	25mS,typ.
Remote ON/OFF (Note 5)		
Positive logic (standard)	DC-DC ON	Open or 3V < Vr < 12V
	DC-DC OFF	Short or 0V < Vr < 1.2V
Negative logic (option)	DC-DC ON	Short or 0V < Vr < 1.2V
	DC-DC OFF	Open or 3V < Vr < 12V
Input current of remote control pin	Nominal Vin	-0.5mA ~ 1.0mA
Remote off state input current	Nominal Vin	3.5mA

ENVIRONMENTAL SPECIFICATIONS		
Operating ambient temperature		-40°C to +85°C (with derating)
Maximum case temperature		+100°C
Storage temperature range		-55°C to +125°C
Over temperature protection (case temperature)		110°C, typ.
Thermal impedance (Note 11)	Only with baseplate	2.73°C/Watt
	With baseplate and 17mm heatsink	2.18°C/Watt
Thermal shock		MIL-STD-810F
Vibration		MIL-STD-810F
Humidity max, Non-condensing		5% ~ 95%

EMC CHARACTERISTICS			
EMI (Note 6)	EN55022		Class A
ESD	EN61000-4-2	Air	± 8KV Perf. Criteria A
		Contact	± 6KV
Radiated immunity	EN61000-4-3	10 V/m	Perf. Criteria A
Fast transient (Note 7)	EN61000-4-4	± 2KV	Perf. Criteria A
Surge (Note 7)	EN61000-4-5	± 1KV	Perf. Criteria A
Conducted immunity	EN61000-4-6	10 Vr.m.s	Perf. Criteria A





Model Number	Input Range	Output Voltage	Output Current		Output <sup>(4)</sup> Ripple & Noise	Input Current		Eff <sup>(4)</sup> (%)
			Min. load	Full load		No load <sup>(3)</sup>	Full load <sup>(2)</sup>	
WAF150-24S12W WAD150-24S12W	9 – 36 VDC	12 VDC	0mA	12.5 A	100mVp-p	70mA	7.53A	86
WAF150-24S15W WAD150-24S15W	9 – 36 VDC	15 VDC	0mA	10 A	100mVp-p	80mA	7.53A	86
WAF150-24S24W WAD150-24S24W	9 – 36 VDC	24 VDC	0mA	6.3 A	200mVp-p	95mA	7.50A	87
WAF150-24S28W WAD150-24S28W	9 – 36 VDC	28 VDC	0mA	5.4 A	200mVp-p	120mA	7.50A	87
WAF150-24S48W WAD150-24S48W	9 – 36 VDC	48 VDC	0mA	3.2 A	350mVp-p	130mA	7.71A	86
WAF150-48S12W WAD150-48S12W	18 – 75 VDC	12 VDC	0mA	12.5 A	100mVp-p	50mA	3.72A	87
WAF150-48S15W WAD150-48S15W	18 – 75 VDC	15 VDC	0mA	10 A	100mVp-p	60mA	3.72A	87
WAF150-48S24W WAD150-48S24W	18 – 75 VDC	24 VDC	0mA	6.3 A	200mVp-p	60mA	3.71A	88
WAF150-48S28W WAD150-48S28W	18 – 75 VDC	28 VDC	0mA	5.4 A	200mVp-p	70mA	3.71A	88
WAF150-48S48W WAD150-48S48W	18 – 75 VDC	48 VDC	0mA	3.2 A	350mVp-p	70mA	3.81A	87

**Note**

- BELLCORE TR-NWT-000332. Case 1: 50% Stress, Temperature at 40°C.  
MIL-HDBK-217F Notice2 @Ta=40 °C, Full load , Air Flow = 400LFM (Ground, Benign, controlled environment).
- Maximum value at nominal input voltage and full load.
- Typical value at nominal input voltage and no load.
- Typical value at nominal input voltage and full load. (20MHZ BW.)
- The remote ON/OFF control pin voltage is referenced to -Vin. The negative logic is optional.  
To order negative logic ON-OFF control adds the suffix -N (Ex: WAF150-24S24W-N).
- The WAF(D)150 series meets EN55022 class A, without external components.
- An external input filter capacitor is required if the module has to meet EN61000-4-4, EN61000-4-5.  
The filter capacitor Power Mate suggest: 24Vin : Nippon chemi-con KY series, 470µF/50V, ESR 45mΩ.  
48Vin : Nippon chemi-con KY series, 220µF/100V, ESR 48mΩ
- Internal fusing is not included, so we suggest to use an input line fuse.
- Use a resistor across on the Trim1 and Trim2 to adjust the output voltage.
- The CC Mode is Constant Current Mode. And test by nominal input voltage.
- Thermal test with iron base-plate. (The base-plate dimension is 19" \* 3.5" \* 0.063" The height is EIA standard 2U.)  
Heatsink is optional and P/N: 7G-0058A-F.

**WAF(D)150-24S12W  
Derating Curve**

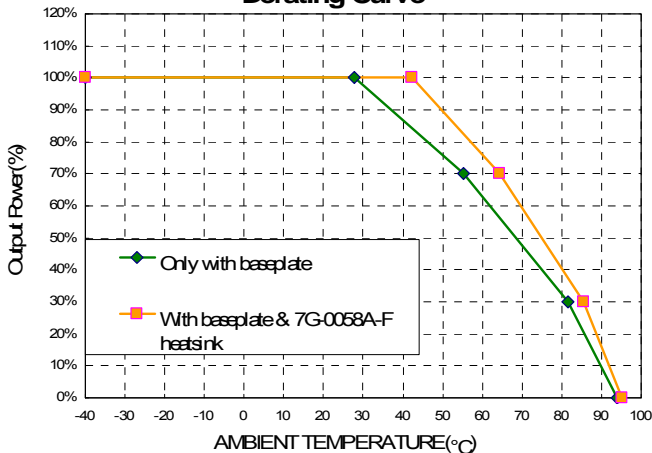

**WAF(D)150-48S24W  
Derating Curve**

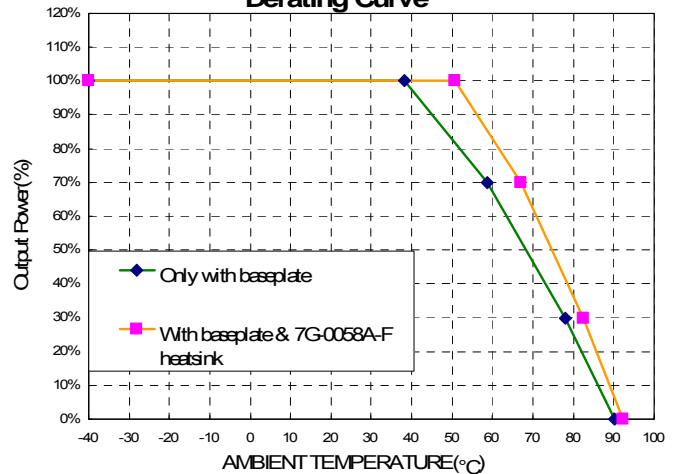



**Mechanical Drawing**

WAF150 DIMENSIONS

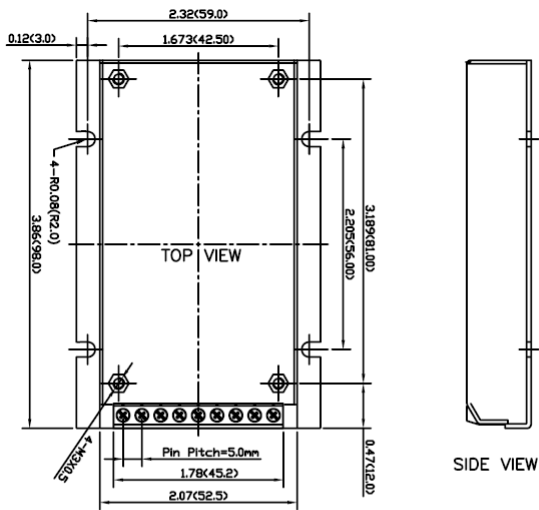

WAD150 DIMENSIONS

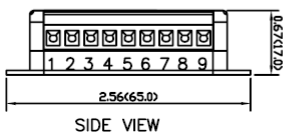
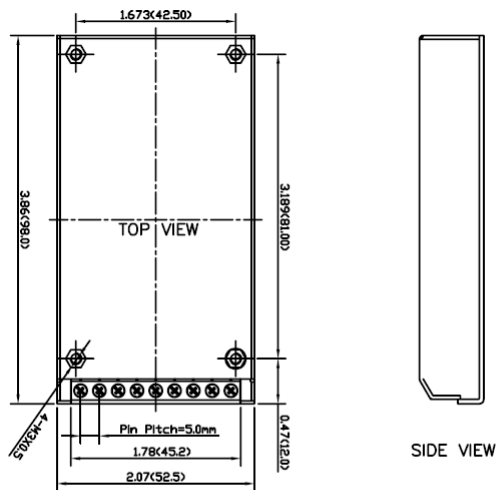

Note:1.All dimensions in Inches (mm)  
2.Pin pitch tolerance  $\pm 0.25$ mm  
3.Tolerance : x.xx $\pm 0.02$ (x.xx $\pm 0.5$ )  
x.xxx $\pm 0.01$ (x.xxx $\pm 0.25$ )  
4.Terminal Block Pin Pitch:5.0mm

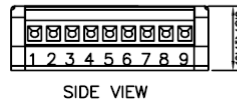

Note:1.All dimensions in Inches (mm)  
2.Pin pitch tolerance  $\pm 0.25$ mm  
3.Tolerance : x.xx $\pm 0.02$ (x.xx $\pm 0.5$ )  
x.xxx $\pm 0.01$ (x.xxx $\pm 0.25$ )  
4.Terminal Block Pin Pitch:5.0mm

WAD150 with meets EN55022 class B Filter Module (Suffix-FB)

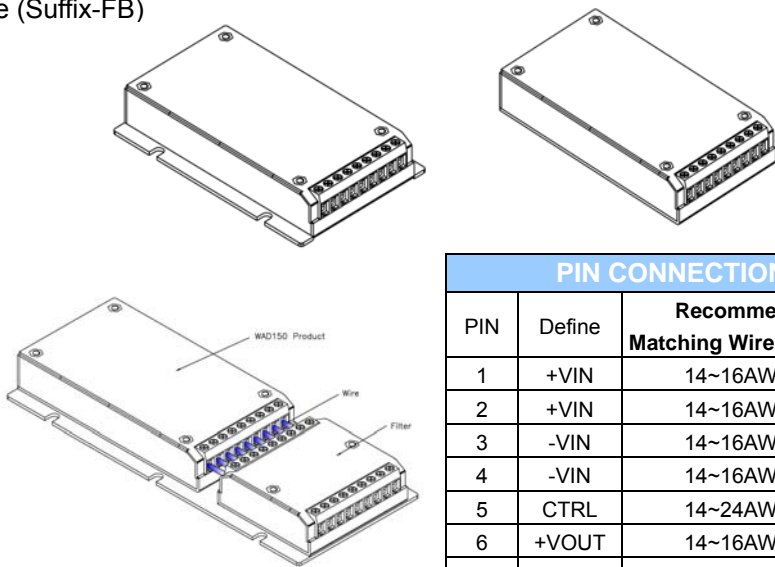
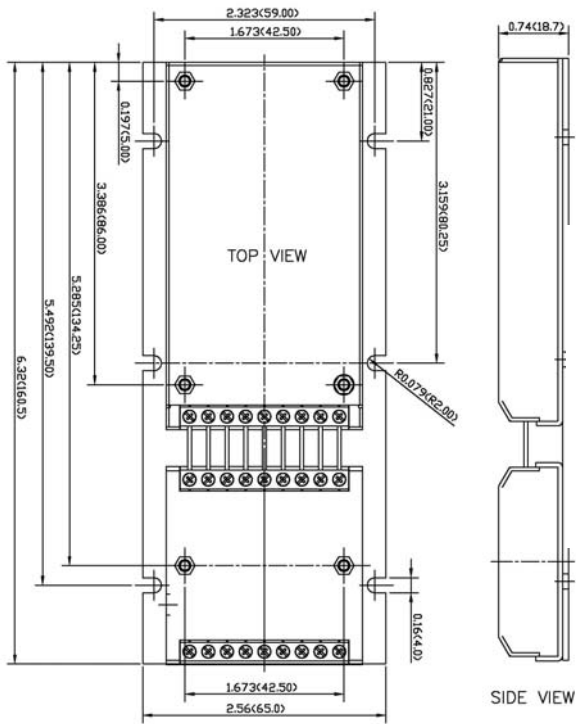

PIN CONNECTION		
PIN	Define	Recommend Matching Wire (AWG.)
1	+VIN	14~16AWG
2	+VIN	14~16AWG
3	-VIN	14~16AWG
4	-VIN	14~16AWG
5	CTRL	14~24AWG
6	+VOUT	14~16AWG
7	-VOUT	14~16AWG
8	TRIM 1	14~24AWG
9	TRIM 2	14~24AWG

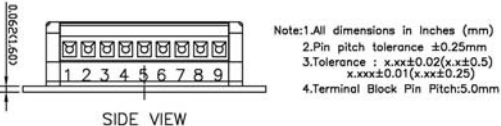
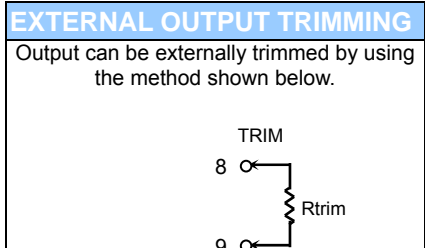

Note:1.All dimensions in Inches (mm)  
2.Pin pitch tolerance  $\pm 0.25$ mm  
3.Tolerance : x.xx $\pm 0.02$ (x.xx $\pm 0.5$ )  
x.xxx $\pm 0.01$ (x.xxx $\pm 0.25$ )  
4.Terminal Block Pin Pitch:5.0mm



HEATSINK 7G-0058A-F DIMENSIONS

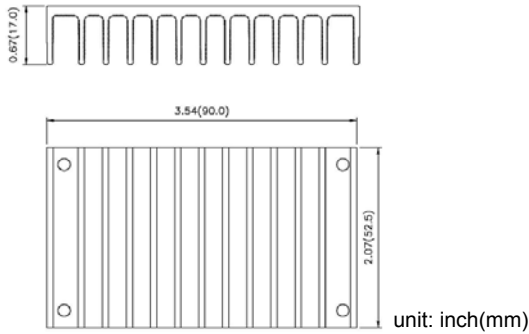

PRODUCT OPTIONS TABLE	
Option	Suffix
Positive remote ON/OFF logic	-
Negative remote ON/OFF logic	-N
With 7G-0058A-F Heatsink	-HC
With meets EN55022 class B Filter Module	-FB

Example :

- WAF150-48S12W
- WAD150-48S28W
- WAF150-24S24W-N
- WAF150-48S24W-HC
- WAD150-48S28W-FB

HEATSINK		P/N
Horizontal	H=0.670" (17mm)	7G-0058A-F

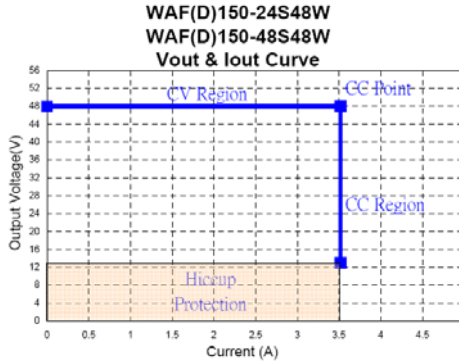
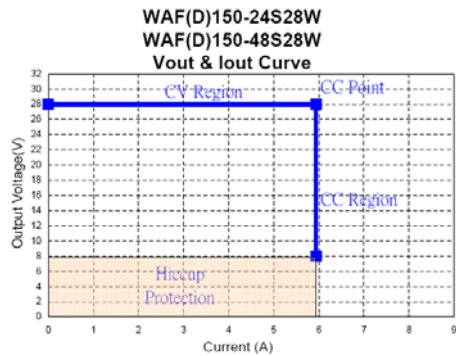
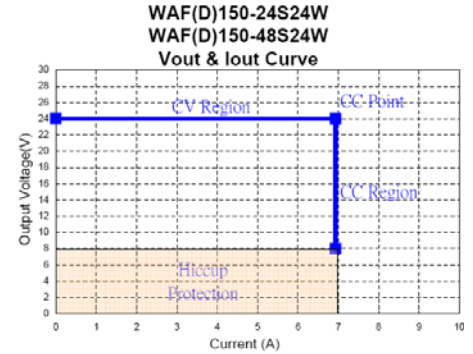
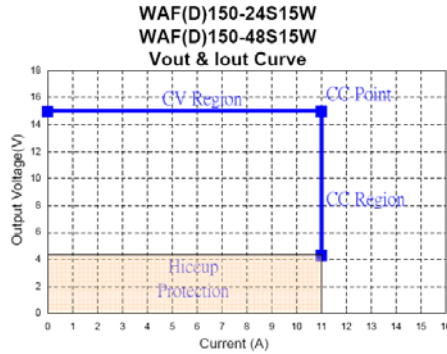
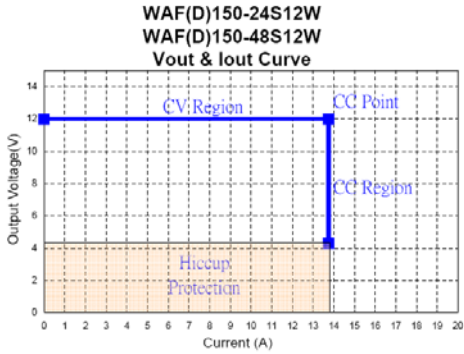

Notes:

- CV Region: In normal operation. The output current in spec.  
Condition: Resistance Load > Vout / Iout (CC Point)
- CC Region: If the output load current are over rating. The output current will keep in a constant value. And output voltage will fall.  
Condition: Resistance Load < Vout / Iout (CC Point)
- Hiccup Protection: If the output resistance is become short. It will operate in hiccup protection.  
Condition: Vout < 4.3V (typ.) to Output Short. (WAF(D)150-xxS12W,WAF(D)150-xxS15W)  
Vout < 8.0V(typ.) to Output Short. (WAF(D)150-xxS24W,WAF(D)150-xxS28W)  
Vout < 13V(typ.) to Output Short. (WAF(D)150-xxS48W)

