



## POWER SUPPLY

- AC 380-480V Wide-range Input
- Input Fuses Already Included
- Requires only Two Legs of a 3-Phase System
- Width only 40mm
- Efficiency up to 85.8%
- Input -Transient Blanking Circuit Included
- Minimal Inrush Current Surge
- Full Power Between -25°C and +60°C
- 3 Year Warranty

## GENERAL DESCRIPTION

The Dimension C-Series are cost optimized power supplies without compromising quality, reliability and performance. The C-Series is part of the DIMENSION power supply family. The most outstanding features of CT5.121 are the high efficiency, electronic inrush current limitation, active input transient filter and wide operational temperature range, the small size and other technological design concepts.

The C-Series includes all the essential basic functions. The CT5.121 utilizes only 2 legs of a 3-phase system which saves wiring and installation costs. Furthermore, this allows a smaller unit without compromising the size of the terminals. Due to the low power consumption, an unbalancing of the individual phases is not expected.

## SHORT-FORM DATA

Output voltage	DC 12V	
Adjustment range	12-15V	
Output current	8 – 6.4A	
Output power	96W	
Output ripple	< 100mVpp	20Hz to 20MHz
Input voltage	AC 380-480V	-15%/+20%
Mains frequency	50-60Hz	±6%
AC Input current	0.64 / 0.56A	at 400 / 480Vac
Power factor	0.44 / 0.42	at 400 / 480Vac
AC Inrush current	typ. 4A peak	
Efficiency	85.4 / 85.8%	at 400 / 480Vac
Losses	16.4 / 15.9W	at 400 / 480Vac
Temperature range	-25°C to +70°C	operational
Derating	2.5W/°C	+60 to +70°C
Hold-up time	typ. 33 / 58ms	at 400 / 480Vac
Dimensions	40x124x117mm	WxHxD

## ORDER NUMBERS

Power Supply	<b>CT5.121</b>	12-15V Standard unit
Accessory	ZM1.WALL	Wall mount bracket
	ZM12.SIDE	Side mount bracket
	YR2.DIODE	Decoupling module

## MARKINGS





## INDEX

	Page		Page
1. Intended Use .....	3	19. Fulfilled Standards.....	14
2. Installation Requirements.....	3	20. Used Substances .....	14
3. AC-Input.....	4	21. Physical Dimensions and Weight.....	15
4. DC-Input.....	5	22. Accessories .....	16
5. Input Inrush Current .....	5	23. Application Notes.....	17
6. Output .....	6	23.1. Peak Current Capability .....	17
7. Hold-up Time.....	7	23.2. Back-feeding Loads .....	17
8. Efficiency and Power Losses.....	8	23.3. Charging of Batteries .....	18
9. Functional Diagram.....	9	23.4. External Input Protection.....	18
10. Front Side and User Elements.....	9	23.5. Inductive and Capacitive Loads.....	18
11. Terminals and Wiring.....	10	23.6. Parallel Use to Increase Output Power....	19
12. Reliability.....	10	23.7. Parallel Use for Redundancy .....	19
13. EMC.....	11	23.8. Daisy Chaining of Outputs .....	20
14. Environment .....	12	23.9. Series Operation .....	20
15. Protection Features .....	13	23.10. Use in a Tightly Sealed Enclosure .....	20
16. Safety Features.....	13	23.11. Mounting Orientations .....	21
17. Dielectric Strength .....	13		
18. Approvals.....	14		

The information presented in this document is believed to be accurate and reliable and may change without notice.

## TERMINOLOGY AND ABBREVIATIONS

<b>PE and  symbol</b>	PE is the abbreviation for <b>Protective Earth</b> and has the same meaning as the symbol  .
<b>Earth, Ground</b>	This document uses the term "earth" which is the same as the U.S. term "ground".
<b>T.b.d.</b>	To be defined, value or description will follow later.
<b>AC 400V</b>	A figure displayed with the AC or DC before the value represents a nominal voltage with standard tolerances (usually $\pm 15\%$ ) included. E.g.: DC 12V describes a 12V battery disregarding whether it is full (13.7V) or flat (10V)
<b>400Vac</b>	A figure with the unit (Vac) at the end is a momentary figure without any additional tolerances included.
<b>50Hz vs. 60Hz</b>	As long as not otherwise stated, AC 380V and AC 400V parameters are valid at 50Hz and AC 480V parameters are valid at 60Hz mains frequency.

## 1. INTENDED USE

This device is designed for installation in an enclosure and is intended for the general use such as in industrial control, office, communication, and instrumentation equipment.

Do not use this power supply in aircrafts, trains and nuclear equipment where malfunction may cause severe personal injury or threaten human life.

This device is designed for use in non-hazardous, ordinary or unclassified locations. Do not use in hazardous location areas.

## 2. INSTALLATION REQUIREMENTS

This device may only be installed and put into operation by qualified personnel.

This device does not contain serviceable parts. The tripping of an internal fuse (if included) is caused by an internal defect.

If damage or malfunction should occur during installation or operation, immediately turn power off and send unit to the factory for inspection.

Mount the unit on a DIN-rail so that the output terminals are located on top and input terminal on the bottom. For other mounting orientations see de-rating requirements in this document.

This device is designed for convection cooling and does not require an external fan. Do not obstruct airflow and do not cover ventilation grid (e.g. cable conduits) by more than 30%!

Keep the following installation clearances: 40mm on top, 20mm on the bottom, 5mm on the left and right sides are recommended when the device is loaded permanently with more than 50% of the rated power. Increase this clearance to 15mm in case the adjacent device is a heat source (e.g. another power supply).

**⚠ WARNING** Risk of electrical shock, fire, personal injury or death.

- Do not use the power supply without proper grounding (Protective Earth). Use the terminal on the input block for earth connection and not one of the screws on the housing.
- Turn power off before working on the device. Protect against inadvertent re-powering.
- Make sure that the wiring is correct by following all local and national codes.
- Do not modify or repair the unit.
- Do not open the unit as high voltages are present inside.
- Use caution to prevent any foreign objects from entering into the housing.
- Do not use in wet locations or in areas where moisture or condensation can be expected.
- Do not touch during power-on, and immediately after power-off. Hot surface may cause burns.

## 3. AC-INPUT

AC input	nom.	AC 380-480V	
AC input range	min.	323-576Vac	continuous operation
Allowed voltage phase to earth	max.	300Vac	consult factory if one phase is earthed
Input frequency	nom.	50–60Hz	±6%
Turn-on voltage	typ.	270Vac	load independent, see Fig. 3-1
Shut-down voltage	typ.	185Vac	at 12V, 0A, see Fig. 3-1
	typ.	215Vac	at 12V, 4A
	typ.	225Vac	at 12V, 8A

		AC 400V	AC 480V	
Input current	typ.	0.64A	0.56A	at 12V, 8A, see Fig. 3-3
Power factor *)	typ.	0.44	0.42	at 12V, 8A, see Fig. 3-4
Start-up delay	typ.	75ms	75ms	see Fig. 3-2
Rise time	typ.	50ms	50ms	0mF, 12V, 8A, see Fig. 3-2
	typ.	85ms	85ms	8mF, 12V, 8A, see Fig. 3-2
Turn-on overshoot	max.	100mV	100mV	see Fig. 3-2

\*) The power factor is the ratio of the true (or real) power to the apparent power in an AC circuit.

Fig. 3-1 **Input voltage range**

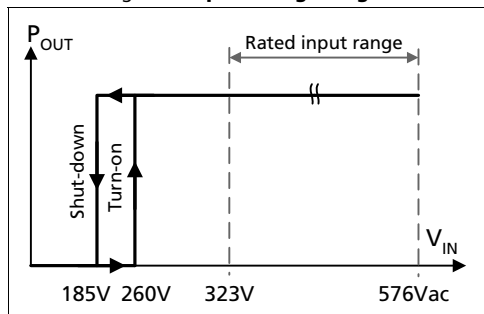


Fig. 3-2 **Turn-on behavior, definitions**

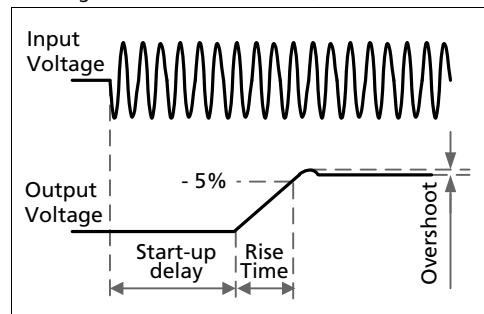


Fig. 3-3 **Input current vs. output load at 12V**

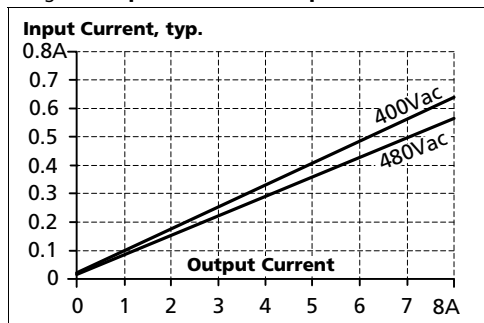
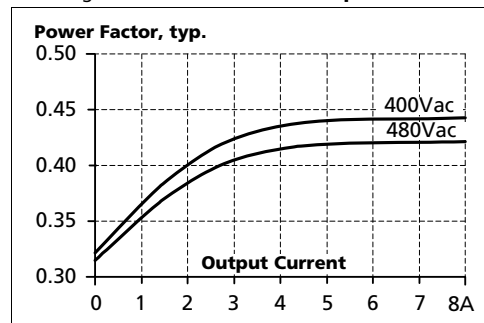


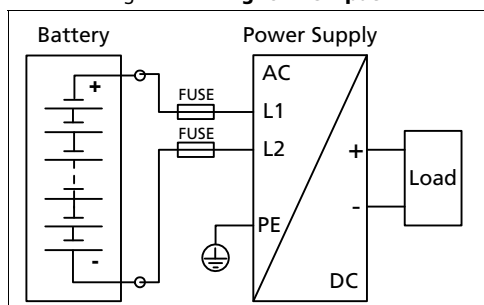
Fig. 3-4 **Power factor vs. output load**



## 4. DC-INPUT

DC input	nom.	<b>DC 600V</b>	
DC input range	min.	450-780Vdc	continuous operation
DC input current	typ.	0.24A / 0.14A	450Vdc / 780Vdc, 12V, 8A
Turn-on voltage	typ.	370Vdc	steady state value
Shut-down voltage	typ.	260Vdc	steady state value

Fig. 4-1 Wiring for DC Input



### Instructions for DC use:

- Use a battery or similar DC source.  
For other sources contact PULS
- Connect +pole to L1 and -pole to L2.
- Use appropriate external fuses in the + and - lines which are suitable for the DC-voltage.
- Connect the PE terminal to a earth wire or to the machine ground.
- DC-operation is not included in the UL approval.  
Additional testing might be necessary.

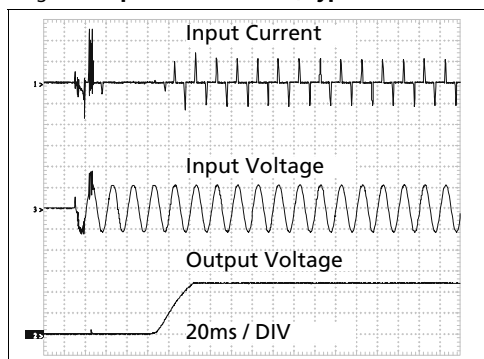
## 5. INPUT INRUSH CURRENT

An active inrush limitation circuit limits the input inrush current after turn-on of the input voltage and after short input voltage interruptions.

The charging current into EMI suppression capacitors is disregarded in the first microseconds after switch-on.

		<b>AC 400V</b>	<b>AC 480V</b>	
Inrush current	max.	10A <sub>peak</sub>	10A <sub>peak</sub>	-25°C to +70°C
	typ.	4A <sub>peak</sub>	4A <sub>peak</sub>	-25°C to +70°C
Inrush energy	max.	0.5A <sup>2</sup> s	0.5A <sup>2</sup> s	-25°C to +70°C

Fig. 5-1 Input inrush current, typical behavior



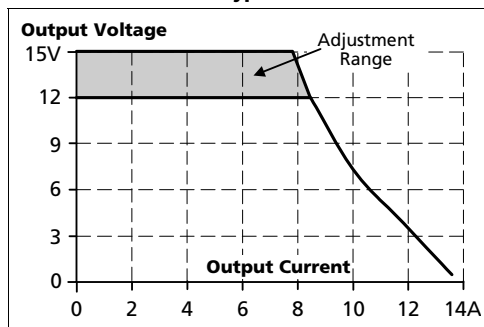
Input: 400Vac  
Output: 12V, 8A  
Ambient: 25°C

Upper curve: Input current 2A / DIV  
Middle curve: Input voltage 500V / DIV  
Lower curve: Output voltage 5V / DIV  
Time basis: 20ms / DIV

## 6. OUTPUT

Output voltage	nom.	12V	
Adjustment range	min.	12-15V	guaranteed
	max.	16.0V	at clockwise end position of potentiometer
Factory setting		12.0V	±0.2%, at full load, cold unit
Line regulation	max.	10mV	323-576Vac
Load regulation	max.	100mV	static value, 0A → 8A
Ripple and noise voltage	max.	100mVpp	20Hz to 20MHz, 50Ohm
Output capacitance	typ.	5 200µF	
Output current	nom.	8A	at 12V, see Fig. 6-1
	nom.	6.4A	at 15V, see Fig. 6-1
Output power	nom.	96W	
Short-circuit current	min.	12A	continuous current, short circuit impedance 100mOhm
	max.	15A	Continuous current, short circuit impedance 100mOhm

Fig. 6-1 **Output voltage vs. output current, typ.**



### Peak current capability (up to several milliseconds)

The power supply can deliver a peak current which is higher than the specified short term current. This helps to start current demanding loads or to safely operate subsequent circuit breakers.

The extra current is supplied by the output capacitors inside the power supply. During this event, the capacitors will be discharged and causes a voltage dip on the output. Detailed curves can be found in chapter 23.1.

Peak current voltage dips	typ.	from 12V to 7V	at 16A for 50ms, resistive load
	typ.	from 12V to 7V	at 40A for 2ms, resistive load
	typ.	from 12V to 3.7V	at 40A for 5ms, resistive load

## 7. HOLD-UP TIME

		<b>AC 400V</b>	<b>AC 480V</b>	
Hold-up Time	typ.	33ms	58ms	at 12V, 8A, see Fig. 7-1
	typ.	63ms	110ms	at 12V, 4A, see Fig. 7-1

Fig. 7-1 **Hold-up time vs. input voltage**

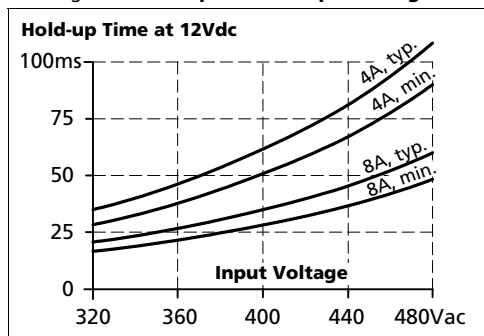
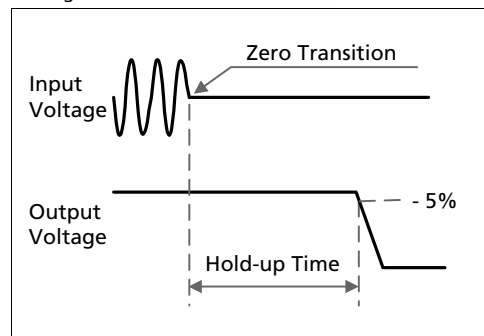


Fig. 7-2 **Shut-down behavior, definitions**



## 8. EFFICIENCY AND POWER LOSSES

		<b>AC 400V</b>	<b>AC 480V</b>	
Efficiency	typ.	85.4%	85.8%	at 12V, 8A
Average efficiency *)	typ.	84.7%	84.1%	25% at 2A, 25% at 4A, 25% at 6A. 25% at 8A
Power losses	typ.	1.5W	1.6W	at 0A
		8.4W	9.1W	at 12V, 4A
	typ.	16.4W	15.9W	at 12V, 8A

\*) The average efficiency is an assumption for a typical application where the power supply is loaded with 25% of the nominal load for 25% of the time, 50% of the nominal load for another 25% of the time, 75% of the nominal load for another 25% of the time and with 100% of the nominal load for the rest of the time.

Fig. 8-1 **Efficiency vs. output current at 12V, typ.**

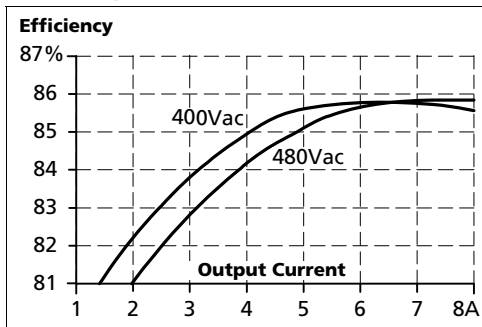


Fig. 8-2 **Losses vs. output current at 12V, typ.**

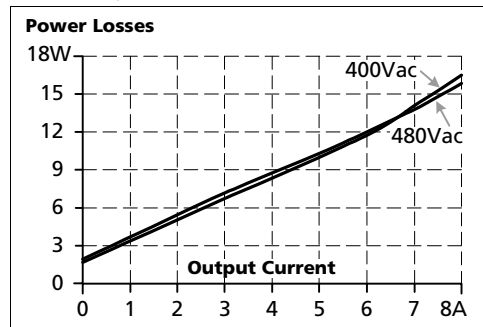


Fig. 8-3 **Efficiency vs. input voltage at 12V, 8A, typ.**

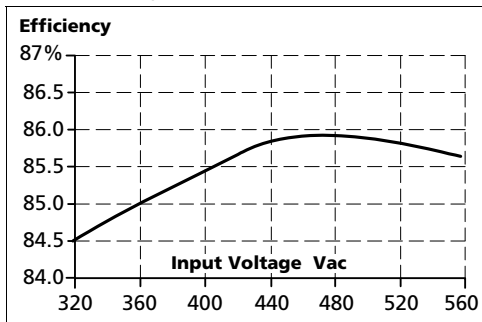
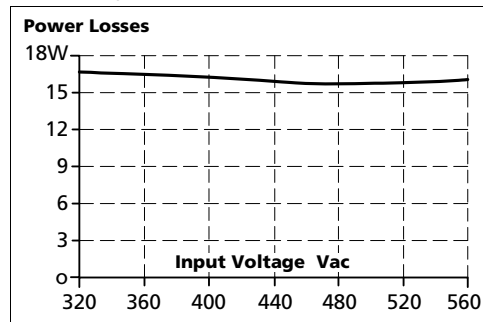
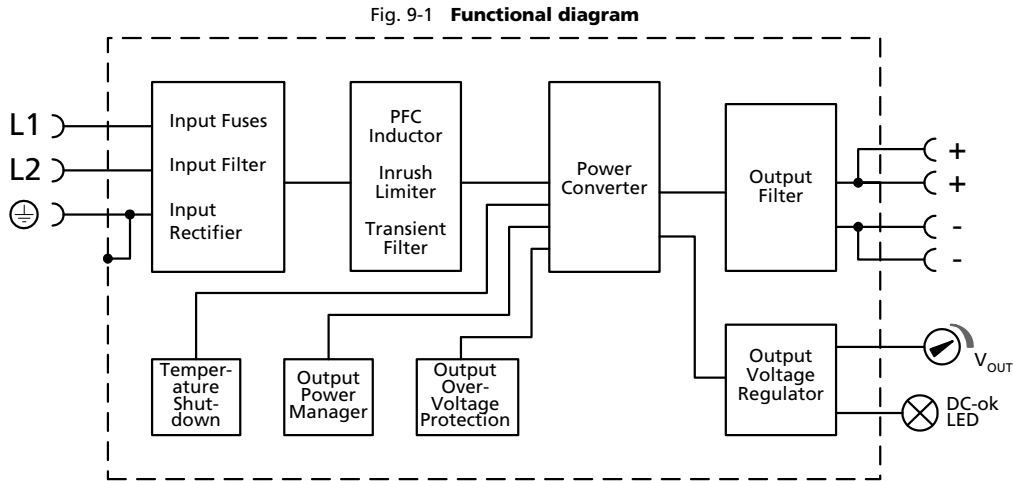


Fig. 8-4 **Losses vs. input voltage at 12V, 8A, typ.**



### 9. FUNCTIONAL DIAGRAM



### 10. FRONT SIDE AND USER ELEMENTS

Fig. 10-1 **Front side**



- A** Output Terminals  
Screw terminals, dual terminals per pole  
+ Positive output  
- Negative (return) output
- B** Input Terminals  
Screw terminals  
L1, L2 Phase input  
⊕ PE (Protective Earth) input
- C** Output voltage potentiometer  
Open the flap to set the output voltage. Factory set: 12.0V
- D** DC-OK LED (green)  
On when the voltage on the output terminals is > 10.5V

## 11. TERMINALS AND WIRING

	<b>Input</b>	<b>Output</b>
<b>Type</b>	screw terminals	screw terminals
Solid wire	0.5-6mm <sup>2</sup>	0.5-6mm <sup>2</sup>
Stranded wire	0.5-4mm <sup>2</sup>	0.5-4mm <sup>2</sup>
American Wire Gauge	20-10 AWG	20-10 AWG
Wire stripping length	7mm / 0.275inch	7mm / 0.275inch
Screwdriver	3.5mm slotted or Pozidrive No 2	3.5mm slotted or Pozidrive No 2
Recommended tightening torque	0.8Nm, 7lb.in	0.8Nm, 7lb.in

### Instructions:

- a) Use appropriate copper cables that are designed for an operating temperature of: 60°C for ambient up to 45°C and 75°C for ambient up to 60°C minimum.
- b) Follow national installation codes and installation regulations!
- c) Ensure that all strands of a stranded wire enter the terminal connection!
- d) Up to two stranded wires with the same cross section are permitted in one connection point (except PE wire).
- e) Do not use the unit without PE connection.
- f) Screws of unused terminal compartments should be securely tightened.
- g) Ferrules are allowed, but not required

## 12. RELIABILITY

	<b>AC 400V</b>	<b>AC 480V</b>	
Lifetime expectancy *)	51 000h	55 000h	at 12V, 8A and 40°C
	152 000h	147 000h	at 12V, 4A and 40°C
	144 000h	156 000h	at 12V, 8A and 25°C
MTBF **) SN 29500, IEC 61709	T.B.D.	T.B.D.	at 12V, 8A and 40°C
	T.B.D.	T.B.D.	at 12V, 8A and 25°C
MTBF **) MIL HDBK 217F	T.B.D.	T.B.D.	at 12V, 8A and 40°C; Ground Benign GB40
	T.B.D.	T.B.D.	at 12V, 8A and 25°C; Ground Benign GB25

\*) The **Lifetime expectancy** shown in the table indicates the minimum operating hours (service life) and is determined by the lifetime expectancy of the built-in electrolytic capacitors. Lifetime expectancy is specified in operational hours and is calculated according to the capacitor's manufacturer specification. The prediction model allows only a calculation of up to 15 years from date of shipment.

\*\*) **MTBF** stands for **Mean Time Between Failure**, which is calculated according to statistical device failures, and indicates reliability of a device. It is the statistical representation of the likelihood of a unit to fail and does not necessarily represent the life of a product.

## 13. EMC

The power supply is suitable for applications in industrial environment as well as in residential, commercial and light industry environment without any restrictions. The CE mark indicates conformance with EMC guideline 89/336/EEC, 93/68/EEC and 2004/108/EC and the low-voltage directive (LVD) 73/23/EWG and 2006/95/EC. A detailed EMC report is available on request.

<b>EMC Immunity</b>	Generic standards: EN 61000-6-1 and EN 61000-6-2			
Electrostatic discharge	EN 61000-4-2	Contact discharge	8kV	Criterion A
		Air discharge	15kV	Criterion A
Electromagnetic RF field	EN 61000-4-3	80MHz-2.7GHz	10V/m	Criterion A
Fast transients (Burst)	EN 61000-4-4	Input lines	4kV	Criterion A
		Output lines	2kV	Criterion A
Surge voltage on input	EN 61000-4-5	L1 → L2	2kV	Criterion A
Surge voltage on input	EN 61000-4-5	L1 → PE, L2 → PE	4kV	Criterion A
Surge voltage on output	EN 61000-4-5	+ → -	500V	Criterion A
		+ / - → PE	500V	Criterion A
Conducted disturbance	EN 61000-4-6	0.15-80MHz	10V	Criterion A
Mains voltage dips	EN 61000-4-11	0% of 380Vac	0Vac, 20ms	Criterion A
		0% of 480Vac	0Vac, 20ms	Criterion A
Mains voltage dips	EN 61000-4-11	40% of 380Vac	200ms	Criterion C
		40% of 480Vac	200ms	Criterion C
		70% of 380Vac	500ms	Criterion A
		70% of 480Vac	500ms	Criterion A
Voltage interruptions	EN 61000-4-11		0Vac, 5000ms	Criterion C
Voltage sags	SEMI F47 0706	80% of 380Vac, load: 12V, 4A	1000ms	Criterion A
		70% of 380Vac, load: 12V, 4A	500ms	Criterion A
		50% of 380Vac, load: 12V, 4A	200ms	Criterion A
Voltage sags	SEMI F47 0706	80% of 480Vac, load: 12V, 8A	1000ms	Criterion A
		70% of 480Vac, load: 12V, 8A	500ms	Criterion A
		50% of 480Vac, load: 12V, 8A	200ms	Criterion A
Powerful transients	VDE 0160	over entire load range	1550V, 1.3ms	Criterion A

**Criteria:**

- A:** Power supply shows normal operation behavior within the defined limits.
- C:** Temporary loss of function is possible. Power supply may shut-down and restarts by itself. No damage or hazards for the power supply will occur.

<b>EMC Emission</b>	Generic standards: EN 61000-6-3 and EN 61000-6-4	
Conducted emission	EN 55011, EN 55022, FCC Part 15, CISPR 11, CISPR 22	Class B, input lines
Radiated emission	EN 55011, EN 55022	Class B
Harmonic input current	EN 61000-3-2	fulfilled
Voltage fluctuations, flicker	EN 61000-3-3	fulfilled

This device complies with FCC Part 15 rules.

Operation is subjected to following two conditions: (1) this device may not cause harmful interference, and (2) this device must accept any interference received, including interference that may cause undesired operation.

**Switching frequency** Variable between 45kHz and 170kHz depending on load and input voltage

## 14. ENVIRONMENT

Operational temperature *)	-25°C to +70°C (-13°F to 158°F)	Reduce output power according Fig. 14-1
Storage temperature	-40 to +85°C (-40°F to 185°F)	For storage and transportation
Output de-rating	2.5W/°C	60-70°C (140°F to 158°F)
Humidity **)	5 to 95% r.H.	IEC 60068-2-30
Vibration sinusoidal	2-17.8Hz: ±1.6mm; 17.8-500Hz: 2g 2 hours / axis	IEC 60068-2-6
Shock	30g 6ms, 20g 11ms 3 bumps / direction, 18 bumps in total	IEC 60068-2-27
Altitude	0 to 6000m (0 to 20 000ft)	Reduce output power or ambient temperature above 2000m sea level.
Altitude de-rating	6W/1000m or 5°C/1000m	above 2000m (6500ft), see Fig. 14-2
Over-voltage category	III	IEC 62103, EN 50178, altitudes up to 2000m
	II	Altitudes from 2000m to 6000m
Degree of pollution	2	IEC 62103, EN 50178, not conductive

\*) Operational temperature is the same as the ambient temperature and is defined as the air temperature 2cm below the unit.

\*\*\*) Do not energize while condensation is present

Fig. 14-1 **Output current vs. ambient temp.**

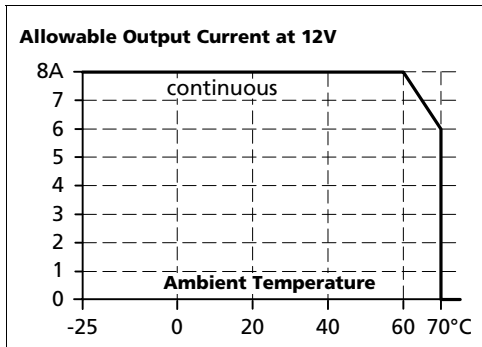
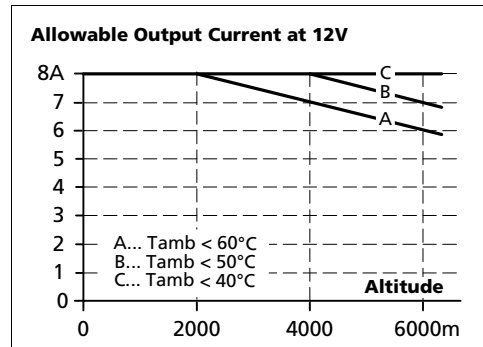


Fig. 14-2 **Output current vs. altitude at 12V**



## 15. PROTECTION FEATURES

Output protection	Electronically protected against overload, no-load and short-circuits *)	
Output over-voltage protection	typ. 18Vdc max. 20Vdc	In case of an internal power supply defect, a redundant circuit limits the maximum output voltage. The output shuts down and automatically attempts to restart.
Degree of protection	IP 20	EN/IEC 60529
Penetration protection	> 3.5mm	e.g. screws, small parts
Over-temperature protection	yes	Output shut-down with automatic restart
Input transient protection	MOV (Metal Oxide Varistor) and active transient filter	
Internal input fuse	2x T3.15A H.B.C.	not user replaceable

\*) In case of a protection event, audible noise may occur.

## 16. SAFETY FEATURES

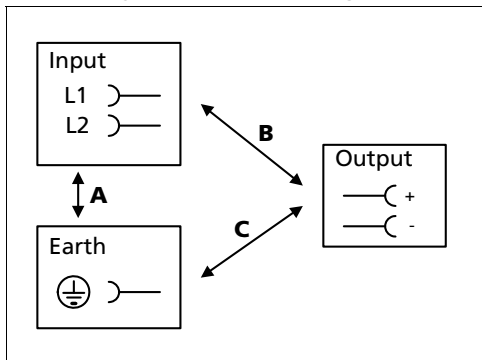
Input / output separation *)	SELV PELV	IEC/EN 60950-1 IEC/EN 60204-1, EN 50178, IEC 62103, IEC 60364-4-41
Class of protection	I	PE (Protective Earth) connection required
Isolation resistance	> 5MΩ	Input to output, 500Vdc
PE resistance	< 0.1Ω	
Touch current (leakage current)	typ. 0.14mA typ. 0.19mA < 0.18mA < 0.25mA	400Vac, 50Hz, TN mains 480Vac, 60Hz, TN mains 440Vac, 50Hz, TN mains 528Vac, 60Hz, TN mains

\*) Double or reinforced insulation

## 17. DIELECTRIC STRENGTH

The output voltage is floating and has no ohmic connection to the ground. Type and factory tests are conducted by the manufacturer. Field tests may be conducted in the field using the appropriate test equipment which applies the voltage with a slow ramp (2s up and 2s down). Connect all phase-terminals together as well as all output poles before conducting the test. When testing, set the cut-off current settings to the value in the table below.





Fig. 17-1 Dielectric strength



		<b>A</b>	<b>B</b>	<b>C</b>
Type test	60s	2500Vac	3000Vac	500Vac
Factory test	5s	2500Vac	2500Vac	500Vac
Field test	5s	2000Vac	2000Vac	500Vac
Cut-off current setting		> 5mA	> 5mA	> 15mA

To fulfill the PELV requirements according to EN60204-1 § 6.4.1, we recommend that either the + pole, the - pole or any other part of the output circuit shall be connected to the protective earth system. This helps to avoid situations in which a load starts unexpectedly or can not be switched off when unnoticed earth faults occur.

## 18. APPROVALS

IEC 60950-1		CB Scheme, Information Technology Equipment
UL 508		LISTED for use in U.S.A. (UL 508) and Canada (C22.2 No. 107-1-01) E-File: E198865 Industrial Control Equipment
UL 60950-1		RECOGNIZED for the use in U.S.A. (UL 60950-1) and Canada (C22.2 No. 60950) E-File: E137006 Information Technology Equipment, Level 3
Marine, pending		GL (Germanischer Lloyd) classified and ABS (American Bureau for Shipping) PDA Environmental category: C, EMC2 Marine and offshore applications

## 19. FULFILLED STANDARDS

EN 61558-2-17	Safety of Power Transformers
EN/IEC 60204-1	Safety of Electrical Equipment of Machines
EN/IEC 61131-2	Programmable Controllers
EN 50178, IEC 62103	Electronic Equipment in Power Installations

## 20. USED SUBSTANCES

The unit does not release any silicone and is suitable for the use in paint shops.

The unit conforms to the RoHS directive 2002/96/EC

Electrolytic capacitors included in this unit do not use electrolytes such as Quaternary Ammonium Salt Systems.

Plastic housings and other molded plastic materials are free of halogens, wires and cables are not PVC insulated.

The production material within our production does not include following toxic chemicals:

Polychlorized Biphenyl (PCB), Polychlorized Terphenyl (PCT), Pentachlorophenol (PCP), Polychlorinated naphthalene (PCN), Polybrom Biphenyl (PBB), Polybrom Biphenyl-oxyd (PBO), Polybrominated Diphenylether (PBDE), Polychlorinated Diphenylether (PCDE), Polydibromphenyl Oxyd (PBDO), Cadmium, Asbest, Mercury, Silicia

### 21. PHYSICAL DIMENSIONS AND WEIGHT

Weight	500g / 1.1lb
DIN-Rail	Use 35mm DIN-rails according to EN 60715 or EN 50022 with a height of 7.5 or 15mm. The DIN-rail height must be added to the unit depth (117mm) to calculate the total required installation depth.
Installation Clearances	See chapter 2

Fig. 21-1 **Front view**

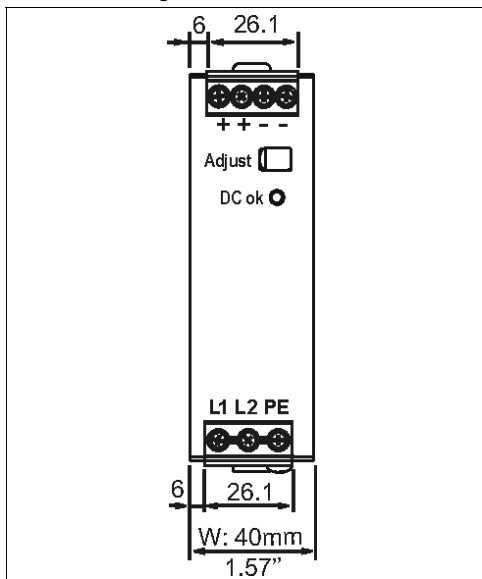
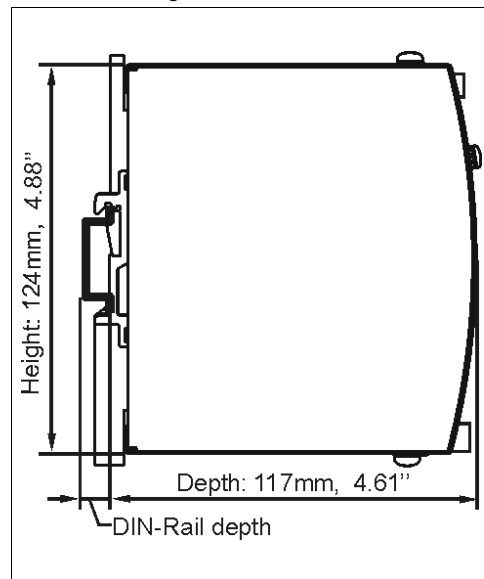


Fig. 21-2 **Side view**

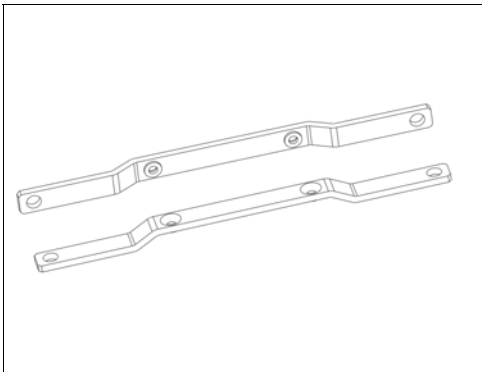


## 22. ACCESSORIES

### ZM1.WALL Wall mounting bracket

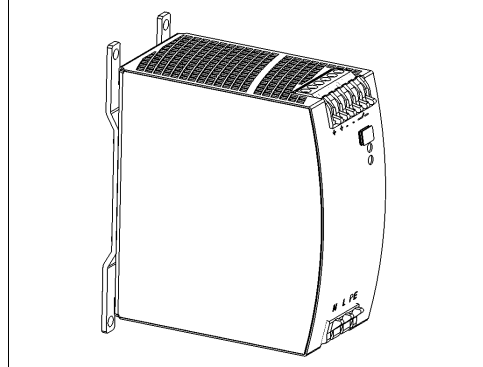
This bracket is used to mount specific Dimension units onto a flat surface without utilizing a DIN-Rail. The two aluminum brackets and the black plastic slider of the unit have to be removed, so that the two steel brackets can be mounted.

Fig. 22-1 **ZM1.WALL Wall mounting bracket**



\*) Picture of the power supply is for representation only

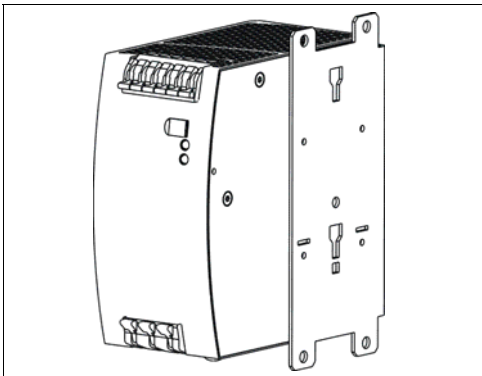
Fig. 22-2 **Assembled wall mounting bracket \*)**



### ZM12.SIDE Side mounting bracket

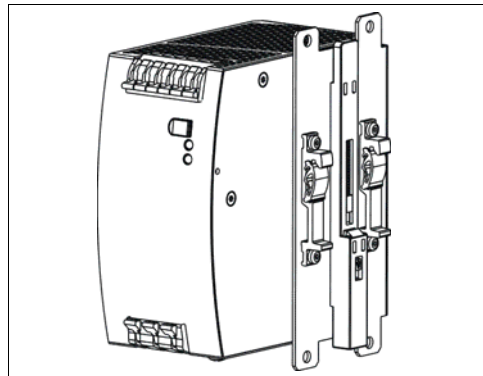
This bracket is used to mount Dimension units sideways with or without utilizing a DIN-Rail. The two aluminum brackets and the black plastic slider of the unit have to be detached, so that the steel brackets can be mounted. For sideways DIN-rail mounting, the removed aluminum brackets and the black plastic slider need to be mounted on the steel bracket.

Fig. 22-3  
**ZM13.SIDE Side mounting bracket \*)**



\*) Picture of the power supply is for representation only

Fig. 22-4  
**Side mounting with DIN-rail brackets \*)**



## 23. APPLICATION NOTES

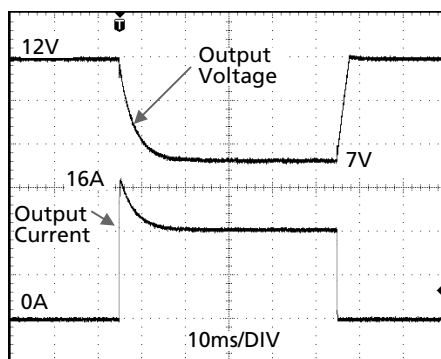
### 23.1. PEAK CURRENT CAPABILITY

Solenoids, contactors and pneumatic modules often have a steady state coil and a pick-up coil. The inrush current demand of the pick-up coil is several times higher than the steady-state current and usually exceeds the nominal output current (including the PowerBoost). The same situation applies, when starting a capacitive load.

Branch circuits are often protected with circuit breakers or fuses. In case of a short or an overload in the branch circuit, the fuse needs a certain amount of over-current to trip or to blow. The peak current capability ensures the safe operation of subsequent circuit breakers.

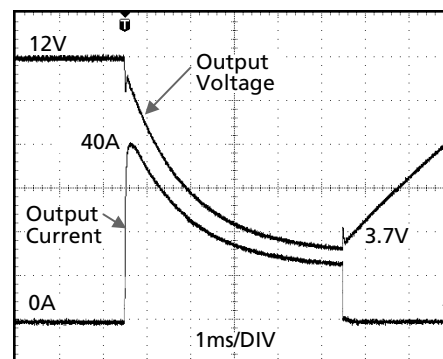
Assuming the input voltage is turned on before such an event, the built-in large sized output capacitors inside the power supply can deliver extra current. Discharging this capacitor causes a voltage dip on the output. The following two examples show typical voltage dips:

Fig. 23-1 Peak load 16A for 50ms, typ.



Peak load 16A (resistive load) for 50ms  
Output voltage dips from 12V to 7V.

Fig. 23-2 Peak load 40A for 5ms, typ.



Peak load 40A (resistive load) for 5ms  
Output voltage dips from 12V to 3.7V.

### 23.2. BACK-FEEDING LOADS

Loads such as decelerating motors and inductors can feed voltage back to the power supply. This feature is also called return voltage immunity or resistance against Back- E.M.F. (Electro Magnetic Force).

This power supply is resistant and does not show malfunctioning when a load feeds back voltage to the power supply. It does not matter, whether the power supply is on or off.

The maximum allowed feed-back-voltage is 25Vdc. The absorbing energy can be calculated according to the built-in large sized output capacitance which is specified in chapter 6.

### 23.3. CHARGING OF BATTERIES

The power supply can be used to charge 12V lead-acid or maintenance free batteries.

**Instructions for charging batteries:**

- a) Ensure that the ambient temperature of the power supply is below 45°C
- b) Set output voltage (measured at no load and at the battery end of the cable) very precisely to the end-of-charge voltage.

End-of-charge voltage	13.9V	13.75V	13.6V	13.4V
Battery temperature	10°C	20°C	30°C	40°C

- c) Use a 10A circuit breaker (or blocking diode) between the power supply and the battery.
- d) Ensure that the output current of the power supply is below the allowed charging current of the battery.
- e) The return current to the power supply (battery discharge current) is typ. 5.5mA when the power supply is switched off (except in case a blocking diode is utilized).

### 23.4. EXTERNAL INPUT PROTECTION

The unit is tested and approved for branch circuits up to 30A (U.S.A.) and 32A (IEC). An external protection is only required, if the supplying branch has an ampacity greater than this. Check also local codes and local requirements. In some countries local regulations might apply.

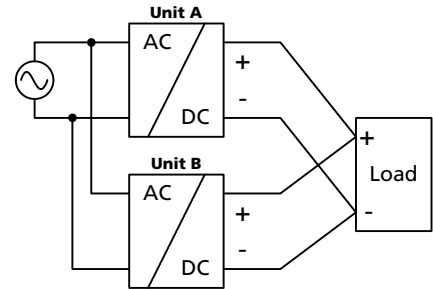
If an external fuse is necessary or utilized, minimum requirements need to be considered to avoid nuisance tripping of the circuit breaker. A minimum value of 6A B- or 3A C-Characteristic breaker should be used

### 23.5. INDUCTIVE AND CAPACITIVE LOADS

The unit is designed to supply any kind of loads, including unlimited capacitive and inductive loads.

### 23.6. PARALLEL USE TO INCREASE OUTPUT POWER

CT5.121 power supplies can be paralleled to increase the output power. This power supply has no feature included which balances the load current between the power supplies. Usually the power supply with the higher adjusted output voltage draws current until it goes into current limitation. Therefore, the power supply can only be used in parallel as long as the ambient temperature stays below 45°C. The output voltages of all power supplies shall be adjusted to the same value ( $\pm 100\text{mV}$ ). A fuse or diode on the output of each unit is only required if more than three units are connected in parallel. If a fuse (or circuit breaker) is used, choose one with approximately 150% of the rated output current of one power supply. Keep an installation clearance of 15mm (left / right) between two power supplies and avoid installing the power supplies on top of each other. Do not use power supplies in parallel in mounting orientations other than the standard mounting orientation (input terminals on the bottom and output terminals on top of the unit). Pay attention that leakage current, EMI, inrush current, harmonics will increase when using multiple power supplies.



### 23.7. PARALLEL USE FOR REDUNDANCY

Power supplies can be paralleled for redundancy to gain higher system availability. Redundant systems require a certain amount of extra power to support the load in case one power supply unit fails. The simplest way is to put two power supplies in parallel. This is called a 1+1 redundancy. In case one power supply unit fails, the other one is automatically able to support the load current without any interruption. Redundant systems for a higher power demand are usually built in a N+1 method. E.g. six power supplies, each rated for 8A are paralleled to build a 40A redundant system.

**Please note:** This simple way to build a redundant system does not cover failures such as an internal short circuit in the secondary side of the power supply. In such a case, the defect unit becomes a load for the other power supplies and the output voltage can not be maintained any more. This can only be avoided by utilizing decoupling diodes which are included in the decoupling module YR2.DIODE.

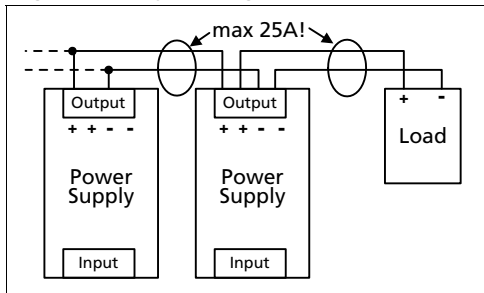
Recommendations for building redundant power systems:

- Use separate input fuses for each power supply.
- Monitor the individual power supply units.
- 1+1 Redundancy is allowed up to an ambient temperature of 60°C  
N+1 Redundancy is allowed up to an ambient temperature of 45°C
- It is desirable to set the output voltages of all units to the same value ( $\pm 100\text{mV}$ ) or leave it at the factory setting.

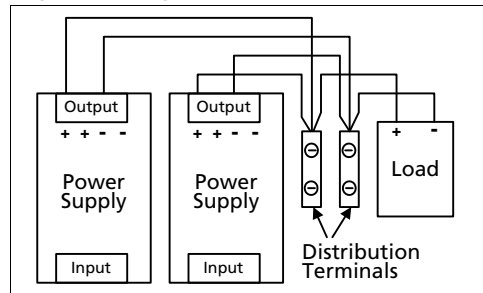
### 23.8. DAISY CHAINING OF OUTPUTS

Daisy chaining (jumping from one power supply output to the next) is allowed as long as the average output current through one terminal pin does not exceed 25A. If the current is higher, use a separate distribution terminal block.

**Fig. 23-3 Daisy chaining of outputs**

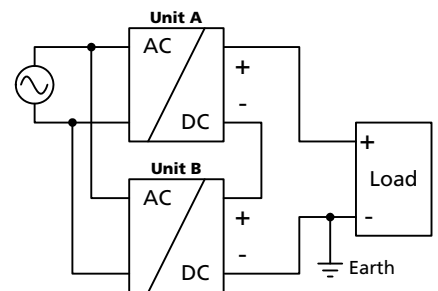


**Fig. 23-4 Using distribution terminals**



### 23.9. SERIES OPERATION

Power supplies of the same type can be connected in series for higher output voltages. It is possible to connect as many units in series as needed, providing the sum of the output voltage does not exceed 150Vdc. Voltages with a potential above 60Vdc are not SELV any more and can be dangerous. Such voltages must be installed with a protection against touching. Earthing of the output is required when the sum of the output voltage is above 60Vdc. Avoid return voltage (e.g. from a decelerating motor or battery) which is applied to the output terminals. Keep an installation clearance of 15mm (left / right) between two power supplies and avoid installing the power supplies on top of each other. Do not use power supplies in series in mounting orientations other than the standard mounting orientation (input terminals on the bottom and output terminals on top of the unit). Pay attention that leakage current, EMI, inrush current, harmonics will increase when using multiple power supplies.



### 23.10. USE IN A TIGHTLY SEALED ENCLOSURE

When the power supply is installed in a tightly sealed enclosure, the temperature inside the enclosure will be higher than outside. In such situations, the inside temperature defines the ambient temperature for the power supply.

The following measurement results can be used as a reference to estimate the temperature rise inside the enclosure.

The power supply is placed in the middle of the box, no other heat producing items are inside the box

Enclosure:	Rittal Typ IP66 Box PK 9516 100, plastic, 110x180x165mm
Load:	12V, 6.4A; (=80%) load is placed outside the box
Input:	2x 400Vac
Temperature inside enclosure:	51.1°C (in the middle of the right side of the power supply with a distance of 2cm)
Temperature outside enclosure:	25.2°C
Temperature rise:	25.9K

## 23.11. MOUNTING ORIENTATIONS

Mounting orientations other than input terminals on the bottom and output on the top require a reduction in continuous output power or a limitation in the maximal allowed ambient temperature. The amount of reduction influences the lifetime expectancy of the power supply. Therefore, two different derating curves for continuous operation can be found below:

**Curve A1** Recommended output current.

**Curve A2** Max allowed output current (results in approximately half the lifetime expectancy of A1).

Fig. 23-5  
**Mounting Orientation A**  
(Standard orientation)

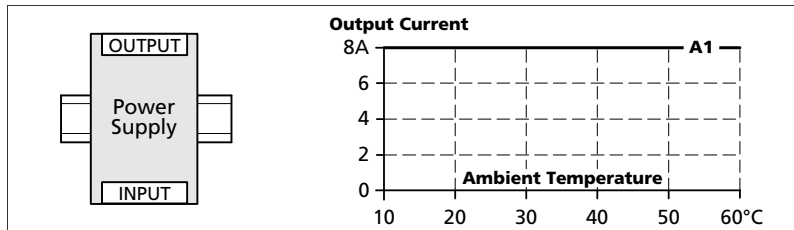


Fig. 23-6  
**Mounting Orientation B**  
(Upside down)

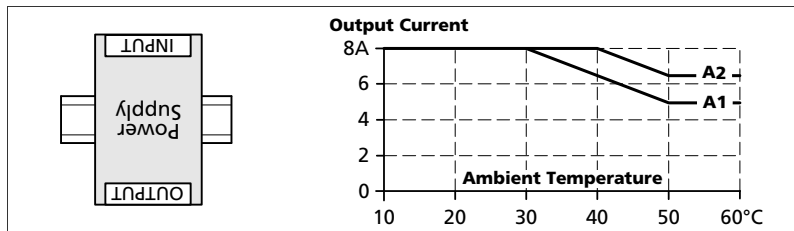


Fig. 23-7  
**Mounting Orientation C**  
(Table-top mounting)

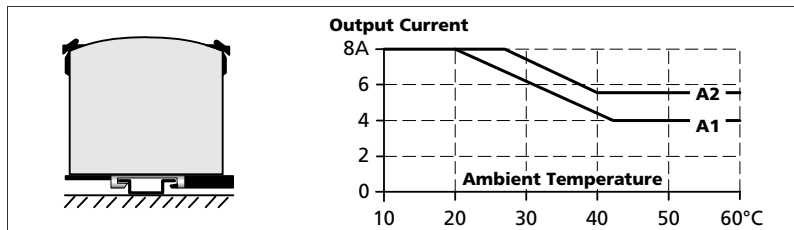


Fig. 23-8  
**Mounting Orientation D**  
(Horizontal cw)

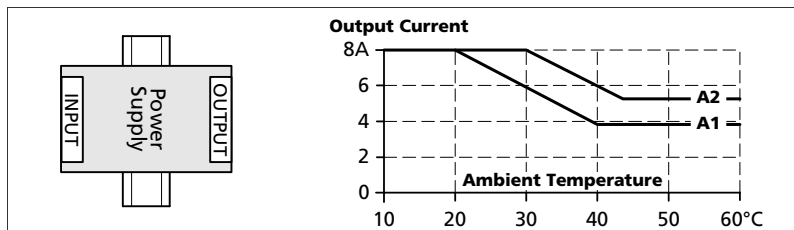


Fig. 23-9  
**Mounting Orientation E**  
(Horizontal ccw)

