



REDUNDANCY MODULE

- For N+1 and 1+1 Redundant Systems
- Dual Input with Single Output
- Minimal Losses - Mosfets Instead of Diodes
- Only 72mV Voltage Drop at 20A Output Current
- Only 2.15W Loss at 20A and 6.3W at 40A Output Current
- 160% (65A) Peak Load Capability
- Reverse Polarity Protected Input
- Full Power Between -40°C and +70°C
- Width only 36mm
- Rugged Metal Housing
- Easy Wiring:
Distribution Terminal for Negative Pole Included
- 3 Year Warranty

GENERAL DESCRIPTION

The YR40.241 is a redundancy module, which can be used to build 1+1 and N+1 redundant systems. It is equipped with two input channels which can be connected to 20A power supplies and one output which can carry nominal currents up to 40A.

The novelty of this redundancy module is the utilization of mosfets instead of diodes for the decoupling of the two input channels. This reduces the heat generation and the voltage drop between input and output. The redundancy module does not require an additional auxiliary voltage and is self-sufficient even in case of a short circuit across the output.

Due to the low power losses, the unit is very slender and only requires 36mm width on the DIN-rail. Large connection terminals allow for a safe and fast installation with a large international approval package. This unit is suitable for nearly every application.

SHORT-FORM DATA

Input voltage	DC 24-28V	±30%
Input voltage range	16.8–36.4Vdc	
Input current	2x 0–20A 2x 20–32.5A	continuous for 5 seconds
Output current	0–40A 40–65A 65A	continuous for 5 seconds at cont. overload/ short circuit
Input to output voltage drop	typ. 72mV typ. 112mV typ. 140mV	input: 2x10A input: 1x20A input: 2x20A
Power losses	typ. 700mW typ. 2.15W typ. 2.65W typ. 6.3W	at no load input: 2x10A input: 1x20A input: 2x20A
Temperature range	-40°C to +70°C	operational, no de-rating req.
Dimensions	36x124x127mm*)	WxHxD

*) plus 4mm in depth for the screw terminal

ORDER NUMBERS

Redundancy Module	YR40.241	24-28V Standard unit
Accessory	ZM1.WALL	Wall/panel mount bracket
	ZM2.WALL	Wall/panel mount bracket
	ZM11.SIDE	Side mount bracket

MARKINGS



INDEX

	Page		Page
1. Intended Use	3	14. Approvals	11
2. Installation Requirements	3	15. Fulfilled Standards	11
3. Input and Output Characteristics	4	16. Used Substances	11
4. Power Losses	5	17. Physical Dimensions and Weight	12
5. Reliability	6	18. Accessories	13
6. Terminals and Wiring	6	19. Application Notes	15
7. Functional Diagram	7	19.1. Recommendations for Redundancy	15
8. Front Side and User Elements	7	19.2. Inductive and Capacitive Loads	15
9. EMC	8	19.3. Sideways Installation Clearances	15
10. Environment	9	19.4. 1+1 Redundancy up to 20A	16
11. Protection Features	10	19.5. N+1 Redundancy, Example with 60A	16
12. Safety Features	10	19.6. Mounting Orientations	17
13. Dielectric Strength	10		

The information presented in this document is believed to be accurate and reliable and may change without notice. No part of this document may be reproduced or utilized in any form without permission in writing from the publisher.

TERMINOLOGY AND ABBREVIATIONS

PE and \oplus symbol	PE is the abbreviation for Protective Earth and has the same meaning as the symbol \oplus .
Earth, Ground	This document uses the term "earth" which is the same as the U.S. term "ground".
T.b.d.	To be defined, value or description will follow later.
DC 24V	A figure displayed with the AC or DC before the value represents a nominal voltage with standard tolerances (usually $\pm 15\%$) included. E.g.: DC 12V describes a 12V battery disregarding whether it is full (13.7V) or flat (10V)
24Vdc	A figure with the unit (Vdc) at the end is a momentary figure without any additional tolerances included.
may	A key word indicating flexibility of choice with no implied preference
shall	A key word indicating a mandatory requirement
should	A key word indicating flexibility of choice with a strongly preferred implementation
1+1 Redundancy	Use of two identical power supplies in parallel to provide continued operation following most failures in a single power supply. The two power supply outputs should be isolated each other by utilizing diodes or other switching arrangements. E.g. two 10A power supplies are needed to achieve a 10A redundant system.
N+1 Redundancy	Use of three or more identical power supplies in parallel to provide continued operation following most failures in a single power supply. All power supply outputs should be isolated each other by utilizing diodes or other switching arrangements. E.g.: To achieve a 40A redundant system, five 10A power supplies are needed in a N+1 redundant system.

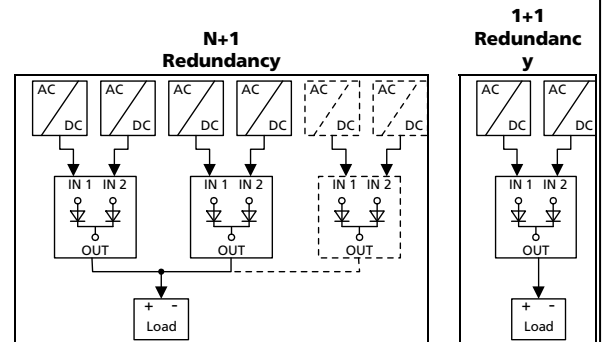

1. INTENDED USE

This device is designed for installation in an enclosure (according to the requirements of the end-standard) and is intended for the general use such as in industrial control, office, communication, and instrumentation equipment.

Do not use this power supply in aircraft, trains and nuclear equipment where malfunction may cause severe personal injury or threaten human life.

2. INSTALLATION REQUIREMENTS

This device may only be installed and put into operation by qualified personnel.

This device does not contain serviceable parts.

If damage or malfunction should occur during installation or operation, immediately turn power off and send unit to the factory for inspection.

Mount the unit on a DIN-rail so that the input terminals are located on the top and the output terminals on the bottom of the unit. For other mounting orientations see de-rating requirements of chapter 19.6. in this document.

This device is designed for convection cooling and does not require an external fan. Do not obstruct airflow and do not cover the ventilation grid (e.g. cable conduits) by more than 30%!

Keep the following installation clearances:

40mm on top,

20mm on the bottom,

5mm on the left and right sides are recommended when the device is loaded permanently with more than 50% of the rated output current. Increase the side clearance to 15mm in case the adjacent device is a heat source (e.g. another power supply).

See also chapter 19.3 for further information in combination with QS20 and QT20 power supplies from the PULS DIMENSION series.



WARNING

Risk of electrical shock, fire, personal injury or death.

- Turn power off before working on the device. Protect against inadvertent re-powering.
- Make sure that the wiring is correct by following all local and national codes.
- Do not open, modify or repair the unit.
- Use caution to prevent any foreign objects from entering the housing.
- Do not use in wet locations or in areas where moisture or condensation can be expected.
- Do not touch during power-on, and immediately after power-off. Hot surfaces may cause burns.

3. INPUT AND OUTPUT CHARACTERISTICS

Number of inputs	-	2	
Number of outputs	-	1	
Input voltage	nom.	DC 24-28V	±30% The input circuitry must meet the SELV requirements stipulated by IEC/EN/UL 60950-1.
Input voltage range	-	16.8–36.4Vdc	
Voltage drop, input to output	typ.	140mV	at 2x20A, see Fig. 3-1
	typ.	72mV	at 2x10A, see Fig. 3-1
	typ.	112mV	at 1x20A, see Fig. 3-2
Input current	nom.	2x 0–20A	continuous
	nom.	2x 20–32.5A	for 5 seconds
	max.	2x 32.5A	at continuous overload or short circuit
Peak input current	max.	1000A	for max. 1ms per input
Output current	nom.	40A	continuous
	nom.	40–65A	for 5 seconds
	max.	65A	at continuous overload or short circuit
Reverse current	max.	1mA	at 24V, per input, -40°C to +70°C
Reverse voltage	max.	40Vdc	voltage applied to the output, continuously allowed
Output capacitance	typ.	320µF	

Note: Ensure that the continuous output current does not exceed 65A. Check the short-circuit current of the power sources and if the power source can deliver more than 65A together, use an appropriate fuse on the output.

Fig. 3-1 Input to output voltage drop when both inputs draw current
(typical 1+1 redundant case, when the output voltages of the two units are equal)

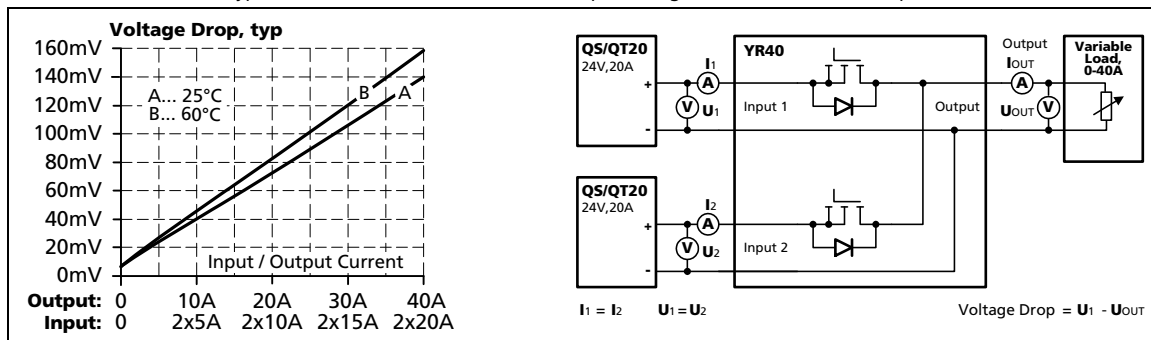
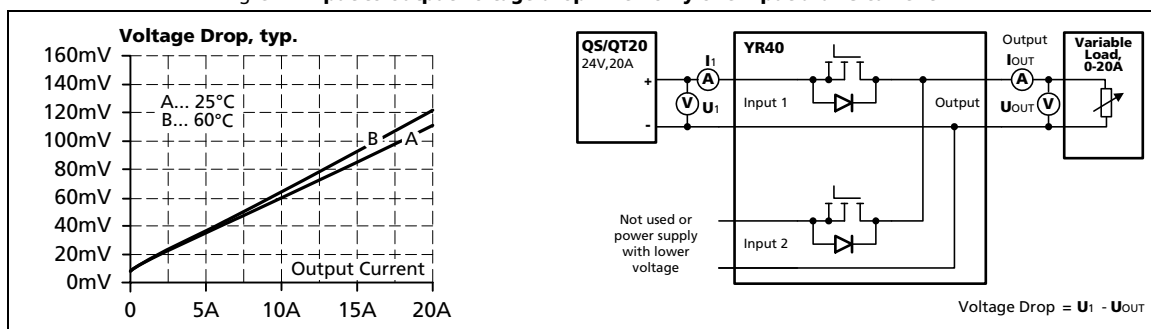

Fig. 3-2 Input to output voltage drop when only one input draws current



4. POWER LOSSES

DC 24V			
Power losses	typ.	2.15W	input: 2x10A
	typ.	6.3W	input: 2x20A
	typ.	2.6W	input: 1x20A, (only one input is connected to input voltage)
Standby power losses	typ.	0.35W	at no output current, (only one input is connected to input voltage)
	typ.	0.7W	at no output current, (both inputs are connected to input voltages)

Fig. 4-1 Power losses when both inputs draw equal current

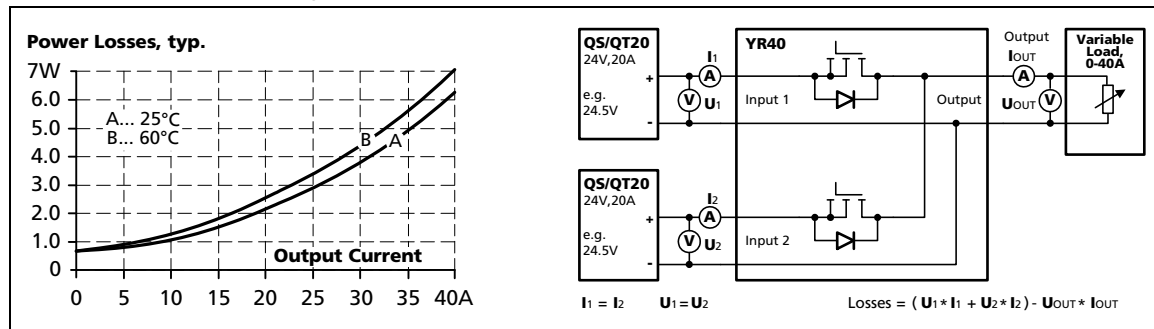
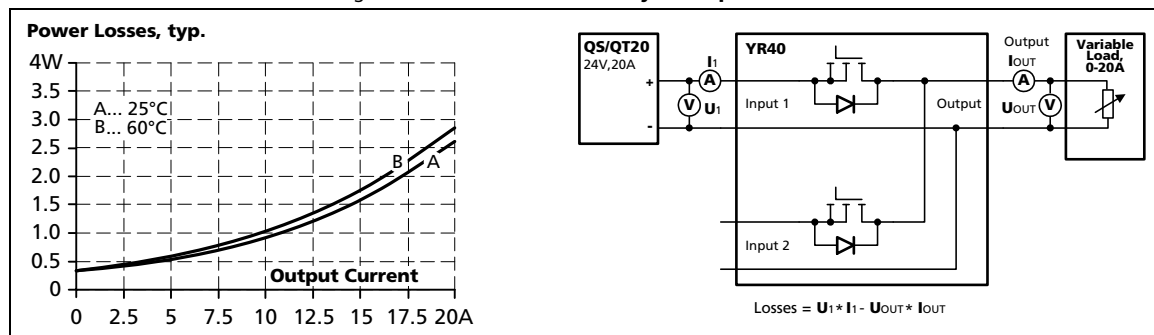

Fig. 4-2 Power losses when only one input is used



Note: As soon as voltage is applied on input 2, an additional 0.35W will be consumed. It is not relevant, whether this channel contributes to the output current or not.

5. RELIABILITY

Input / output current conditions	Input: 2x10A Output: 20A	Input: 2x20A Output: 40A	Input: 1x20A Output: 20A	
Lifetime expectancy *)	T.B.D.	T.B.D.	T.B.D.	at 24V and 40°C
	T.B.D.	T.B.D.	T.B.D.	at 24V and 40°C
	T.B.D.	T.B.D.	T.B.D.	at 24V and 25°C
MTBF **) SN 29500, IEC 61709	T.B.D.	T.B.D.	T.B.D.	at 24V 40°C
	T.B.D.	T.B.D.	T.B.D.	at 24V 25°C
MTBF **) MIL HDBK 217F	T.B.D.	T.B.D.	T.B.D.	Ground Benign GB40 (24V and 40°C)
	T.B.D.	T.B.D.	T.B.D.	Ground Benign GB25 (24V and 25°C)

*) The **Lifetime expectancy** shown in the table indicates the minimum operating hours (service life) and is determined by the lifetime expectancy of the built-in electrolytic capacitors. Lifetime expectancy is specified in operational hours and is calculated according to the capacitor's manufacturer specification. The prediction model allows only a calculation of up to 15 years from date of shipment.

) **MTBF stands for **Mean Time Between Failure**, which is calculated according to statistical device failures, and indicates reliability of a device. It is the statistical representation of the likelihood of a unit to fail and does not necessarily represent the life of a product.

6. TERMINALS AND WIRING

	Input	Output
Type	screw termination	screw termination
Solid wire	0.5-6mm ²	0.5-16mm ²
Stranded wire	0.5-4mm ²	0.5-10mm ²
American Wire Gauge	20-10 AWG	22-8 AWG
Wire stripping length	7mm / 0.275inch	12mm / 0.5inch
Screwdriver	3.5mm slotted or Pozidrive No 2	3.5mm slotted or Pozidrive No 2
Recommended tightening torque	0.8Nm, 7lb.in	1.2Nm, 10.6lb.in

To connect the chassis, use a ring-type terminal (ring cable lug) which is suitable for a M4 screw and connect it to the chassis ground terminal on top of the unit.

Instructions:

- The external circuitry of all terminals must meet the safety requirements stipulated by IEC/EN/UL 60950-1: SELV.
- Use appropriate copper cables that are designed for minimum operating temperatures of:
 - 60°C for ambient up to 45°C and
 - 75°C for ambient up to 60°C and
 - 90°C for ambient up to 70°C minimum.
- Follow national installation codes and installation regulations!
- Ensure that all strands of a stranded wire enter the terminal connection!
- Up to two stranded wires with the same cross section are permitted in one connection point.
- Screws of unused terminal compartments should be securely tightened.
- Ferrules are allowed, but not required.
- Do not connect or disconnect the wires from the terminals below -25°C (-13°F).

7. FUNCTIONAL DIAGRAM

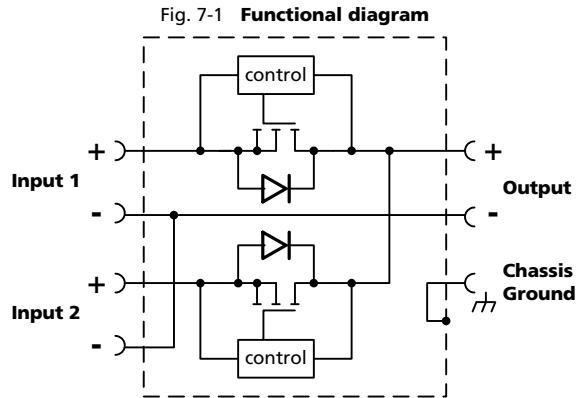

8. FRONT SIDE AND USER ELEMENTS

Fig. 8-1 Front side



A Output Terminals (screw terminals)

B Chassis Ground Terminals

To be connected on the top side of the housing with a ring-type terminal (ring cable lug) which is suitable for a M4 screw. Connection of the chassis is optional and not required since the unit fulfils the requirements according to protection class III.

C Input Terminals for Input 1 (screw terminals)

D Input Terminals for Input 2 (screw terminals)

9. EMC

The redundancy module YR40.241 is suitable for applications in industrial environment as well as in residential, commercial and light industry environment without any restrictions (e.g. cable length). The CE mark indicates conformance with EMC guideline 2004/108/EC and the low-voltage directive (LVD) 2006/95/EC. A detailed EMC report is available on request.

EMC Immunity	According generic standards: EN 61000-6-1 and EN 61000-6-2			
Electrostatic discharge	EN 61000-4-2	Contact discharge	8kV	Criterion A
		Air discharge	15kV	Criterion A
Electromagnetic RF field	EN 61000-4-3	80MHz-2.7GHz	10V/m	Criterion A
Fast transients (Burst)	EN 61000-4-4	Input lines	2kV	Criterion A
		Output lines	2kV	Criterion A
Surge voltage on input lines	EN 61000-4-5	+ → -	500V	Criterion A
		+/- → Chassis ground	1kV	Criterion A
Surge voltage on output lines	EN 61000-4-5	+ → -	500V	Criterion A
		+/- → Chassis ground	1kV	Criterion A
Conducted disturbance	EN 61000-4-6	0.15-80MHz	10V	Criterion A
Power-frequency magnetic field *)	EN 61000-4-8	50Hz	30A/m	Criterion A

Criteria:

A: Redundancy module shows normal operation behavior within the defined limits.

Notes:

*) A test is not applicable according to EN 50082-2, since the device does not contain components susceptible to magnetic fields, e.g. hall elements, electrodynamic microphones, etc.

EMC Emission	According generic standards: EN 61000-6-3 and EN 61000-6-4	
Conducted emission	IEC/CISPR 16-1-2, IEC/CISPR 16-2-1	Class B, input lines *)
	IEC/CISPR 16-1-2, IEC/CISPR 16-2-1	Class B, output lines *)
Radiated emission	EN 55011, EN 55022	Class B

This device complies with FCC Part 15 rules.

Operation is subjected to following two conditions: (1) this device may not cause harmful interference, and (2) this device must accept any interference received, including interference that may cause undesired operation.

*) Provided, that power sources connected on the inputs fulfill the class B requirements too.

Switching frequency The internal auxiliary supply is generated with a boost converter.
The switching frequency is typ. 16kHz.

10. ENVIRONMENT

Operational temperature *)	-40°C to +70°C (-40°F to 158°F)	
Storage temperature	-40 to +85°C (-40°F to 185°F)	for storage and transportation
Humidity **)	5 to 95% r.H.	IEC 60068-2-30
Vibration sinusoidal	2-17.8Hz: ±1.6mm; 17.8-500Hz: 1g 2 hours / axis	IEC 60068-2-6
Shock	30g 6ms, 20g 11ms 3 bumps / direction, 18 bumps in total	IEC 60068-2-27
Altitude	0 to 2000m (0 to 6 560ft) 2000 to 6000m (6 560 to 20 000ft)	without any restrictions reduce output power or ambient temperature, see Fig. 10-2
Altitude de-rating	2.5A/1000m or 5°C/1000m	> 2000m (6500ft), see Fig. 10-2
Over-voltage category	not applicable	The concept of the overvoltage category is used for equipment energized directly from the low voltage mains (IEC 60664-1 §4.3.3.2.1).
Degree of pollution	2	IEC 62103, EN 50178, not conductive

*) Operational temperature is the same as the ambient temperature and is defined as the air temperature 2cm below the unit.

***) Do not energize while condensation is present

Fig. 10-1 Output current vs. ambient temp.

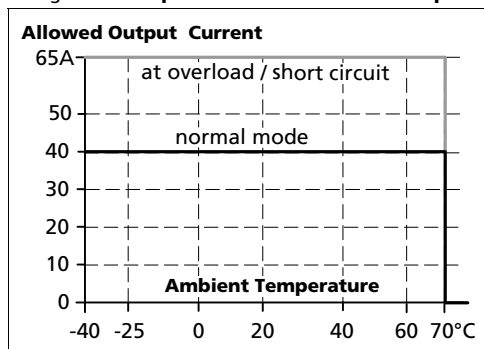
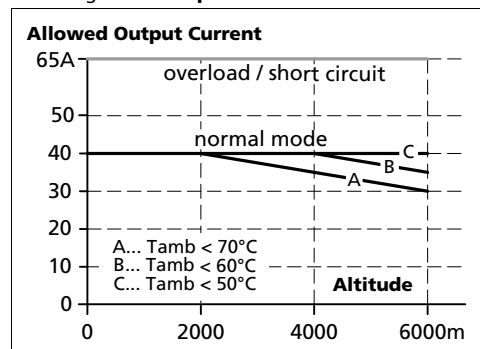

Fig. 10-2 Output current vs. altitude



11. PROTECTION FEATURES

Output over-current protection	not included	
Reverse input polarity protection	included	unit does not start when input voltage is reversed
Degree of protection	IP 20	EN/IEC 60529
Penetration protection	> 3.6mm	e.g. screws, small parts
Over-temperature protection	not included	
Input transient protection	not included	
Output transient protection	included	see EMC section
Internal input fuse	not included	

12. SAFETY FEATURES

Input / output separation	no galvanic separation	Mosfet between input and output
Class of protection	III	PE (Protective Earth) or chassis connection not required
PE resistance	< 0.10hm	between housing and chassis-ground terminal

13. DIELECTRIC STRENGTH

The input and output voltages have the same reference, are floating and have no ohmic connection to ground. Type and factory tests are conducted by the manufacturer. Field tests may be conducted in the field using the appropriate test equipment which applies the voltage with a slow ramp (2s up and 2s down). Connect input/output terminals together before conducting the test.

When testing, set the cut-off current settings to the value in the table below.

Fig. 13-1 Dielectric strength

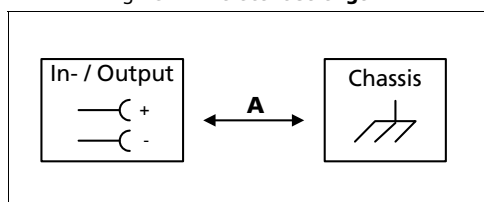

		A
Type test	60s	500Vac
Factory test	5s	500Vac
Field test	5s	500Vac
Cut-off current setting		> 2mA

14. APPROVALS

IEC 60950-1,
pending



CB Scheme,
Information Technology Equipment

UL 508,
pending



Listed for use as Industrial Control Equipment;
U.S.A. (UL 508) and Canada (C22.2 No. 107-1-01);
E-File: E198865

UL 60950-1,
pending



Recognized for use as Information Technology Equipment,
Level 5; U.S.A. (UL 60950-1) and Canada (C22.2 No. 60950);
E-File: E137006

ANSI / ISA 12.12.01-2007
(Class I Div 2),
pending



LISTED for use in Hazardous Location Class I Div 2 Tx Groups
A,B,C,D systems; U.S.A. (ANSI / ISA 12.12.01-2007) and Canada
(C22.2 No. 213-M1987)

The unit is suitable for use in Class I Division 2 Groups A, B, C, D locations.
Substitution of components may impair suitability for Class I Division 2 environment.
Do not disconnect equipment unless power has been switched off. Wiring must be
in accordance with Class I, Division 2 wiring methods of the National Electrical Code,
NFPA 70, and in accordance with other local or national codes.

EN 60079-15
ATEX
pending



Approval for use in hazardous locations Zone 2 Category 3G.
Number of ATEX certificate: EPS 09 ATEX 1 236
The redundancy module must be built-in in an IP54 enclosure.

Marine,
pending



GL (Germanischer Lloyd) classified and
ABS (American Bureau for Shipping) PDA
Environmental category: C, EMC2
Marine and offshore applications

15. FULFILLED STANDARDS

EN/IEC 60204-1	Safety of Electrical Equipment of Machines
EN/IEC 61131-2	Programmable Controllers
EN 50178, IEC 62103	Electronic Equipment in Power Installations

16. USED SUBSTANCES

The unit does not release any silicone and is suitable for use in paint shops.

The unit conforms to the RoHS directive 2002/96/EC

Electrolytic capacitors included in this unit do not use electrolytes such as Quaternary Ammonium Salt Systems.

Plastic housings and other molded plastic materials are free of halogens, wires and cables are not PVC insulated.

The production material within our production does not include following toxic chemicals:

Polychlorized Biphenyl (PCB), Polychlorized Terphenyl (PCT), Pentachlorophenol (PCP), Polychlorinated naphthalene (PCN), Polybrom Biphenyl (PBB), Polybrom Biphenyl-oxyl (PBO), polybrominated Diphenylether (PBDE), Polychlorinated Diphenylether (PCDE), Polydibromophenyl Oxyl (PBDO), Cadmium, Asbestos, Mercury, Silicia

17. PHYSICAL DIMENSIONS AND WEIGHT

Weight	340g / 0.75lb
DIN-Rail	Use 35mm DIN-rails according to EN 60715 or EN 50022 with a height of 7.5 or 15mm. The DIN-rail height must be added to the unit depth (127mm) to calculate the total required installation depth.
Installation clearances	See chapter 2

Fig. 17-1 Front view

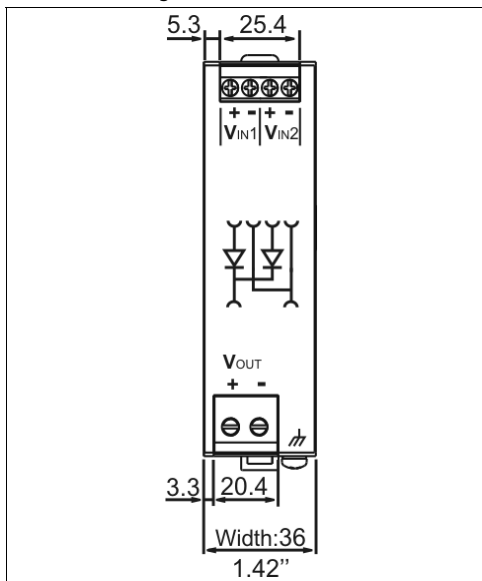
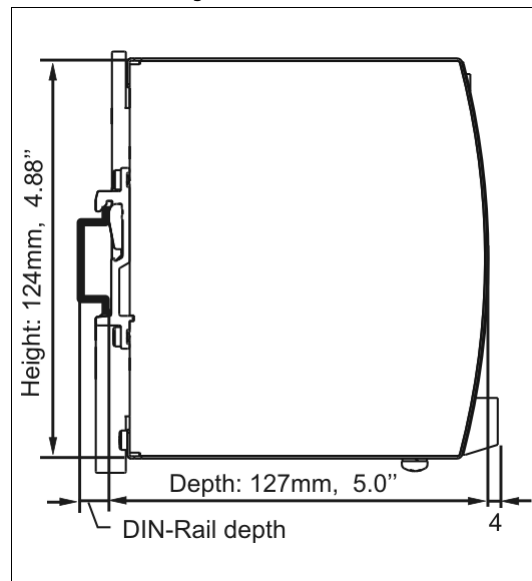

Fig. 17-2 Side view



18. ACCESSORIES

ZM1.WALL Wall mounting bracket

This standard bracket is used to mount the YR40 redundancy module onto a flat surface without utilizing a DIN-Rail.

Fig. 18-1 ZM1.WALL Wall mounting bracket

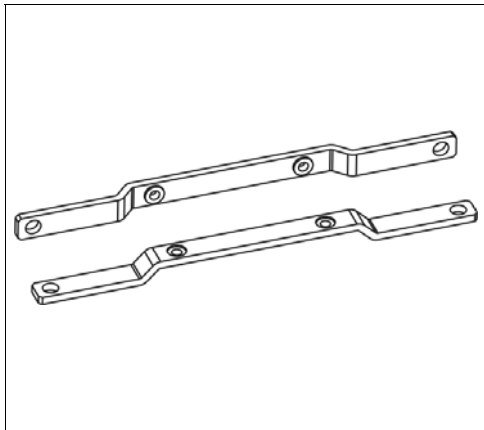
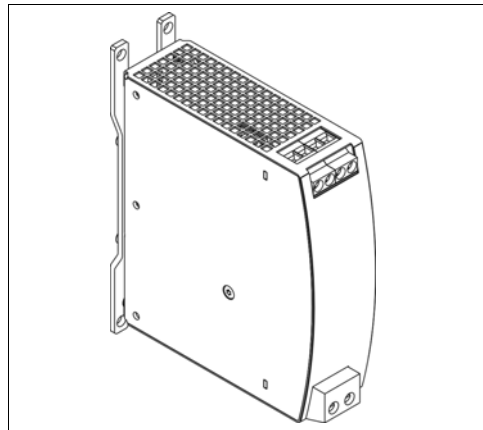

Fig. 18-2 Assembled wall mounting bracket



ZM2.WALL Wall mounting bracket

This standard bracket is used to mount the YR40 redundancy module onto a flat surface without utilizing a DIN-Rail. It is more rugged than the ZM1.WALL and allows higher mechanical vibration and shock loads.

Fig. 18-3 ZM2.WALL Wall mounting bracket

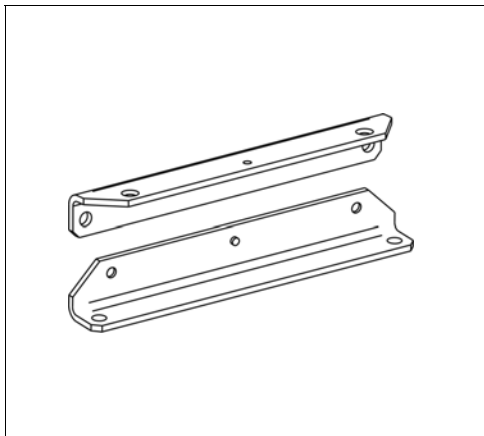
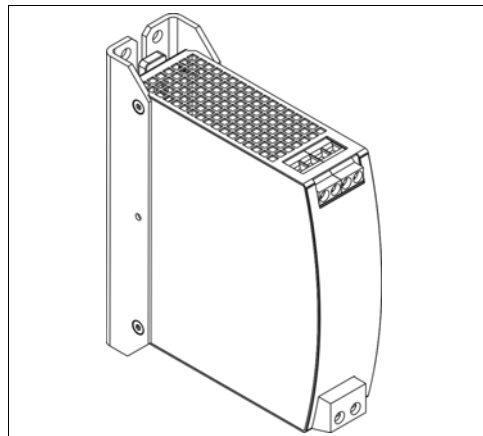

Fig. 18-4 Assembled wall mounting bracket



ZM12.SIDE Side mounting bracket

This bracket is used to mount the YR40 redundancy module sideways with or without utilizing a DIN-Rail.

The two aluminum brackets and the black plastic slider of the unit have to be detached, so that the steel brackets can be mounted.

For sideways DIN-rail mounting, the removed aluminum brackets and the black plastic slider need to be mounted on the steel bracket.

Fig. 18-5

ZM12.SIDE Side mounting bracket

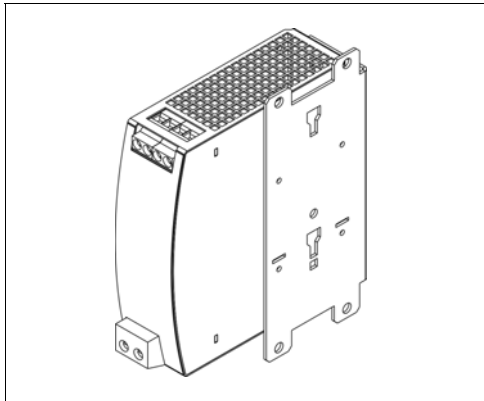
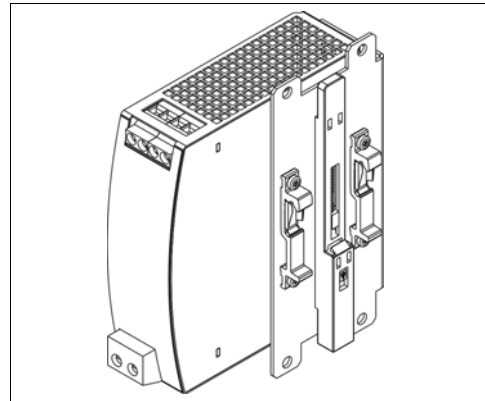

Fig. 18-6

Side mounting with DIN-rail brackets



19. APPLICATION NOTES

19.1. RECOMMENDATIONS FOR REDUNDANCY

Recommendations for the configuration of redundant power systems:

- Use separate input fuses for each power supply.
- Use three-phase power supplies to gain functional safety if one phase fails.
- When single-phase power supplies are utilized connect them to different phases or mains circuits if possible.
- Set the power supply in "Parallel-Use" mode if this feature is available
- It is desirable to set the output voltages of all power supplies to the same value.

19.2. INDUCTIVE AND CAPACITIVE LOADS

The unit is designed to supply any kind of loads, including unlimited capacitive and inductive loads.

19.3. SIDEWARDS INSTALLATION CLEARANCES

The minimum clearance recommendations are defined in chapter 2.

Normally, the following installation clearance are recommended: 40mm on top, 20mm on the bottom, 5mm on the left and right sides when the device is loaded permanently with more than 50% of the rated power. Increase this clearance to 15mm in case the adjacent device is a heat source (e.g. another power supply).

The clearance between the power supplies and the redundancy module can be reduced to zero under the following conditions:

- 1+1 redundancy application with maximum 20A output current.
- The redundancy module is placed between the two power supplies.
- The output voltage is set to the same level on both power supplies.

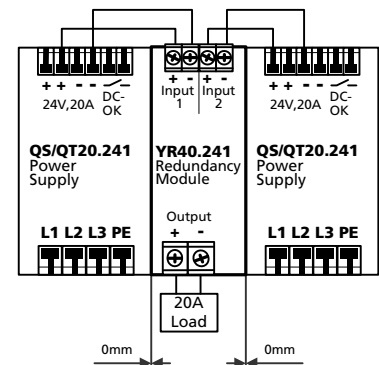

19.4. 1+1 REDUNDANCY UP TO 20A

1+1 Redundancy up to 20A requires two 20A power supplies and one YR40.241 redundancy module.

Fig. 19-1 **Wiring diagram, 1+1 Redundancy, 20A output current**

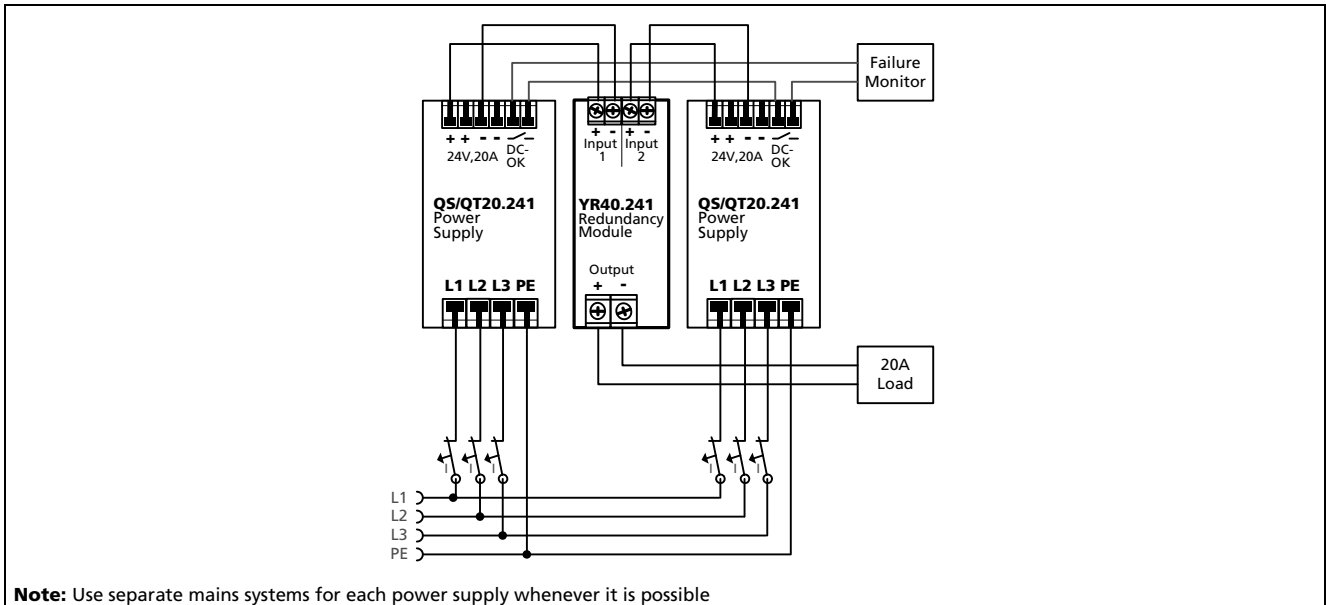

19.5. N+1 REDUNDANCY, EXAMPLE WITH 60A

N+1 Redundancy up to 60A requires four 20A power supplies and two YR40.241 redundancy modules.

Fig. 19-2 **Wiring diagram, n+1 Redundancy, 60A output current**

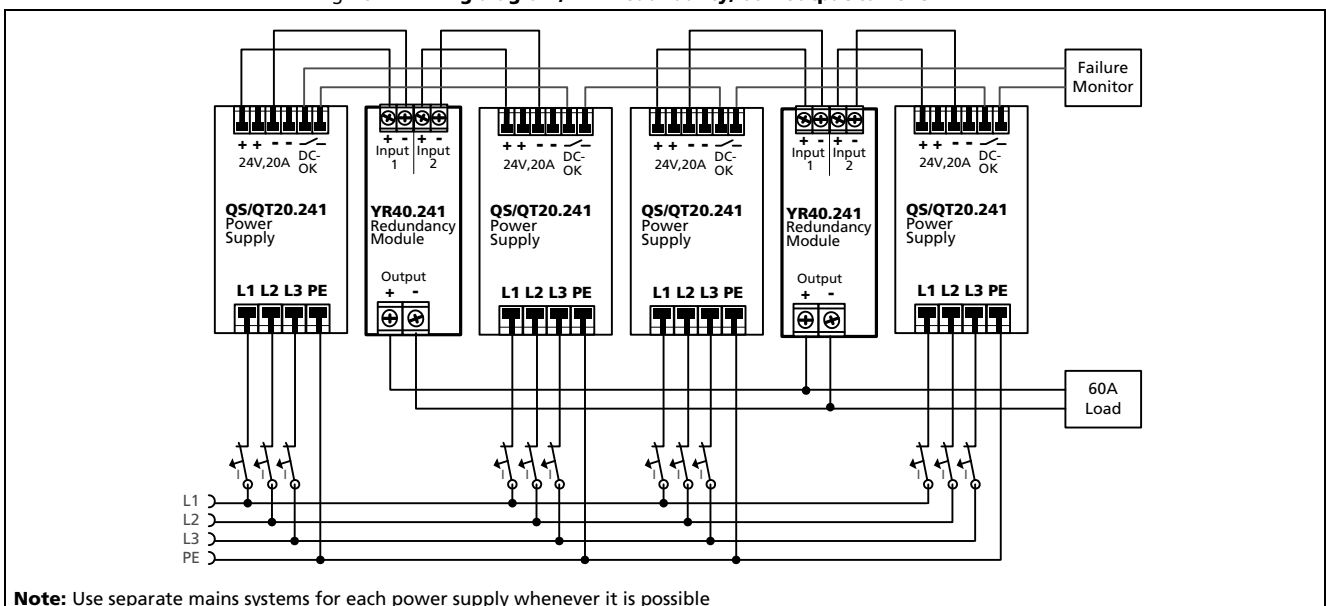

19.6. MOUNTING ORIENTATIONS

Mounting orientations other than input terminals on the bottom and output on the top require a reduction in continuous output power or a limitation in the maximum allowed ambient temperature. The amount of reduction influences the lifetime expectancy of the power supply. Therefore, two different derating curves for continuous operation can be found below:

Curve A1 Recommended output current.

Curve A2 Max allowed output current (results in approximately half the lifetime expectancy of A1).

Fig. 19-3
Mounting Orientation A
(Standard orientation)

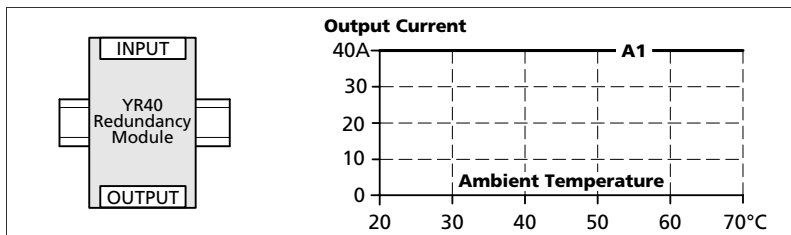

Fig. 19-4
Mounting Orientation B
(Upside down)

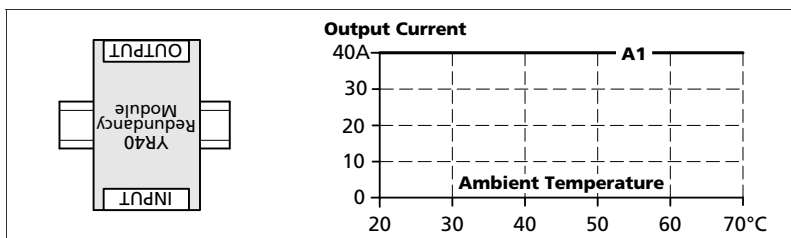

Fig. 19-5
Mounting Orientation C
(Table-top mounting)

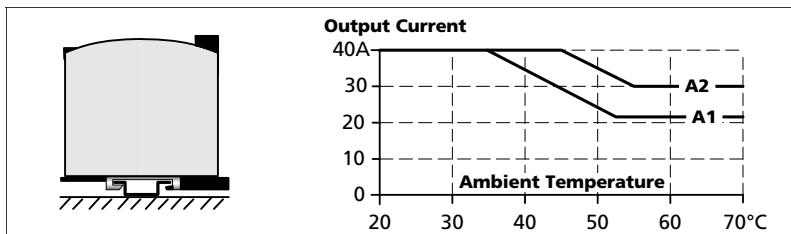

Fig. 19-6
Mounting Orientation D
(Horizontal cw)

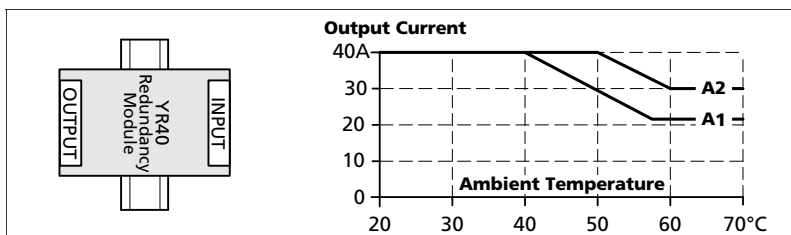

Fig. 19-7
Mounting Orientation E
(Horizontal ccw)

