



CBU-DA-1P

Instructions manual

Read this manual before installation.
Keep this manual for future reference.

WARNING: Risk of electrical shock, personal injury or death.

This device may only be installed and put into operation by qualified personnel.

Check the information of the devices to be controlled to see if they are compatible.

This device is designed for use in lighting and industrial control.

Do not use this device in equipment where malfunction may cause severe personal injury or threaten human life.

Turn power off before installing the device.

Respect national and applicable installation regulations.

If damage or malfunction should occur during operation, immediately turn power off and send device to the factory for inspection. Do not open, modify or repair the device. The device does not contain serviceable parts.

Description

CBU-DA-1P is a Casambi to DALI control device. CBU-DA-1P controller uses Bluetooth Low Energy communication to receive a command signal from the Casambi APP and convert it into DALI commands according to the selected fixture profile.

CBU-DA-1P has an integrated DALI Bus Power Supply with 100mA guaranteed current, which means that it can control up to 50 DALI LED drivers. These drivers could be also grouped into DALI groups (up to 8).

There are many Casambi fixture profiles available for CBU-DA-1P that include different control modes: Broadcast, Short Address, Groups, DT6, DT8, TW, RGBW, XY...

CBU-DA-1P also integrates a dedicated push button input for controlling Casambi devices.

Configuration and control can be done from a mobile phone or tablet using the free CASAMBI APP (available for iOS and Android).

To access [all user guides and documents](https://www.olfer.com/olfer-cbu-da-1p.html), consult below URL or scan QR code:

<https://www.olfer.com/olfer-cbu-da-1p.html>



Technical data

Nominal input voltage		110 ... 277 Vac
Input voltage range		99 ... 305 Vac
Input frequency		47 ... 63 Hz
Input current		≤ 40 mA
Power consumption		≤ 2,5W
Power consumption standby		< 0,3W
AC loop max. current		5 A
Push Button input		Normally open push button (N.O.)
Output control interface		DALI
Max. number of drivers connected		50 pcs
DALI	Bus voltage	12-14 VDC
	Guaranteed current	100 mA
	Maximum current	250 mA
RF	Communication interface	Bluetooth Low Energy (BLE) 4.0 / 5.0
	Communication protocol	Casambi
	Operating frequencies	2402–2483 MHz
	Max. transmission power	+7 dBm
Firmware update		OTA (Over The Air)
Protections		Line permanent over voltage (non replaceable fuse), line surge over voltage, over temperature.
Temperature monitoring		Internal temperature is displayed in Casambi App
Operating temperature range		-20°C ... +50°C
Connector		Screw terminals (Max. torque: 4 Lb.In / 0,5 Nm)
Wiring	Solid size	0,2 ... 3,3 mm ² / 30 ... 12 AWG
	Stranded size	
	Wire strip length	6,5 mm
IP		IP20
Enclosure material		Plastic (UL94-V0)
Dimensions		44 x 57 x 25 mm
Weight		58 g (carton box included)
Standards		EN 61347-1:2016, EN 61347-2-11:2003, EN 55015:2013, EN 61547:2011, EN 61000-3-2, EN 61000-3-3, EN 301489-1, EN 301489-17
DALI standards		IEC 62386 part 101, 103. Supports DALI-2 light and motion sensors (IEC62386 parts 303-304). Supports luminaire, energy and diagnosis data (IEC62386 parts 251-252-253)
Directives		(LVD) 2014/35/UE, (EMC) 2014/30/UE, (RED) 2014/53/UE, (RoHS) 2011/65/UE, (REACH) 1907/2006.

Wiring diagram

➤ Control of one or multiple DALI devices as external control device:

- No limit for AC current consumption of attached LED drivers.
- Recommended.

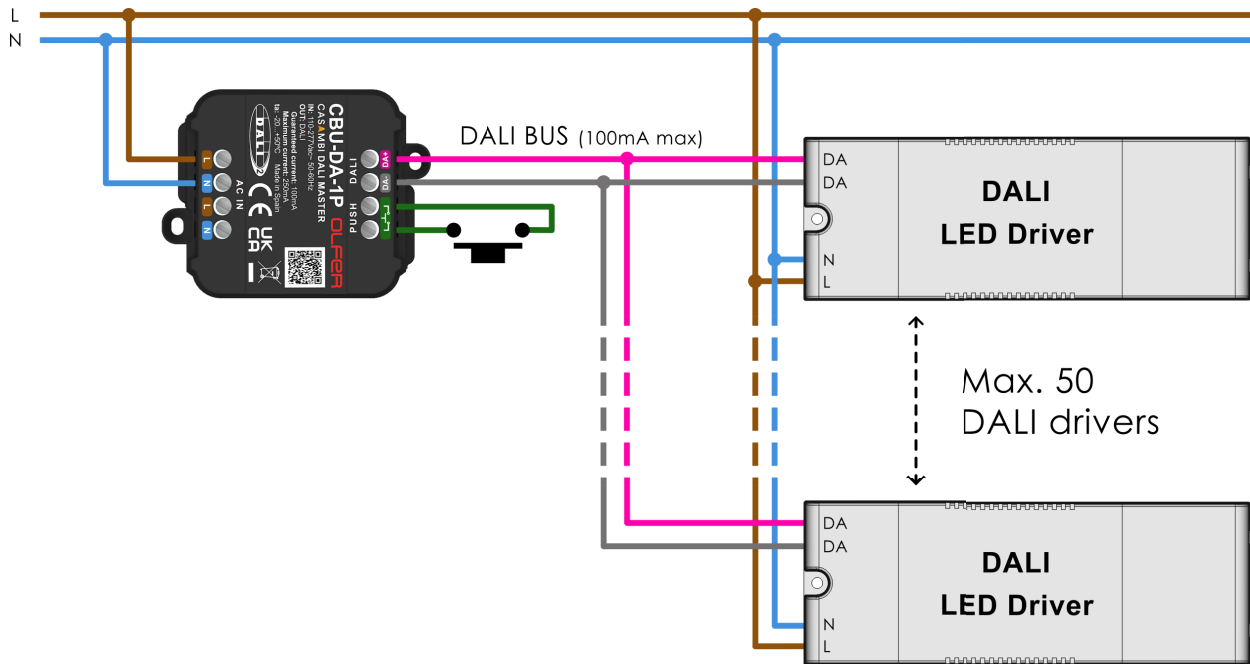

➤ Integration into lighting fixtures:

- Limit for AC current consumption of attached LED driver/s -> **5A max.**
- Not allowed when AC current consumption of LED driver/s is unknown or above 5 A.
- Not recommended unless you need to save space/terminals by using AC loop feature.

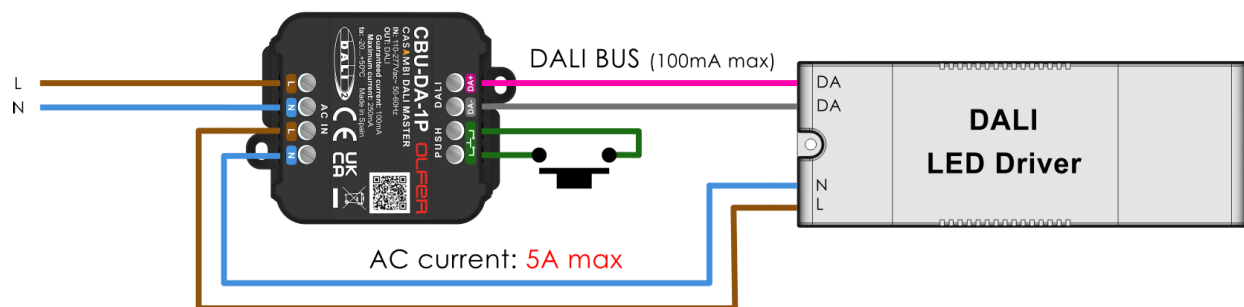

Installation instructions

Make sure that the mains voltage is switched off when making any connections. Use 0,2 - 3,3 mm² solid or stranded conductor electrical wires. Strip the wire 6,5mm from the end.

Insert the wires to the corresponding holes and tighten the connector screw. Max. torque is 4 Lb.In / 0,5 Nm. Make sure to connect the input and outputs correctly.

Mains terminals L/N are duplicated and internally connected in pairs. When attached LED drivers are powered through CBU-DA-1P free L/N terminals, make sure that total AC current consumption of attached LED drivers is below 5A.

DALI output is marked with “**DA+**” and “**DA-**” symbols. Max. DALI bus current consumption allowed is 100mA which means that the max. number of certified DALI drivers that can be connected is 50 pcs. Using non-certified drivers could reduce this max. number. Before connecting CBU-DA-1P to a DALI line, please make sure that no other DALI Bus Power Supply is powering the bus.

PUSH input is marked with “**⏏**” symbol. The maximum recommended wiring distance between the push button and terminals is 100 meters (installations with strong electromagnetic interferences may require the use of shielded cable). Push button input is only ready to connect a normally open push button. Make sure not to connect live parts to the PUSH terminals.

CBU-DA-1P is a built-in device. It is intended to be integrated into a lighting fixture or inside a cabinet/junction box.

If you install CBU-DA-1P into a heat sensitive environment (i.e inside a luminaire or in a ceiling outlet box above a luminaire), make sure that the ambient temperature does not exceed the specified maximum value. The device shouldn't be covered by insulators such as rock wool.

CBU-DA-1P, as any other Casambi product, should not be placed in a metal enclosure or next to large metal structures. Metal will effectively block radio signals which are crucial to the operation of the product.

When the product is mounted inside a metal case (e.g. integrated into a metal light fixture), a cut-out around the antenna may be needed for allowing the RF signal to exit the structure. The cut-out area should be as large as possible. Also the device should be placed as far away from any vertical structures as possible.

Also mains wires should be placed as far as possible from the antenna area. CBU-DA-1P's antenna is placed in the right side of the device (next location marked in yellow):



Effective range is also highly dependent on the surrounding and obstacles, such as walls and building materials. A thorough connectivity testing is strongly recommended in the installation site.

When CBU-DA-1P is installed and powered, it can be configured and paired to a net using Casambi App. Unpaired devices will appear in nearby devices list of Casambi App. Select the most suitable profile for the application before pairing CBU-DA-1P to a net. The updated available fixture profiles list is available at the [product webpage](#).

If the device is already paired to a network for which you don't have credentials and you wish to pair it to a new network, please go to “Nearby devices”->Tap on device's icon-> Tap “Unpair device”. Once the unpairing sequence has started, switch off the mains power supply and switch it on again within 1-2 seconds. If you do the procedure too quickly, the unpairing may not work properly. Repeat the unpairing sequence, allowing an extra 1 or 2 seconds to pass between the instant in which the mains power supply is switched off and on again. A second method to unpair the device is to connect a normally open push button to the PUSH terminals of the CBU-DA-1P and during the unpairing procedure press the button.

ELECTRONICA OLFER, S.L.
Av. Industria, 6-8. P.A.E. NEISA Avance I. 28108 Alcobendas SPAIN.

We reserve the right to make any changes without notice in the information reflected herein, not being liable for any harm that this may cause.