



DC/DC CONVERTER

- 48V DC-input
- Isolated 24Vdc output
- Efficiency 94%
- Width only 42mm
- 20% Output power reserves (PowerBoost)
- Full power between -25°C and +60°C
- Soft-start function
- Minimal inrush current surge
- Reverse input polarity protection
- DC-OK relay contact
- Current sharing feature for parallel use
- 3 Year warranty

PRODUCT DESCRIPTION

The CD10.242 is a DIN rail mountable DC/DC converter of the highly reliable DIMENSION series. It provides a floating, stabilized and galvanically separated SELV/PELV output voltage of 24Vdc with 48Vdc on the input.

The efficiency of 94% and a slim design are cost- and space-saving. The devices also offer PowerBoost: Power reserves of 20%, which may even be used continuously at temperatures up to +45°C.

For even higher power needs, multiple devices can be connected in parallel. At any time, a DC-OK LED and a signal contact are informing about the status of the device.

A high immunity to transients and power surges as well as low electromagnetic emission makes this DC/DC converter suitable for nearly every situation.

For 24Vdc/24Vdc or 48Vdc/48Vdc converters, please see PULS products CD10.241 resp. CD10.482.

SHORT-FORM DATA

Output voltage	DC 24V	Nominal
Adjustment range	24 - 28V	Factory setting 24.1V
Output current	10.0 - 8.6A	Up to +60°C ambient
	7.5 - 6.5A	At +70°C ambient
	Derate linearly between +60°C and +70°C	
PowerBoost	12A	Up to +45°C ambient
	Linear decrease to nominal power between +45°C and +60°C	
Input voltage	DC 48V	±25%
Input current	5.4A	
Input inrush current	5.8A peak	
Efficiency	94%	
Power losses	15.4W	
Hold-up time	7ms	
Temperature range	-25°C to +70°C	
Size (W x H x D)	42x124x117mm	Without DIN rail
Weight	520g	

ORDER NUMBERS

DC/DC Converter

CD10.242

Mechanical Accessory

ZM10.WALL Wall/panel mount bracket

ZM12.SIDE Side mount bracket

MAIN APPROVALS

For details and the complete approval list, see chapter 19.



INDEX

	Page		Page
1. Intended Use	3	19. Approved, Fulfilled or Tested Standards.....	20
2. Installation Instructions.....	3	20. Regulatory Product Compliance	20
3. DC-Input	5	21. Physical Dimensions and Weight	21
4. Input Inrush Current.....	7	22. Accessories.....	22
5. Soft-start Feature	7	22.1. ZM10.Wall - Wall/Panel Mount Bracket	22
6. Output.....	8	22.2. ZM12.SIDE - Side Mount Bracket	23
7. Hold-up Time.....	10	22.3. UF20.241 Buffer Module.....	24
8. DC-OK Relay Contact	11	22.4. YR40.241 - Redundancy Module	24
9. Efficiency and Power Losses.....	12	23. Application Notes.....	25
10. Functional Diagram	13	23.1. Peak Current Capability.....	25
11. Front Side and User Elements	13	23.2. Output Circuit Breakers.....	26
12. Terminals and Wiring	14	23.3. Charging of Batteries.....	26
13. Lifetime Expectancy	15	23.4. Series Operation.....	27
14. MTBF	15	23.5. Parallel Use to Increase Output Power	27
15. EMC.....	16	23.6. Parallel Use for Redundancy	28
16. Environment.....	17	23.7. Use in a Tightly Sealed Enclosure	29
17. Safety and Protection Features.....	18	23.8. Mounting Orientations.....	30
18. Dielectric Strength.....	19		

The information given in this document is correct to the best of our knowledge and experience at the time of publication. If not expressly agreed otherwise, this information does not represent a warranty in the legal sense of the word. As the state of our knowledge and experience is constantly changing, the information in this data sheet is subject to revision. We therefore kindly ask you to always use the latest issue of this document (available under www.pulspower.com).

No part of this document may be reproduced or utilized in any form without our prior permission in writing.

TERMINOLOGY AND ABBREVIATIONS

PE and  symbol	PE is the abbreviation for Protective Earth and has the same meaning as the symbol  .
Earth, Ground	This document uses the term "earth" which is the same as the U.S. term "ground".
t.b.d.	To be defined, value or description will follow later.
DC 48V	A figure displayed with the AC or DC before the value represents a nominal voltage with standard tolerances included. E.g.: DC 12V describes a 12V battery disregarding whether it is full (13.7V) or flat (10V)
48Vdc	A figure with the unit (Vac) at the end is a momentary figure without any additional tolerances included.
may	A key word indicating flexibility of choice with no implied preference.
shall	A key word indicating a mandatory requirement.
should	A key word indicating flexibility of choice with a strongly preferred implementation.

1. INTENDED USE

This device is designed for installation in an enclosure and is intended for commercial use, such as in industrial control, process control, monitoring, measurement, Audio/Video, information or communication equipment or the like.

Do not use this device in equipment, where malfunctioning may cause severe personal injury or threaten human life without additional appropriate safety devices, that are suited for the end-application.

If this device is used in a manner outside of its specification, the protection provided by the device may be impaired.

2. INSTALLATION INSTRUCTIONS



WARNING

Risk of electrical shock, fire, personal injury or death.

- Turn power off before working on the device and protect against inadvertent re-powering.
- Do not open, modify or repair the device.
- Use caution to prevent any foreign objects from entering into the housing.
- Do not use in wet locations or in areas where moisture or condensation can be expected.
- Do not touch during power-on, and immediately after power-off. Hot surface may cause burns.

Obey the following installation requirements:

This device may only be installed and put into operation by qualified personnel.

This device does not contain serviceable parts. The tripping of an internal fuse is caused by an internal defect.

If damage or malfunction should occur during installation or operation, immediately turn power off and send unit to the factory for inspection.

Install device in an enclosure providing protection against electrical, mechanical and fire hazards. Install the device onto a DIN rail according to EN 60715 with the input terminals on the bottom of the device. Other mounting orientations require a reduction in output current.

Make sure that the wiring is correct by following all local and national codes. Use appropriate copper cables that are designed for a minimum operating temperature of 60°C for ambient temperatures up to +45°C, 75°C for ambient temperatures up to +60°C and 90°C for ambient temperatures up to +70°C. Ensure that all strands of a stranded wire enter the terminal connection. Unused screw terminals should be securely tightened.

The device is designed for pollution degree 2 areas in controlled environments. No condensation or frost is allowed.

The enclosure of the device provides a degree of protection of IP20. The enclosure does not provide protection against spilled liquids.

The isolation of the devices is designed to withstand impulse voltages up to 1.5kV according to IEC 60664-1.

The input can be powered from batteries or similar DC sources. The voltage between the input terminals and ground must not exceed 60Vdc continuously. The input must be powered from a PELV or SELV source or an "Isolated Secondary Circuit" in order to maintain a SELV or PELV output.

Check for correct input polarity. The device will not operate when the voltage is reversed. A disconnecting means shall be provided for the input of the device.

The device is designed as "Class of Protection I" equipment according to IEC 61140. Do not use without a proper PE (Protective Earth) connection.

The device is designed for convection cooling and does not require an external fan. Do not obstruct airflow and do not cover ventilation grid!

The device is designed for altitudes up to 5000m. Above 2000m a reduction in output current is required.

Keep the following minimum installation clearances: 40mm on top, 20mm on the bottom, 5mm left and right side. Increase the 5mm to 15mm in case the adjacent device is a heat source. When the device is permanently loaded with less than 50%, the 5mm can be reduced to zero.

The device is designed, tested and approved for branch circuits up to 50A without additional protection device. If an external fuse is utilized, do not use circuit breakers smaller than 16A B- or C-Characteristic to avoid a nuisance tripping of the circuit breaker.

The maximum surrounding air temperature is +70°C. The operational temperature is the same as the ambient or surrounding air temperature and is defined 2cm below the device.

The device is designed to operate in areas between 5% and 95% relative humidity.

3. DC-INPUT

The input can be powered from batteries or similar DC sources and must be a PELV or SELV source or an "Isolated Secondary Circuit" in order to maintain a SELV or PELV output.

Check for correct input polarity. The device will not operate when the voltage is reversed.

DC input	nom.	DC 48V	±25%
DC input range		36-60Vdc	
Allowed voltage between input and earth/ground	max.	60Vdc or 42.2Vac	According to IEC 62477-1
Allowed input ripple voltage	max.	10Vpp	In the frequency range from 47 to 500Hz, the momentary input voltage must always be within the specified limits.
Turn-on voltage	typ.	35Vdc	Steady-state value, see Fig. 3-1
Shut-down voltage	typ.	32Vdc	Steady-state value, see Fig. 3-1
Input current	typ.	5.4A	At 48Vdc input and 24V, 10A output load, see Fig. 3-3
	typ.	7.5A	At 36Vdc input and 24V, 10A output load, see Fig. 3-3
Start-up delay	typ.	200ms	See Fig. 3-1
Rise time	typ.	150ms	At 24V, 10A constant current load, 0mF load capacitance, see Fig. 3-2
	typ.	250ms	At 24V, 10A constant current load, 5mF load capacitance, see Fig. 3-2
Turn-on overshoot	max.	500mV	See Fig. 3-2
Input capacitance	typ.	1 650µF	Installed inside the device, external capacitors on the input are allowed without any limitations.
External input protection		See recommendations in chapter 2.	

Fig. 3-1 Input voltage range

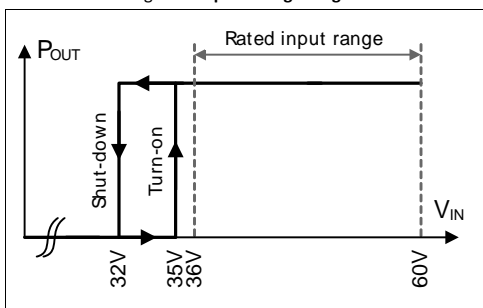

Fig. 3-2 Turn-on behavior, definitions

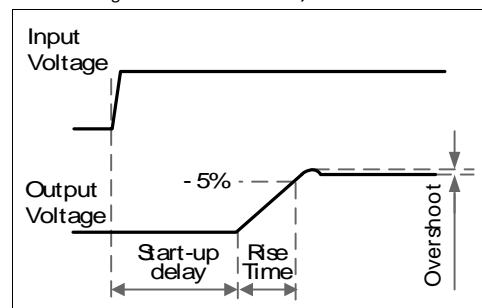
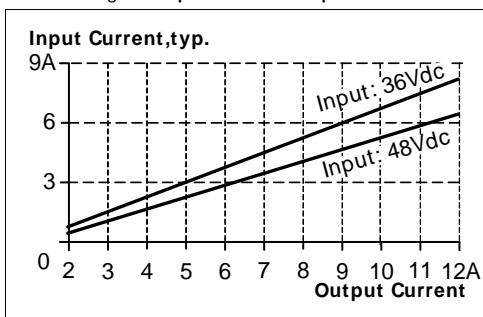

Fig. 3-3 Input current vs. output load



Requirements for the Supplying Source

In certain circumstances, the input filter of the DC/DC converter can show a resonant effect which is caused by the supplying network. Especially when additional external input filters are utilized, a superimposed AC voltage can be generated on the input terminals of the DC/DC converter which might cause a malfunction of the unit. Therefore, additional input filters are not recommended. To avoid the resonant effects, the minimal resistance of the supplying network which depends on the inductance of the input network, shall be above the boundary curve in Fig. 3-4.

Fig. 3-4 External input filter requirements to avoid filter instabilities

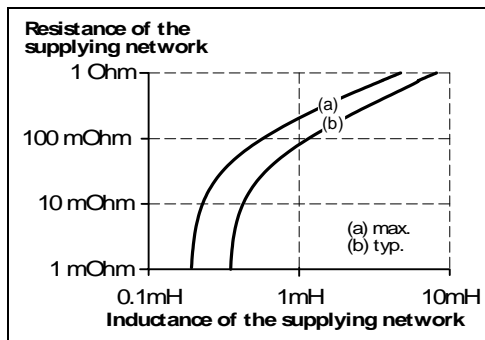

4. INPUT INRUSH CURRENT

An active inrush limitation circuit (inrush limiting NTC resistor which is bypassed by a MOSFET) limits the input inrush current after turn-on of the input voltage.

The charging current into EMI suppression capacitors is disregarded in the first microseconds after switch-on.

Inrush current	max.	8A _{peak}	At 40°C, cold start
	typ.	7A _{peak}	At 40°C, cold start
	typ.	5.8A _{peak}	At 25°C, cold start
Inrush energy	max.	1A ² s	At 40°C, cold start

Fig. 4-1 Typical input inrush current behavior at nominal load and 25°C ambient

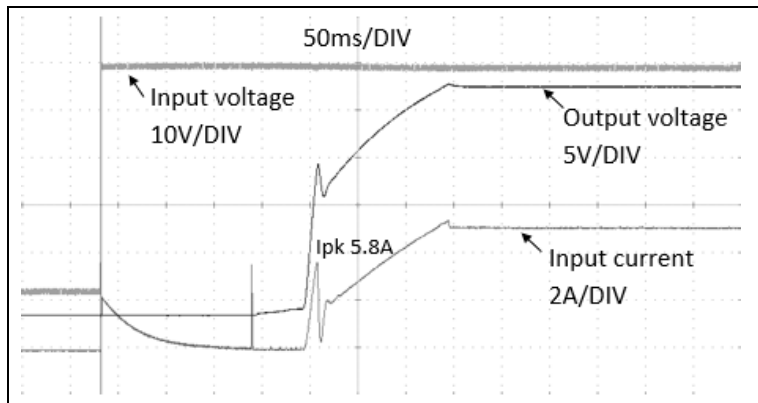

5. SOFT-START FEATURE

After the DC/DC converter is turned on, the internal output current rises slowly to its nominal value. This method charges the output capacitors (internal and external capacitors) slowly and avoids high input currents during turn-on. High input currents can produce a high voltage drop on the input wiring (especially with long and thin cables) which reduces the terminal voltage on the DC/DC converter. If the terminal voltage is below the shut-down voltage, the DC/DC converter will turn-off and will make a new start-up attempt. This effect is avoided with the integrated soft-start function. Please note that this function increases the rise time of the output voltage by a small amount.

6. OUTPUT

The output provides a SELV/PELV rated voltage, which is galvanically isolated from the input voltage and is designed to supply any kind of loads, including unlimited capacitive and inductive loads.

The output is electronically protected against overload, no-load and short-circuits. In case of a protection event, audible noise may occur.

Output voltage	nom.	24V	
Adjustment range		24-28V	Guaranteed value
	max.	30V	This is the maximum output voltage which can occur at the clockwise end position of the potentiometer due to tolerances. It is not a guaranteed value which can be achieved.
Factory setting		24.1V	±0.2%, at full load, cold unit
Line regulation	max.	25mV	Between 36 and 60Vdc input voltage variation
Load regulation	max.	100mV	In "single use" mode: static value, 0A → 10A, see Fig. 6-2
	typ.	1000mV	In "parallel use" mode: static value, 0A → 10A, see Fig. 6-2
Ripple and noise voltage	max.	100mVpp	Bandwidth 20Hz to 20MHz, 50Ohm
Output current	nom.	10A	At 24V and up to +60° ambient temperature
	nom.	7.5A	At 24V and +70° ambient temperature
	nom.	8.6A	At 28V and up to +60° ambient temperature
	nom.	6.5A	At 28V and +70° ambient temperature
			Derate linearly between +60°C and +70°C, see chapter 16
PowerBoost*)	nom.	12A	At 24V and up to +45°C ambient temperature
	nom.	10.3A	At 28V and up to +45°C ambient temperature
			PowerBoost decreases linearly to nominal power between +45°C and +60°C, see chapter 16
Overload behavior		Continuous current	
Overload/ short-circuit current	max.	16A	Continuous current
	typ.		Load impedance 100mOhm
Output capacitance	typ.	4 500µF	Included inside the power supply
Back-feeding loads	max.	35V	The unit is resistant and does not show malfunctioning when a load feeds back voltage to the power supply. It does not matter whether the power supply is on or off. The absorbing energy can be calculated according to the built-in large sized output capacitor.

***) PowerBoost**

This power/ current is continuously allowed up to an ambient temperature of +45°C.

Above +45°C, do not use this power or current longer than a duty cycle of 10% and/or not longer than 1 minute every 10 minutes.

Fig. 6-1 Output voltage vs. output current at 48Vdc input voltage, typ.

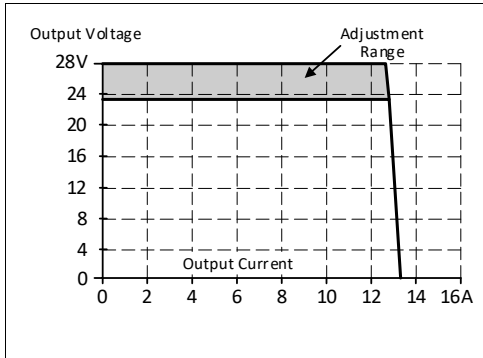
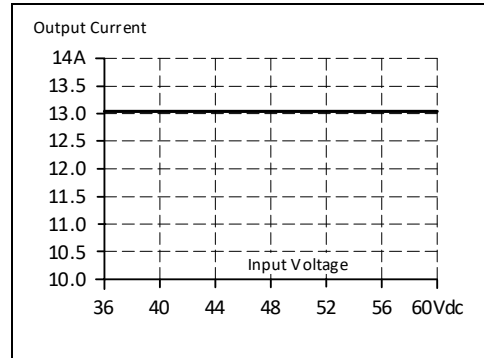

Fig. 6-2 Current limitation vs. input voltage, (23V constant voltage load), typ.



7. HOLD-UP TIME

The input side of the DC/DC converter is equipped with a bulk capacitor which keeps the output voltage alive for a certain period of time when the input voltage dips or is removed. The bulk capacitor can be discharged by loading the DC/DC converter on the output side or through a load which is parallel to the input. There is no protection in the DC/DC converter which prevents current from flowing back to the input terminals. If prevention is needed, an external diode should be used.

At no load, the hold-up time can be up to several seconds. The green DC-OK LED is also on during this time.

Hold-up Time	typ.	14ms	At 48Vdc input voltage, 24V, 5A output, see Fig. 7-1
	min.	11ms	At 48Vdc input voltage, 24V, 5A output, see Fig. 7-1
	typ.	7ms	At 48Vdc input voltage, 24V, 10A output, see Fig. 7-1
	min.	5ms	At 48Vdc input voltage, 24V, 10A output, see Fig. 7-1

Fig. 7-1 Hold-up time vs. input voltage

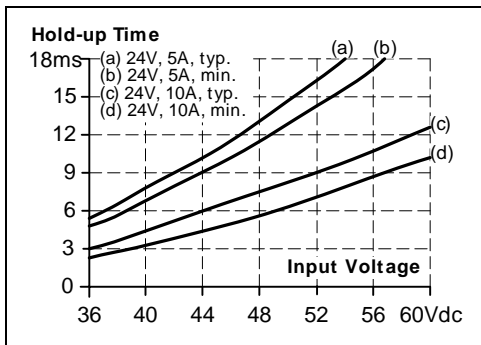

Fig. 7-2 Shut-down test setup

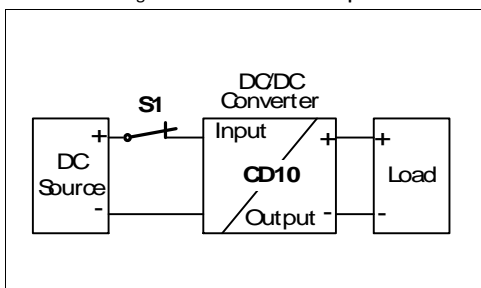
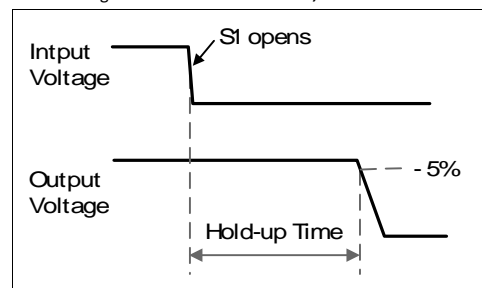

Fig. 7-3 Shut-down behavior, definitions



8. DC-OK RELAY CONTACT

This feature monitors the output voltage on the output terminals.

Threshold voltage	typ. 21V (fixed)
Contact closes	As soon as the output voltage reaches 21V.
Contact opens	As soon as the output voltage falls below 21V.
Contact ratings	Maximal 60Vdc 0.3A, 30Vdc 1A, 30Vac 0.5A, resistive load Minimal permissible load 1mA at 5Vdc
Isolation voltage	See dielectric strength table in chapter 18.

Fig. 8-1 DC-OK relay contact behavior

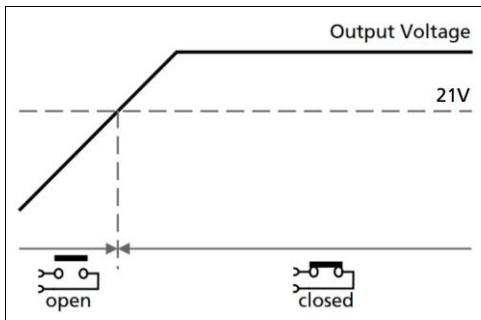

9. EFFICIENCY AND POWER LOSSES

DC 48V			
Efficiency	typ.	94.0%	At 24V, 10A
	typ.	93.5%	At 24V, 12A (PowerBoost)
Average efficiency*)	typ.	93.8%	At 25% at 2.5A, 25% at 5A, 25% at 7.5A, 25% at 10A
Power losses	typ.	1.2W	At no output load
	typ.	7.5W	At 24V, 5A
	typ.	15.4W	At 24V, 10A
	typ.	20W	At 24V, 12A (PowerBoost)

*) The average efficiency is an assumption for a typical application where the power supply is loaded with 25% of the nominal load for 25% of the time, 50% of the nominal load for another 25% of the time, 75% of the nominal load for another 25% of the time and with 100% of the nominal load for the rest of the time.

Fig. 9-1 Efficiency vs. output current at 24V, typ.

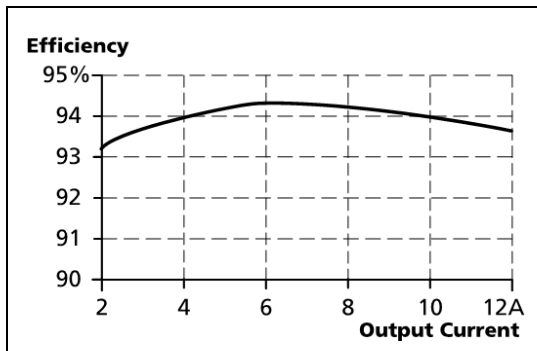

Fig. 9-2 Losses vs. output current at 24V, typ.

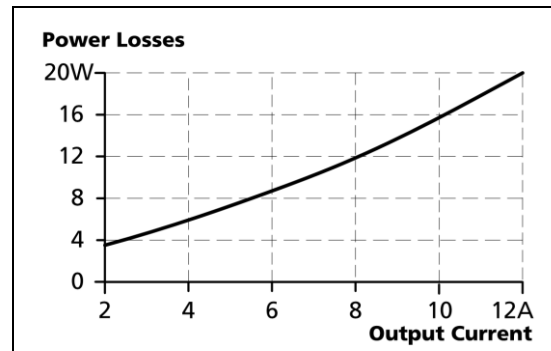

Fig. 9-3 Efficiency vs. input voltage at 48V, 10A, typ.

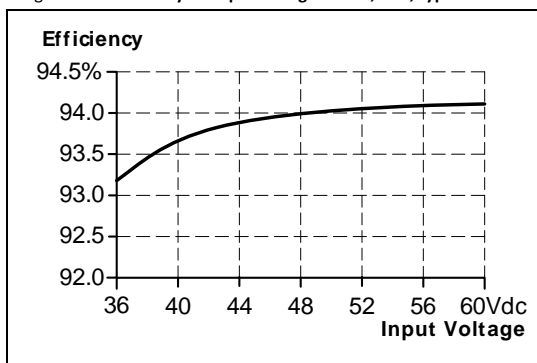
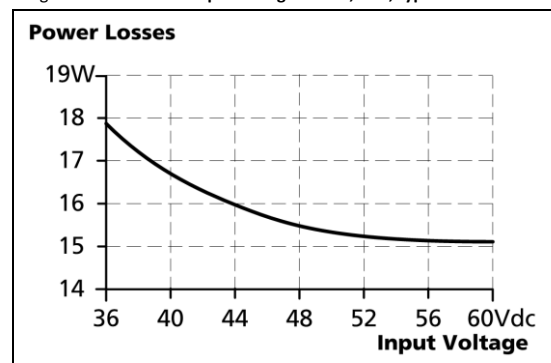
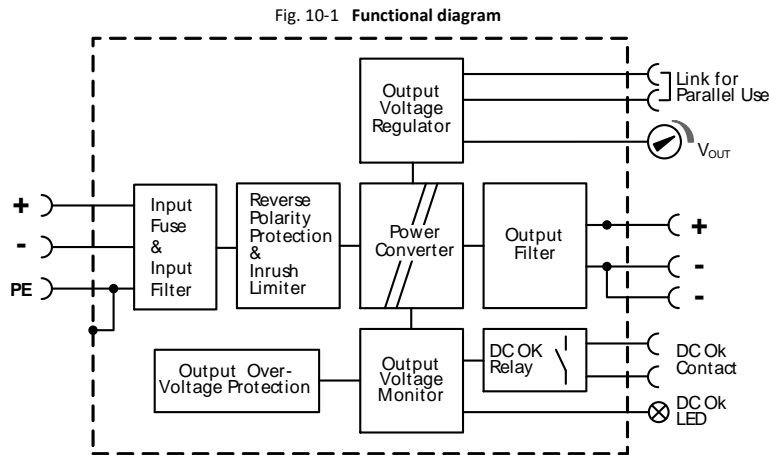

Fig. 9-4 Losses vs. input voltage at 48V, 10A, typ.



10. FUNCTIONAL DIAGRAM



11. FRONT SIDE AND USER ELEMENTS

Fig. 11-1 Front side

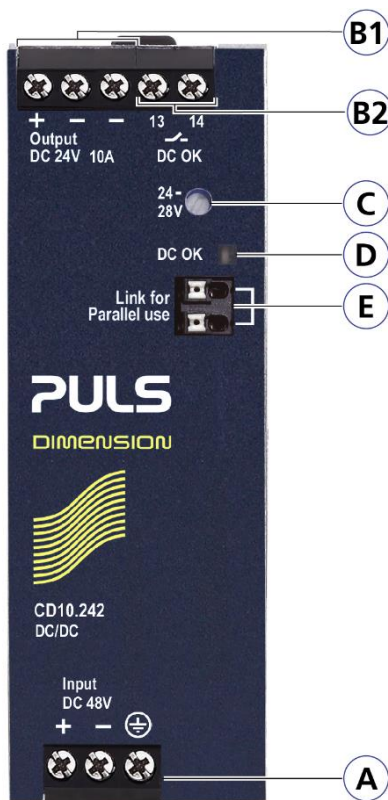

A Input terminals

- + Positive input
- Negative input
- PE --> Protective Earth (Ground) connection

B1 Output terminals

- Single terminal for the positive pole and dual terminals for the negative pole. Both negative poles are internally connected.
- + Positive output
- Negative (return) output

B2 DC-OK relay contact

- The DC-OK relay contact is synchronized with the DC-OK LED.
- See chapter 8 for details.

C Output voltage potentiometer

D DC-OK LED (green)

- The LED is on, when the output voltage is above 21V.

E "Parallel Use" "Single Use" link

- Link the two terminal poles when outputs of devices are connected in parallel. In order to achieve a sharing of the load current between the individual devices, the "parallel use" regulates the output voltage in such a manner that the voltage at no load is approx. higher than at nominal load.
- See chapter 23.5 for details.

12. TERMINALS AND WIRING

The terminals are IP20 Finger safe constructed and suitable for field- and factory wiring.

	Input	Output	Signal terminal
Type	Screw terminals	Screw terminals	Push-in terminal
Solid wire	max. 6mm ²	max. 6mm ²	Max. 1.5mm ²
Stranded wire	max. 4mm ²	max. 4mm ²	Max. 1.5mm ²
American Wire Gauge	20-10 AWG	20-10 AWG	24-16 AWG
Max. wire diameter (including ferrules)	2.8mm	2.8mm	1.6mm
Recommended tightening torque	1Nm	1Nm	-
Wire stripping length	7mm	7mm	7mm
Screwdriver	3.5mm slotted or Phillips No 1	3.5mm slotted or Phillips No 1	3mm slotted to open the spring

Daisy chaining of outputs:

Daisy chaining (jumping from one DC/DC-converter output to the next) is allowed as long as the average output current through one terminal pin does not exceed 25A. If the current is higher, use a separate distribution terminal block.

Fig. 12-1 Daisy chaining of outputs

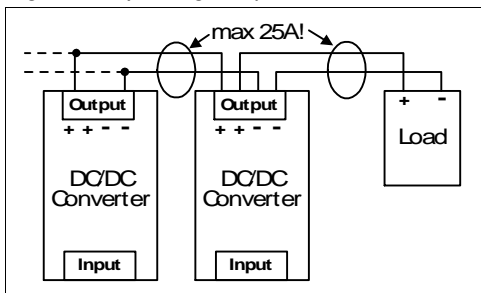
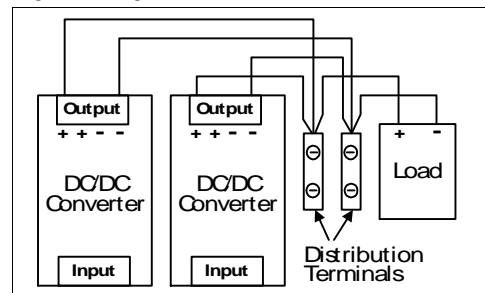

Fig. 12-2 Using distribution terminals



13. LIFETIME EXPECTANCY

The Lifetime expectancy shown in the table indicates the minimum operating hours (service life) and is determined by the lifetime expectancy of the built-in electrolytic capacitors. Lifetime expectancy is specified in operational hours and is calculated according to the capacitor's manufacturer specification. The manufacturer of the electrolytic capacitors only guarantees a maximum life of up to 15 years (131 400h). Any number exceeding this value is a calculated theoretical lifetime which can be used to compare devices.

	Input 48Vdc	
Lifetime expectancy	275 000h	At 24V, 5A and 40°C
	117 000h	At 24V, 10A and 40°C
	70 000h	At 24V, 12A and 40°C
	788 000h	At 24V, 5A and 25°C
	327 000h	At 24V, 10A and 25°C
	197 000h	At 24V, 12A and 25°C

14. MTBF

MTBF stands for **Mean Time Between Failure**, which is calculated according to statistical device failures, and indicates reliability of a device. It is the statistical representation of the likelihood of a unit to fail and does not necessarily represent the life of a product.

The MTBF figure is a statistical representation of the likelihood of a device to fail. A MTBF figure of e.g. 1 000 000h means that statistically one unit will fail every 100 hours if 10 000 units are installed in the field. However, it cannot be determined if the failed unit has been running for 50 000h or only for 100h.

For these types of units the MTTF (**Mean Time To Failure**) value is the same value as the MTBF value.

	Input 48Vdc	
MTBF SN 29500, IEC 61709	765 000h	At 24V, 10A and 40°C
	1 363 000h	At 24V, 10A and 25°C
MTBF MIL HDBK 217F	358 000h	At 10A and 40°C; Ground Benign GB40
	403 000h	At 10A and 25°C; Ground Benign GB25
	66 000h	At 10A and 40°C; Ground Fixed GF40
	90 000h	At 10A and 25°C; Ground Fixed GF25

15. EMC

The EMC behavior of the device is designed for applications in industrial environment as well as in residential, commercial and light industry environments.

The device is investigated according to the generic standards EN 61000-6-1, EN 61000-6-2, EN 61000-6-3, EN IEC 61000-6-8 and EN 61000-6-4.

EMC Immunity	Power lines and housing			
Electrostatic discharge	EN 61000-4-2	Contact discharge	8kV	Criterion A
		Air discharge	15kV	Criterion A
Electromagnetic RF field	EN 61000-4-3	80MHz-2.7GHz	20V/m	Criterion A
		2.7GHz-6.0GHz	10V/m	Criterion A
Fast transients (Burst)	EN 61000-4-4	Input lines	4kV	Criterion A
		Output lines	2kV	Criterion A
Surge voltage on input	EN 61000-4-5	+ → -	1kV	Criterion A
		+/- → chassis ground	2kV	Criterion A
Surge voltage on output	EN 61000-4-5	+ → -	500V	Criterion A
		+ / - → chassis ground	1kV	Criterion A
Conducted disturbance	EN 61000-4-6	0.15-80MHz	20V	Criterion A

EMC Immunity	DC-OK signal lines			
Electromagnetic RF field	EN 61000-4-3	80MHz-2.7GHz	20V/m	Criterion A
		2.7GHz-6.0GHz	10V/m	Criterion A
Fast transients (Burst)	EN 61000-4-4	DC-OK lines with coupling clamp	2kV	Criterion A
Surge	EN 61000-4-5	DC-OK lines → chassis ground	1kV	Criterion A
Conducted disturbance	EN 61000-4-6	0.15-80MHz	20V	Criterion A

Criteria:

A: The device shows normal operation behavior within the defined limits.

EMC Emission

Conducted emission on input lines	IEC/CISPR 16-1-2, IEC/CISPR 16-2-1	Limits for DC power networks according to EN 61000-6-3 fulfilled
Conducted emission on output lines	IEC/CISPR 16-1-2, IEC/CISPR 16-2-1	Limits for DC power networks according to EN IEC 61000-6-8 fulfilled
Radiated emission	EN 55011, EN 55032	Class B

This device complies with FCC Part 15 rules.

Operation is subjected to following two conditions: (1) this device may not cause harmful interference, and (2) this device must accept any interference received, including interference that may cause undesired operation.

Switching Frequency

Main converter	75kHz to 500kHz	Output load and input voltage dependent
----------------	-----------------	---

16. ENVIRONMENT

Operational temperature	-25°C to +70°C	The operational temperature is the ambient or surrounding temperature and is defined as the air temperature 2cm below the device.
Storage temperature	-40°C to +85°C	For storage and transportation
Output derating	3.2W/°C 6W/K 15W/1000m or 5K/1000m 9W/-5kPa or 3°C/-5kPa	Between +45°C and +60°C Between +60°C and +70°C For altitudes >2000m, see Fig. 15-2 For atmospheric pressures <80kPa, see Fig. 15-2
	The derating is not hardware controlled. The customer has to take care by himself to stay below the de-rated current limits in order not to overload the unit.	
Humidity	5 to 95% r.h.	According to IEC 60068-2-30
Atmospheric pressure	110-47kPa	See Fig. 15-2 for details
Altitude	Up to 5000m	See Fig. 15-2 for details
Degree of pollution	2	According to IEC 62477-1, not conductive
Vibration sinusoidal	2-17.8Hz: ±1.6mm; 17.8-500Hz: 2g 2 hours / axis	According to IEC 60068-2-6
Shock	30g 6ms, 20g 11ms 3 bumps / direction, 18 bumps in total	According to IEC 60068-2-27
	Shock and vibration is tested in combination with DIN rails according to EN 60715 with a height of 15mm and a thickness of 1.3mm and standard orientation.	
Audible noise	Some audible noise may be emitted from the power supply during no load, overload or short circuit.	

Fig. 16-1 Output current vs. ambient temp.
(Inom 10A; Iout with PowerBoost = 12A)

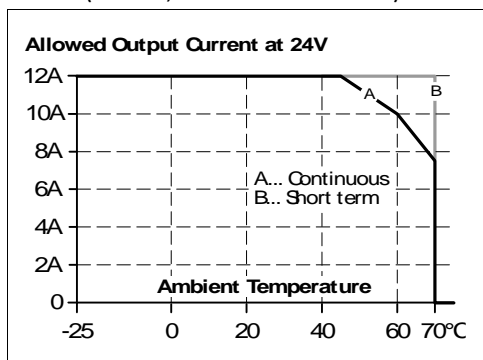
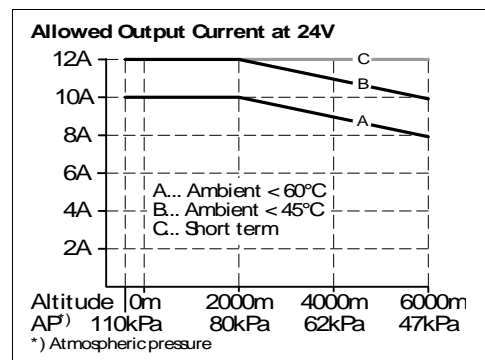

Fig. 16-2 Output current vs. altitude



17. SAFETY AND PROTECTION FEATURES

Isolation resistance	min.	500MΩ	At delivered condition between input and output, measured with 500Vdc
	min.	500MΩ	At delivered condition between input and Chassis Ground, measured with 500Vdc
	min.	500MΩ	At delivered condition between output and Chassis Ground, measured with 500Vdc
	min.	500MΩ	At delivered condition between output and DC-OK contacts, measured with 500Vdc
PE resistance	max.	0.10Ω	Resistance between PE terminal and the housing in the area of the DIN rail mounting bracket.
Output over-voltage protection	typ.	31Vdc	In case of an internal defect, a redundant circuit limits the maximum output voltage. The output shuts down and automatically attempts to restart.
	max.	32.5Vdc	
Class of protection		I	According to IEC 61140
Degree of protection		IP 20	According to EN/IEC 60529
Over-temperature protection		Not included	
Input transient protection		MOV (Metal Oxide Varistor)	For protection values see chapter 15 (EMC).
Internal input fuse		Included	Not user replaceable slow-blow high-braking capacity fuse
Touch current (leakage current)		The leakage current, which is produced by the DC/DC converter itself, depends on the input voltage ripple and need to be investigated in the final application. For a smooth DC input voltage, the produced leakage current is less than 100μA.	

18. DIELECTRIC STRENGTH

The output voltage is floating and has no ohmic connection to the ground.

The output is insulated to the input by a double or reinforced insulation.

Type and routine tests are conducted by the manufacturer. Field tests may be conducted in the field using the appropriate test equipment which applies the voltage with a slow ramp (2s up and 2s down). Connect all input-terminals together as well as all output poles before conducting the test. When testing, set the cut-off current settings to the value in the table below.

We recommend that either the (+) pole or the (-) pole shall be connected to the protective earth system. This helps to avoid situations in which a load starts unexpectedly or cannot be switched off when unnoticed earth faults occur.

Fig. 18-1 Dielectric strength

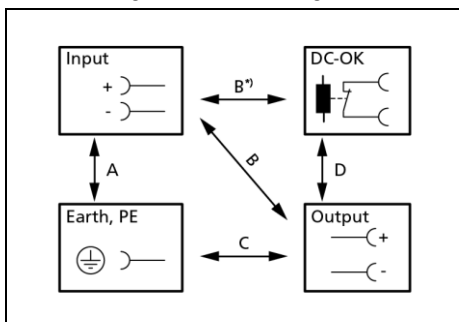

		A	B	C	D
Type test	60s	1500Vac	1500Vac	500Vac	500Vac
Routine test	5s	1500Vac	1500Vac	500Vac	500Vac
Field test	5s	1000Vac	1000Vac	500Vac	500Vac
Field test cut-off current setting		>20mA	>10mA	>12mA	>1mA

B*) When testing input to DC-OK ensure that the maximal voltage between DC-OK and the output is not exceeded (column D). We recommend connecting DC-OK pins and the output pins together when performing the test.

19. APPROVED, FULFILLED OR TESTED STANDARDS

VDMA 24364



Paint Wetting Impairment Substances Test (or LABS-Test)
Tested for Zone 2 and test class C1 according to VDMA 24364-C1-L/W for solvents and water-based paints

20. REGULATORY PRODUCT COMPLIANCE

EU Declaration of Conformity



The CE mark indicates conformance with the
- EMC directive
- RoHS directive

REACH Regulation (EU)



Manufacturer's Declaration
EU regulation regarding the Registration, Evaluation, Authorisation and Restriction of Chemicals (REACH) fulfilled.
EU Regulation (EC) 1907/2006.

WEEE Regulation



Manufacturer's Declaration
EU Regulation on Waste Electrical and Electronic Equipment
Registered as business to business (B2B) products.
EU Regulation 2012/19/EU

21. PHYSICAL DIMENSIONS AND WEIGHT

Width	42mm
Height	124mm
Depth	117mm The DIN rail depth must be added to the unit depth to calculate the total required installation depth.
Weight	520g
DIN rail	Use 35mm DIN rails according to EN 60715 or EN 50022 with a height of 7.5 or 15mm.
Housing material	Body: Aluminium alloy Cover: Zinc-plated steel
Installation clearances	See chapter 2
Penetration protection	Small parts like screws, nuts, etc. with a diameter larger than 3.5mm

Fig. 21-1 Front view

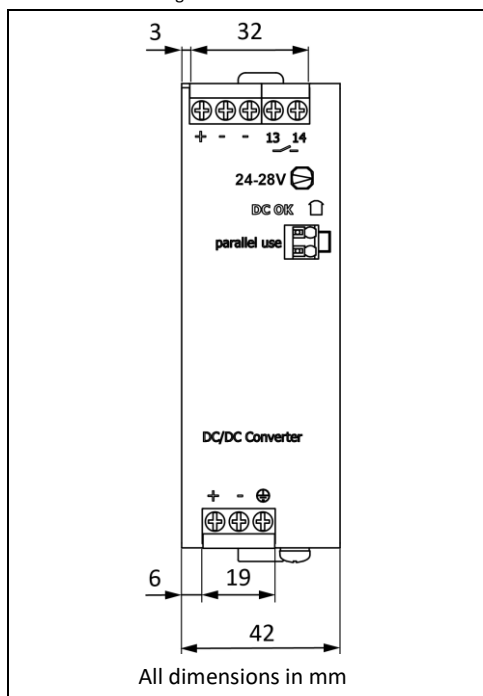
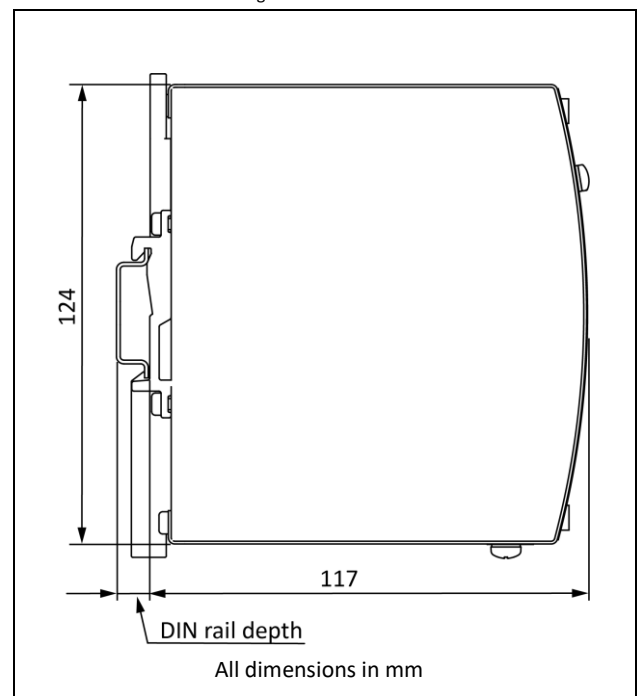

Fig. 21-2 Side view



22. ACCESSORIES

22.1. ZM10.WALL - WALL/PANEL MOUNT BRACKET

This bracket is used to mount the devices on a wall/panel without utilizing the DIN rail. The bracket can be mounted without detaching the DIN rail brackets from the power supply.

Fig. 22-1 Isometric view

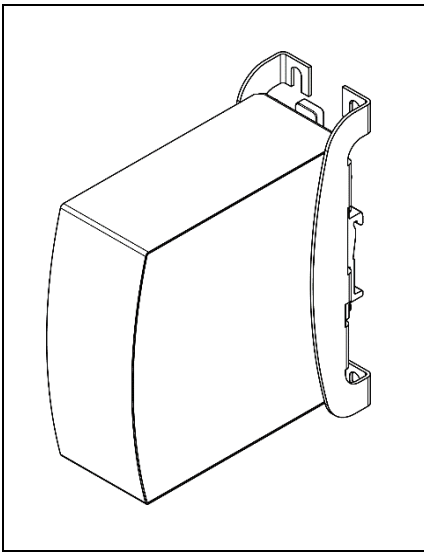

Fig. 22-2 Isometric view

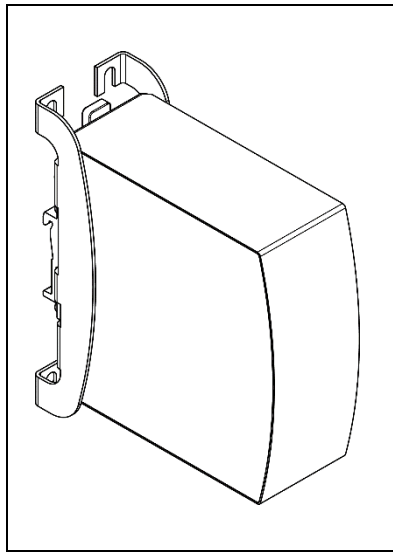

Fig. 22-3 Isometric view

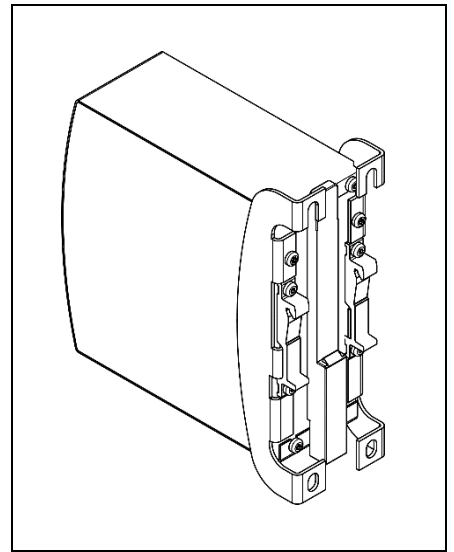

Fig. 22-4 Wall/panel mounting, front view

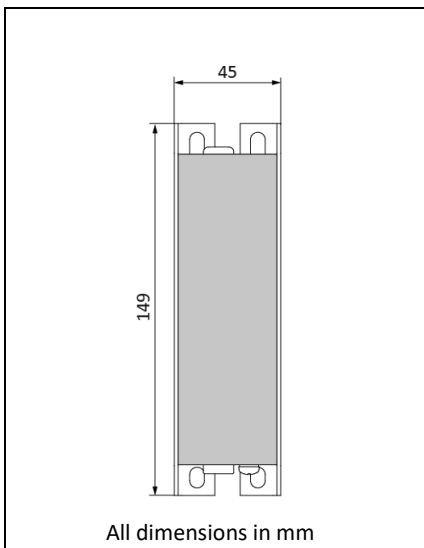

Fig. 22-5 Hole pattern for wall mounting

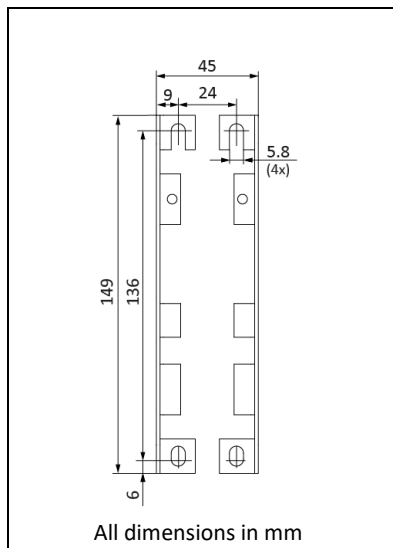
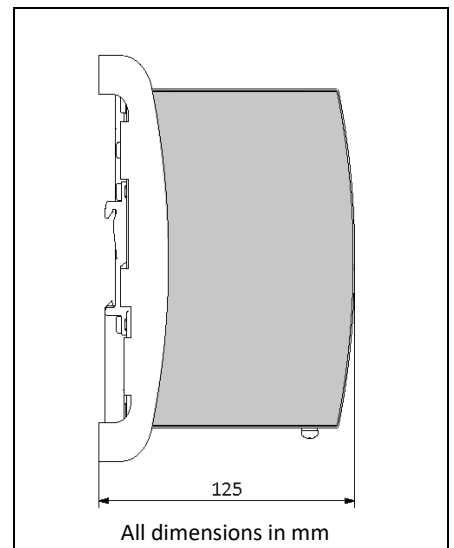

Fig. 22-6 Wall/panel mounting, side view



22.2. ZM12.SIDE - SIDE MOUNT BRACKET

This ZM12.SIDE bracket is used to mount the device sideways with or without utilizing a DIN rail to save installation depth.

The two aluminum brackets and the black plastic slider of the unit have to be detached, so that the ZM12.SIDE steel bracket can be mounted.

For sideways DIN rail mounting, the removed aluminum brackets and the black plastic slider need to be mounted on the ZM12.SIDE steel bracket.

PSU for illustration purpose only.



Fig. 22-7 Side mounting without DIN rail brackets

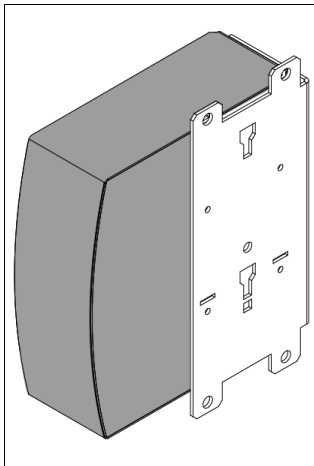

Fig. 22-8 Side mounting with DIN rail brackets

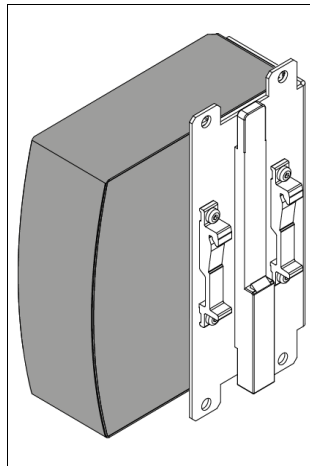
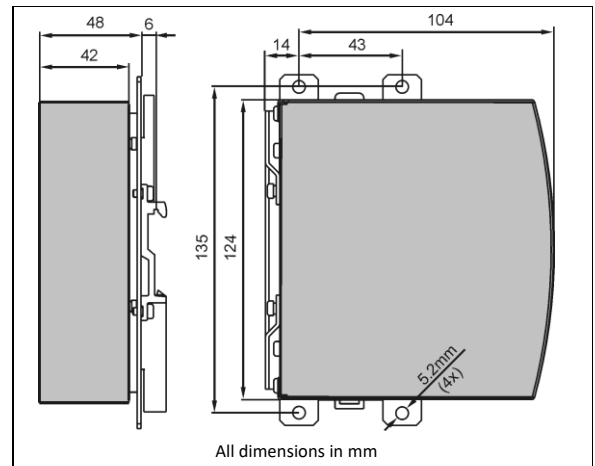
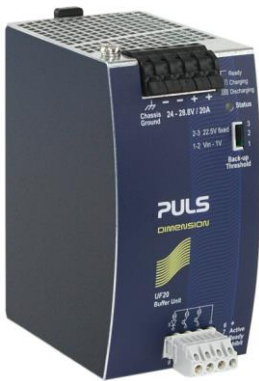

Fig. 22-9 Hole pattern



22.3. UF20.241 BUFFER MODULE



The UF20.241 buffer module is a supplementary device for 24V DC/DC converters. It delivers power to bridge typical supply voltage faults or extends the hold-up time after the input power is turned off.

When the DC/DC converter provides a sufficient voltage, the buffer module stores energy in the integrated electrolytic capacitors. When the input voltage is lost, the stored energy is released to the DC-bus in a regulated process.

The buffer module can be added in parallel to the load circuit at any given point and does not require any control wiring.

One buffer module can deliver 20A additional current and can be added in parallel to increase the output ampacity or the hold-up time.

For longer hold-up times the UF40.241 might also be an option.

22.4. YR40.241 - REDUNDANCY MODULE



The YR40.241 is a dual redundancy module, which can be used to build 1+1 or N+1 redundant systems.

The device is equipped with two 20A nominal input channels, which are individually decoupled by utilizing MOSFET technology. The output can be loaded with a nominal 40A continuous current.

Using MOSFETs instead of diodes reduces heat generation, losses and voltage drop between input and output. Due to these advantages, the unit is very narrow and only requires 36mm width on the DIN rail.

The device does not require an additional auxiliary voltage and is self-powered even in case of a short circuit across the output.

A feature of this redundancy module is a special circuit, which keeps the losses and temperature low, even at overload and short circuit conditions up to 65A continuous current.

See chapter 12 for wiring information.

23. APPLICATION NOTES

23.1. PEAK CURRENT CAPABILITY

The unit can deliver peak currents (up to several milliseconds) which are higher than the specified short term currents.

This helps to start current demanding loads. Solenoids, contactors and pneumatic modules often have a steady state coil and a pick-up coil. The inrush current demand of the pick-up coil is several times higher than the steady-state current and usually exceeds the nominal output current. The same situation applies when starting a capacitive load.

The peak current capability also ensures the safe operation of subsequent circuit breakers of load circuits. The load branches are often individually protected with circuit breakers or fuses. In case of a short or an overload in one branch circuit, the fuse or circuit breaker need a certain amount of over-current to open in a timely manner. This avoids voltage loss in adjacent circuits.

The extra current (peak current) is supplied by the power converter and the built-in large sized output capacitors of the power supply. The capacitors get discharged during such an event, which causes a voltage dip on the output. The following two examples show typical voltage dips:

Fig. 23-1 20A Resistive peak load (2x the nominal current) for 50ms, typ.

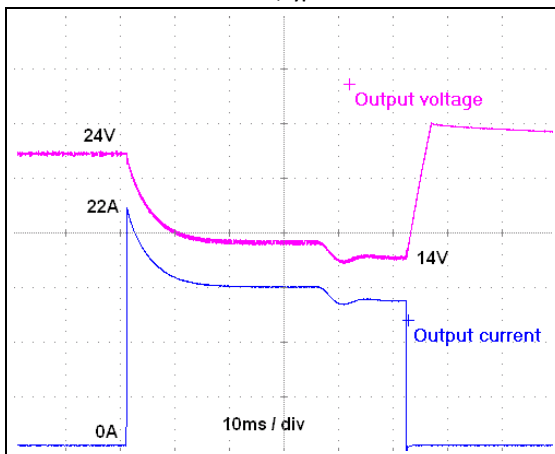
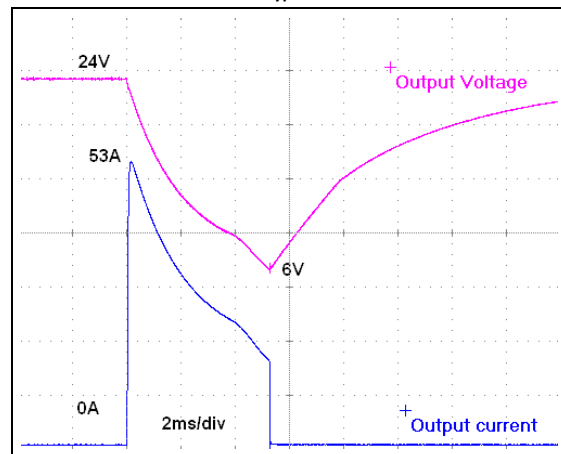

Fig. 23-2 50A Resistive peak load (5x the nominal current) for 5ms, typ.



Peak current voltage dips	typ.	from 24V to 14V	at 20A for 50ms, resistive load
	typ.	from 24V to 12V	at 40A for 2ms, resistive load
	typ.	from 24V to 6V	at 40A for 5ms, resistive load

23.2. OUTPUT CIRCUIT BREAKERS

Standard miniature circuit breakers (MCBs) are commonly used for AC supply systems, but can also be used in DC branches if specified. Such MCBs are designed to protect wires and circuits. When the ampere rating and characteristics of the MCB are matched to the wire size used, the wiring is considered thermally safe whether the MCB opens or not.

To avoid voltage dips and undervoltage situations in adjacent DC branches fed by the same source, fast (magnetic) tripping of the MCB is desirable. For example, a fast trip within 10ms avoids a shutdown and restart of the PLC. For this purpose, power supplies with high current reserves and large output capacitors are advantageous. In addition, the impedance of the faulty circuit must be sufficiently small so that the current can actually flow. The best current reserves of a power supply are of no help if Ohm's law does not allow the current to flow.

The following table provides typical test results showing which MCBs magnetically trip as a function of wire size and length. The lengths given correspond to the total length, which is the sum of the outgoing (+) and return (-) wire. The tests were performed without additional load.

Fig. 23-3 Test circuit for maximum wire length

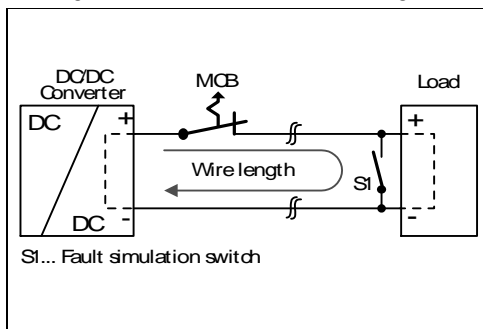

Test results for maximum wire length:

	0.75mm ²	1.0mm ²	1.5mm ²	2.5mm ²
C-2A	23m	32m	43m	62m
C-3A	14m	18m	26m	39m
C-4A	8m	9m	14m	18m
C-6A	2m	2m	4m	6m
C-8A	0m	1m	1m	1m
B-6A	11m	13m	21m	29m
B-10A	2m	2m	4m	4m
B-13A	1m	1m	1m	2m

23.3. CHARGING OF BATTERIES

The device can be used to charge lead-acid or maintenance free batteries. Four 12V SLA or VLRA batteries are needed in series connection.

Instructions for charging batteries:

- Ensure that the ambient temperature of the Device is below 45°C.
- Set output voltage, measured at no load and at the battery end of the cable, very precisely to the end-of-charge voltage.

End-of-charge voltage	27.8V	27.5V	27.15V	26.8V
Battery temperature	10°C	20°C	30°C	40°C

- Use a 16A circuit breaker or blocking diode between the Device and the battery.
- Ensure that the output current of the Device is below the allowed charging current of the battery.
- Use only matched batteries when putting 12V types in series.
- The return current to the device (battery discharge current) is typ. 10mA when the Device is switched off except in case a blocking diode is utilized.
- Do not use the devices for battery charging in mounting orientations other than the standard mounting orientation or in any other condition where a reduction of the output current is required (e.g. altitude).

23.4. SERIES OPERATION

Devices of the same type can be connected in series for higher output voltages. It is possible to connect as many units in series as needed, providing the sum of the output voltage does not exceed 150Vdc. Voltages with a potential above 60Vdc must be installed with a protection against touching.

Avoid return voltage (e.g. from a decelerating motor or battery) which is applied to the output terminals.

Keep an installation clearance of 15mm (left / right) between two power supplies and avoid installing the power supplies on top of each other. Do not use power supplies in series in mounting orientations other than the standard mounting orientation.

Pay attention that EMI and inrush current will increase when using multiple devices.

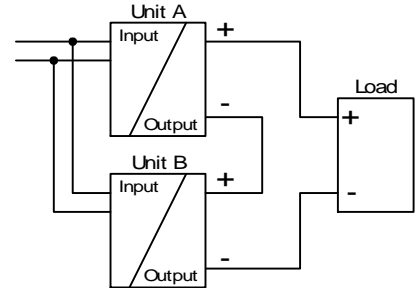

23.5. PARALLEL USE TO INCREASE OUTPUT POWER

Devices can be paralleled to increase the output power. The output voltage of all power supplies shall be adjusted to the same value ($\pm 100\text{mV}$) in "Single Use" mode with the same load conditions on all units, or the units can be left with the factory settings. After the adjustments, set the unit to "Parallel Use" mode, in order to achieve load sharing. The "Parallel Use" mode regulates the output voltage in such a manner that the voltage at no load is approx. 4% higher than at nominal load. See also chapter 6.

The ambient temperature is not allowed to exceed $+60^{\circ}\text{C}$.

If more than three devices are connected in parallel, a diode, fuse or circuit breaker with a rating of 15A or 16A is required on each output. Alternatively, a diode or redundancy module can also be utilized.

Keep an installation clearance of 15mm (left / right) between two devices and avoid installing devices on top of each other. Do not use devices in parallel in mounting orientations other than the standard mounting orientation or in any other condition where a reduction of the output current is required (e.g. altitude).

Pay attention that leakage current, EMI, inrush current will increase when using multiple devices.

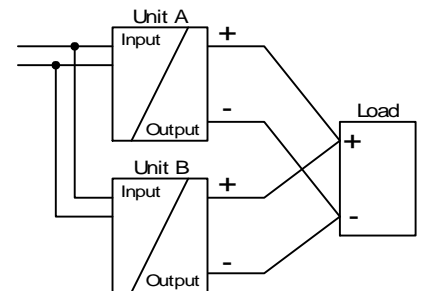

23.6. PARALLEL USE FOR REDUNDANCY

1+1 Redundancy:

Devices can be paralleled for redundancy to gain higher system availability. Redundant systems require a certain amount of extra power to support the load in case one device fails. The simplest way is to put two devices in parallel. This is called a 1+1 redundancy. In case one device fails, the other one is automatically able to support the load current without any interruption. It is essential to use a redundancy module to decouple devices from each other. This prevents that the defective unit becomes a load for the other device and the output voltage cannot be maintained any more.

1+1 redundancy allows ambient temperatures up to +70°C.

Pay attention that EMI and inrush current will increase when using multiple devices.

Recommendations for building redundant power systems:

- Use separate input fuses for each device.
- Use separate supply systems for each device whenever it is possible.
- It is desirable to set the output voltages of all devices to the same value ($\pm 100\text{mV}$) or leave it at the factory setting.

N+1 Redundancy:

Redundant systems for a higher power demand are usually built in a N+1 method. E.g. four devices, each rated for 10A are paralleled to build a 30A redundant system.

Pay attention that EMI and inrush current will increase when using multiple devices.

Keep an installation clearance of 15mm (left / right) between two devices and avoid installing the devices on top of each other.

Do not use devices in parallel in mounting orientations other than the standard mounting orientation or in any other condition, where a reduction of the output current is required.

For N+1 redundancy the ambient temperature is not allowed to exceed +45°C.

Wiring examples for 1+1 and N+1 redundancy:

Fig. 23-4 1+1 Redundant configuration for 10A load current

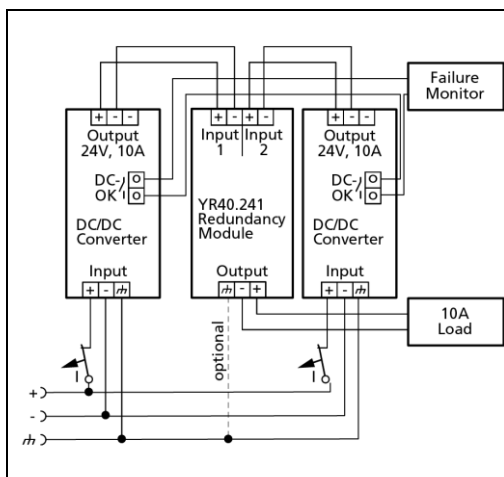
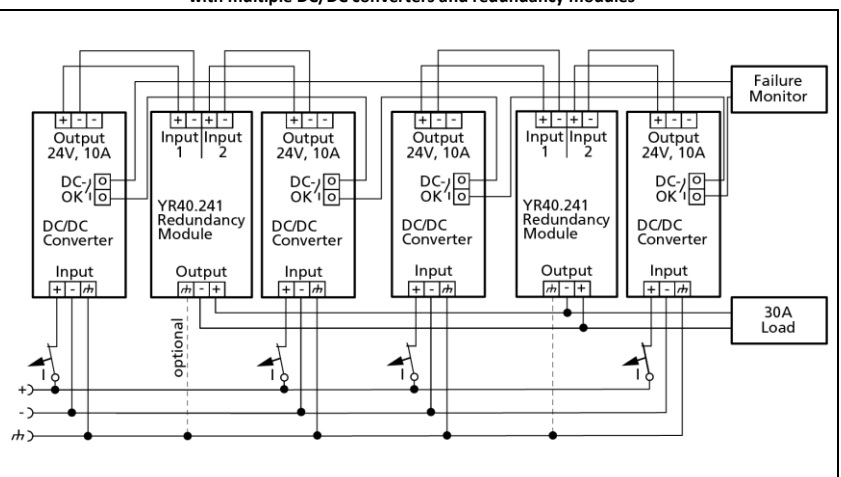

Fig. 23-5 N+1 Redundant configuration for 30A load current with multiple DC/DC converters and redundancy modules



23.7. USE IN A TIGHTLY SEALED ENCLOSURE

When the DC/DC Converter is installed in a tightly sealed enclosure, the temperature inside the enclosure will be higher than outside. In such situations, the inside temperature defines the ambient temperature for the DC/DC Converter.

The following measurement results can be used as a reference to estimate the temperature rise inside the enclosure. The DC/DC Converter is placed in the middle of the box, no other heat producing items are inside the box.

The temperature sensor inside the box is placed in the middle of the right side of the DC/DC Converter with a distance of 1cm.

	Case A	Case B
Enclosure size	110x180x165mm Rittal Typ IP66 Box PK 9516 100, plastic	110x180x165mm Rittal Typ IP66 Box PK 9516 100, plastic
Input voltage	48Vdc	48Vdc
Load	24V, 8A; (=80%)	24V, 10A; (=100%)
Temperature inside the box	45.4°C	52.4°C
Temperature outside the box	21.0°C	21.0°C
Temperature rise	24.4K	31.4K

23.8. MOUNTING ORIENTATIONS

Mounting orientations other than input terminals on the bottom and output on the top require a reduction in continuous output power or a limitation in the maximum allowed ambient temperature.

The listed lifetime and MTBF values from this datasheet apply only for the standard mounting orientation.

The following curves give an indication for allowed output currents for altitudes up to 2000m.

Fig. 23-6
Mounting
Orientation A
(Standard
orientation)

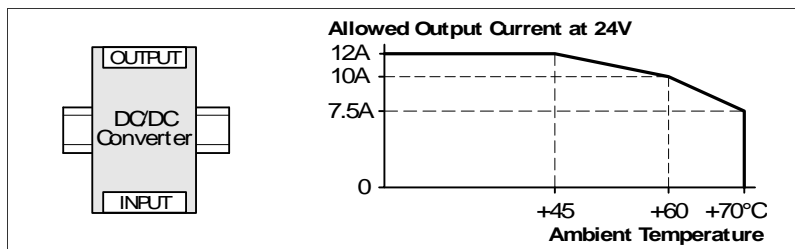

Fig. 23-7
Mounting
Orientation B
(Upside down)

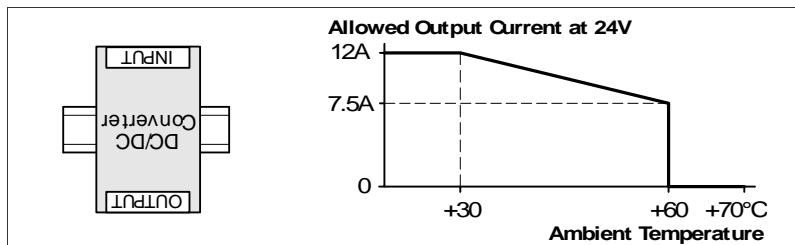

Fig. 23-8
Mounting
Orientation C
(Table-top
mounting)

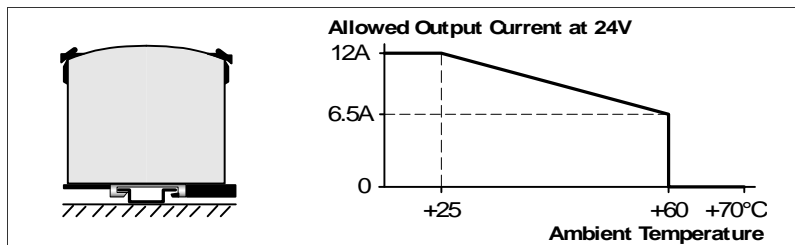

Fig. 23-9
Mounting
Orientation D
(Horizontal cw)

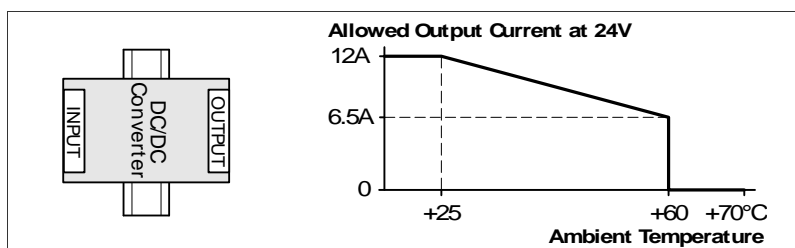

Fig. 23-10
Mounting
Orientation E
(Horizontal ccw)

