



Front Panel



User's Manual



Video



Back Panel



■ Features

- Wide input voltage range 10~60VDC / 60~420VDC by models
- High efficiency up to 91%
- Modular design for flexible configuration
- Flexible CC/CV operation modes
- Remote control and monitoring by CANBus protocol via CMU2A control console
- Maximum 64 units ERG-5000 series that can be connected
- Protections: Over voltage / Under voltage / Over temperature / Over power / Grid fault / Communication error
- 5 years warranty

■ Applications

- Battery test or power supply aging system
- Energy recycling system
- Connector mechanical test

■ GTIN CODE

MW Search: <https://www.meanwell.com/serviceGTIN.aspx>

■ Description

ERG-5000 series is an Grid Type energy recycling power inverter that supports 5KW rated and maximum up to 6KW input, It can achieve high efficiency up to 91%. CC and CV modes selectable and 4 input channels design that can be used independently or connected in series or parallel offer flexible combinations for various applications. Moreover, the ERG-5000 series also provide remote control and monitoring functions by using CMU2A or the CANBus protocol for data analysis and remote monitor. ERG-5000 supports 10~60VDC input voltage & ERG-5000H supports 60~420VDC input voltage.

■ Model Encoding

ERG - 5000 H

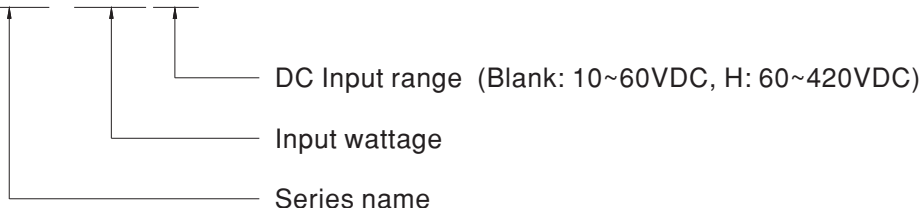

※ Note: Control / Monitor unit, CMU2 available. Details on <https://www.meanwell.com/>
Order No. CMU2A-#R#



4 Channels 5KW Energy Recycling Grid Type Power Inverter **ERG-5000** series

SPECIFICATION (Note.1)

MODEL		ERG-5000	ERG-5000H
DC INPUT	RATED INPUT POWER (Typ.)	5000W (1250W*4CH)	5000W (1250W*4CH)
	MAX. INPUT POWER (Typ.) (Note.2)	6000W (1500W*4CH)	6000W (1500W*4CH)
	INPUT VOLTAGE RANGE	10 ~ 60VDC	60 ~ 420VDC
	RATED INPUT CURRENT (Typ.)	105A*4CH	21A*4CH
	MAX. INPUT CURRENT (Typ.)	125A*4CH	25A*4CH
AC OUTPUT	RATED OUTPUT POWER (Typ.)	2600 ~ 4320VA (For input 10 ~ 12VDC) 4320 ~ 4400VA (For input 12 ~ 60VDC)	4500 ~ 4600VA (For input 60 ~ 420VDC)
	AC VOLTAGE RANGE	180 ~ 264 ± 5VAC, single phase	
	AC GRID FREQUENCY	47 ~ 63Hz	
	MAX. OUTPUT CURRENT (Typ.)	24A/230VAC	
	POWER FACTOR (AT RATED POWER)	>0.97	
	THD(AT RATED POWER) (Typ.)	<5%	
	EFFICIENCY (Typ.)	88%@48VDC input/5000W	91%@380VDC input/5000W
	ENERGY RECYCLING RATIO (Typ.)	80%@48VDC input/5000W (power supply efficiency ≥ 90.5%)	88%@380VDC input/5000W (power supply efficiency ≥ 96.5%)
PROTECTION	OVER TEMPERATURE	Shuts down AC output voltage, reset after fault condition removed	
	DC INPUT OVER VOLTAGE	Shuts down AC output voltage, reset after fault condition removed	
	DC INPUT UNDER VOLTAGE	Shuts down AC output voltage, reset after fault condition removed	
	GRID FAULT (Note.3)	Shuts down AC output voltage, reset after fault condition removed	
	COMMUNICATION ERROR	Shuts down AC output voltage after communication is failed for 4s. Reset after communication is re-built	
	OVER POWER	Constant power limiting at MAX input power	
FUNCTION	COMMUNICATION INTERFACE	CANBus, Baud Rate 250k bps (Maximum 64 units ERG-5000 series)	
	CC/CV MODE SELECT (Note.4)	CONSTANT CURRENT (CC) : 0.5~125A(±1%) / per. channel	CONSTANT CURRENT (CC) : 0.1~25A(±1%) / per. channel
		CONSTANT VOLTAGE (CV) : 10~60VDC (±1%)	CONSTANT VOLTAGE (CV) : 60~420VDC (±1%)
	PARALLEL	Please refer to function manual and user manual for more detail	
ENVIRONMENT	WORKING TEMP.	-20 ~ +60°C	
	WORKING HUMIDITY	20% ~ 90% RH non-condensing	
	STORAGE TEMP., HUMIDITY	-40 ~ +85°C, 10 ~ 95% RH	
	VIBRATION	10 ~ 500Hz, 2G 10min./1cycle, 60min. each along X, Y, Z axes	
SAFETY & EMC (Note 6)	SAFETY STANDARDS	BS EN/EN62368-1 approved	
	WITHSTAND VOLTAGE	I/P-O/P:4KVDC I/P-FG:2.5KVDC O/P-FG:2.5KVDC	I/P-O/P:2.5KVDC I/P-FG:2.5KVDC O/P-FG:2.5KVDC
	EMC EMISSION	Note.5 Compliance to BS EN/EN55032 (CISPR32) Class A	
	EMC IMMUNITY	Note.5 Compliance to BS EN/EN55035, BS EN/EN61000-4-2,3,4,5,6 light industry level, criteria A	
OTHERS	MTBF	ERG-5000: 148.8K hrs min. Telcordia SR-332 (Bellcore) ; 15K hrs min. MIL-HDBK-217F (25°C)	ERG-5000H: 172K hrs min. Telcordia SR-332 (Bellcore) ; 19.5K hrs min. MIL-HDBK-217F (25°C)
	COOLING	Internal fan cooling	
	DIMENSION	504*211*83.5mm(L*W*H)	
	PACKING	12Kg; 1pcs/12Kg/0.86CUFT	
NOTE	<p>1.All parameters NOT specially mentioned are measured at 230VAC output,48VDC input (ERG-5000),380VDC input(ERG-5000H),rated input power and 25°C of ambient temperature.</p> <p>2.It achieves max input power up to 6000W, auto derating to rated power by ambient temperature increasing , OTP occurs when the internal temperature exceeds the limit.</p> <p>3.Grid Fault:Includes AC output over voltage protection and under voltage protection.</p> <p>4.Tolerances are calculated based on MAX input current and MAX input voltage. Tolerances may increase during high and low ambient temperature operation.</p> <p>5.Guidance of additional filter, please refer to user manual for more detail.</p> <p>6.The power supply is considered a component which will be installed into a final equipment. All the EMC tests are been executed by mounting the unit on a 900mm*1300mm metal plate with 2mm of thickness. The final equipment must be re-confirmed that it still meets EMC directives. For guidance on how to perform these EMC tests, please refer to "EMI testing of component power supplies." (as available on http://www.meanwell.com)</p> <p>※ Product Liability Disclaimer : For detailed information, please refer to https://www.meanwell.com/serviceDisclaimer.aspx</p>		

Block Diagram

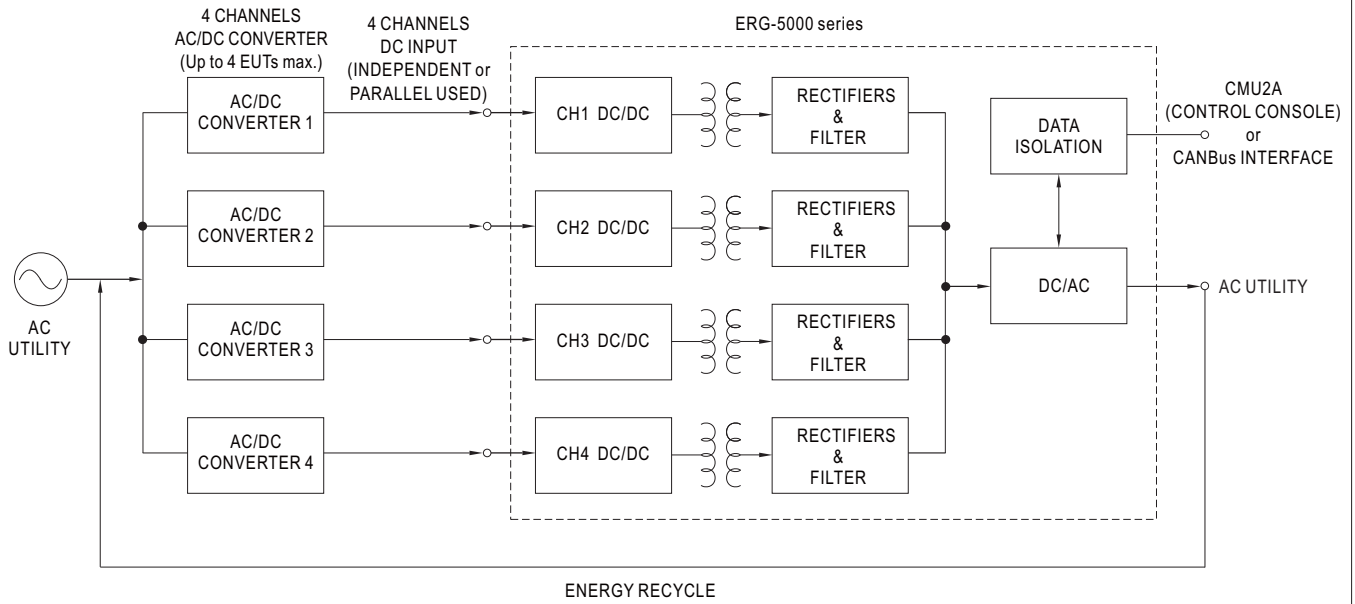

EFFICIENCY vs LOAD

※ ERG-5000 model
Efficiency measured at 48VDC input and 25°C of ambient temperature

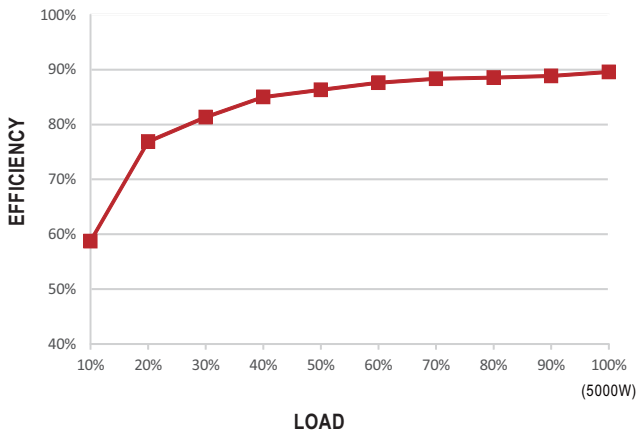

※ ERG-5000H model
Efficiency measured at 380VDC input and 25°C of ambient temperature

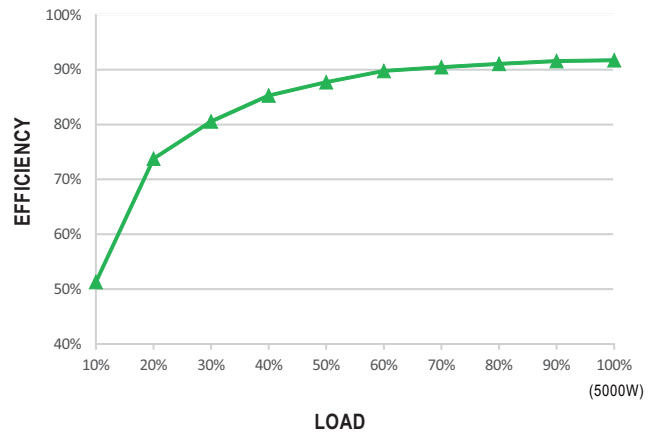

Energy Recycling Ratio Calculation

※ Energy recycling ratio = Efficiency 1 (power supply) x Efficiency 2 (ERG-5000 series)

Static Characteristics

※ ERG-5000 model

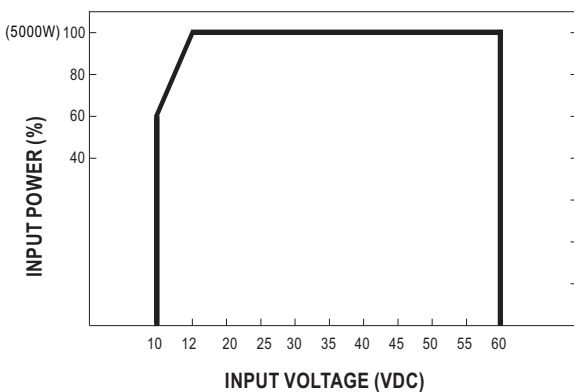

※ ERG-5000H model

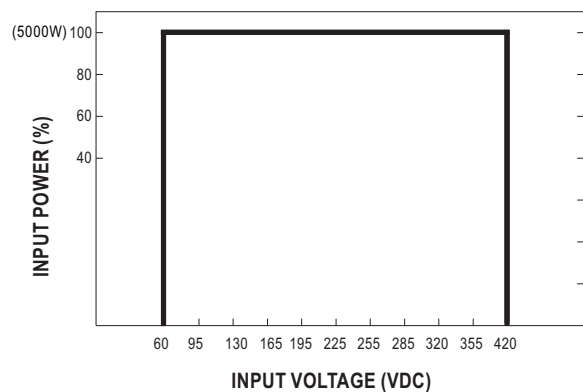

Mechanical Specification

Case No. 223F Unit:mm

◎ ERG-5000 series

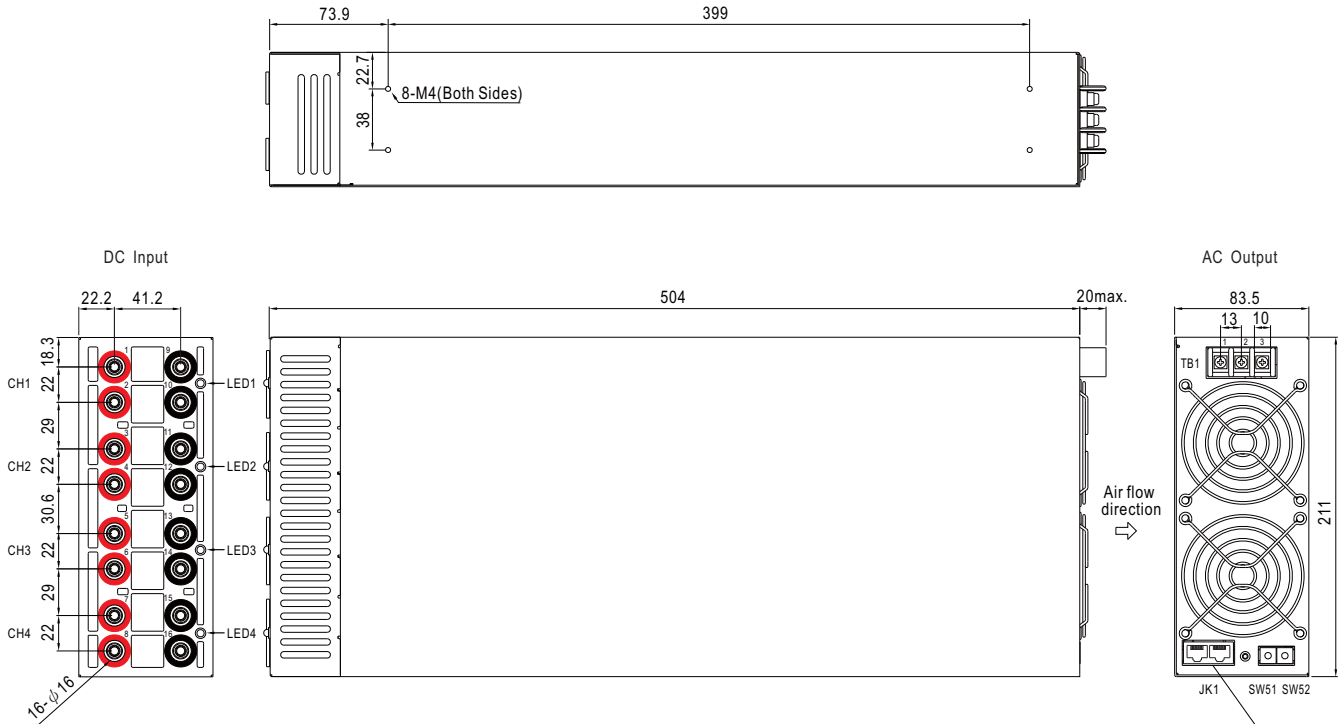

※ JK1 Pin No. Assignment :

Pin No.	Function	Description
1,9	CANH	Data line used in CANBus interface
2,10	CANL	Data line used in CANBus interface
3,11	NC	Retain for future use
4,12	FG	Reference ground for CANBus interface
5,6,7,8,13 14,15,16	NC	Not use

※ SW51 and SW52 S.W

For CANBus interface address setting, please refer to the user manual for more details

※ LED1~4 Status Indicators

LED	Description
● LED OFF	No AC utility connected
● Steady Green	Normal operating
⚡ Flashing Green	Abnormal status (OTP, Grid Fault)
● Steady Orange	Standby mode
⚡ Flashing Orange	Internal communication error
● Steady Red	Input UVP
⚡ Flashing Red	Input OVP

※ TB1 Pin No. Assignment :

Pin No.	Function	Description	Diagram	Maximum mounting torque
1	L	AC/L		8Kgf-cm
2	N	AC/N		
3	FG	Protective earthing		

※ DC Input Pin No. Assignment : PRO-TEN 5.7mm NEWSOK PCB mount assembly or equivalent

Pin No.	Function	Description	Mating Housing
1~8	+V	Positive end of DC input CH1: PIN1 & 2, CH2: PIN3 & 4, CH3: PIN5 & 6, CH4: PIN7 & 8	PRO-TEN 5.7mm NEWSOK SURLOK PIN or equivalent
9~16	-V	Negative end of DC input CH1: PIN9 & 10, CH2: PIN11 & 12, CH3: PIN13 & 14, CH4: PIN15 & 16	PRO-TEN 5.7mm NEWSOK SURLOK PIN or equivalent

Function Manual

1. Energy Recycle Burn-in System Diagram

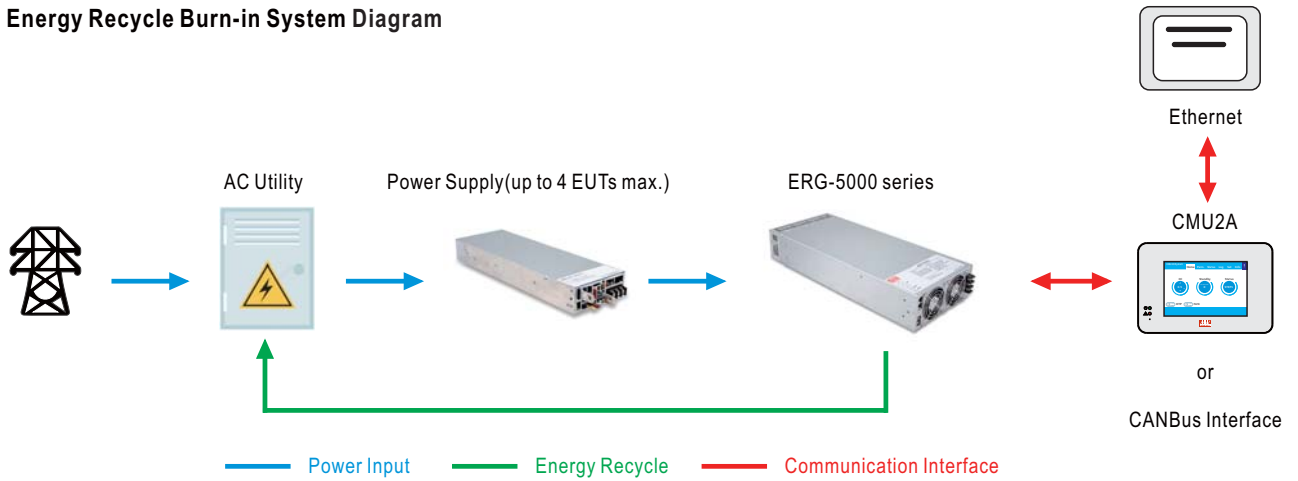

2. Front Panel Connection Diagram

Note : Select suitable wires for connection between the power supply(EUTs) and the ERG-5000 series to reduce line loss and increase energy recycling ratio.
(1)4 channels in parallel

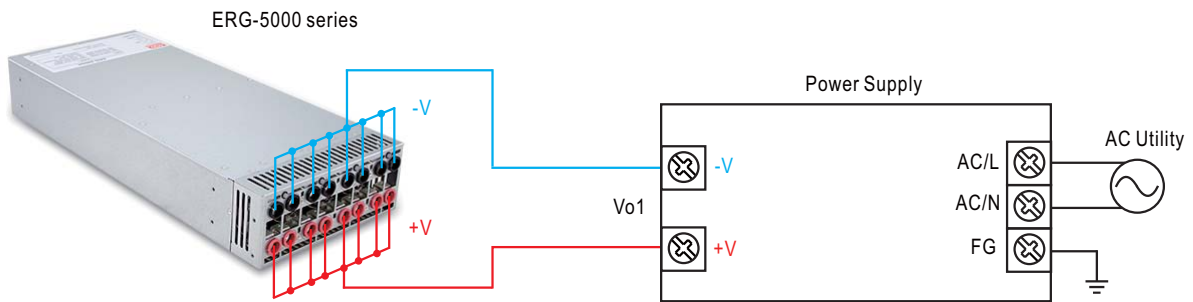

(2)2 channels independent used
Input power: (1250W*2)*2 channels independent used

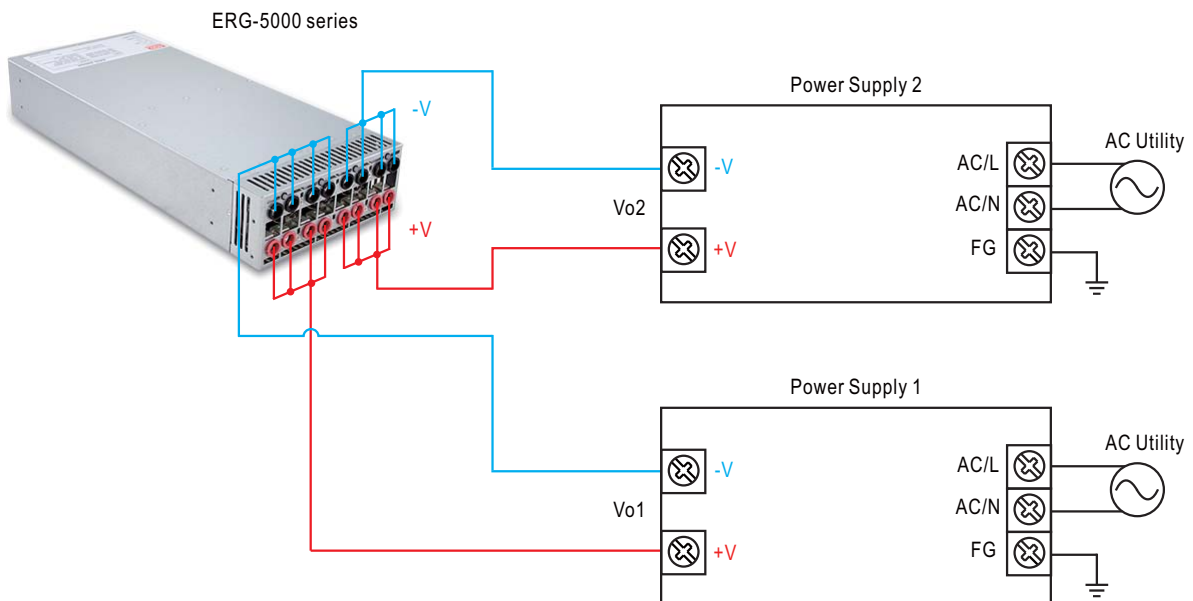

(3)4 channels independent used

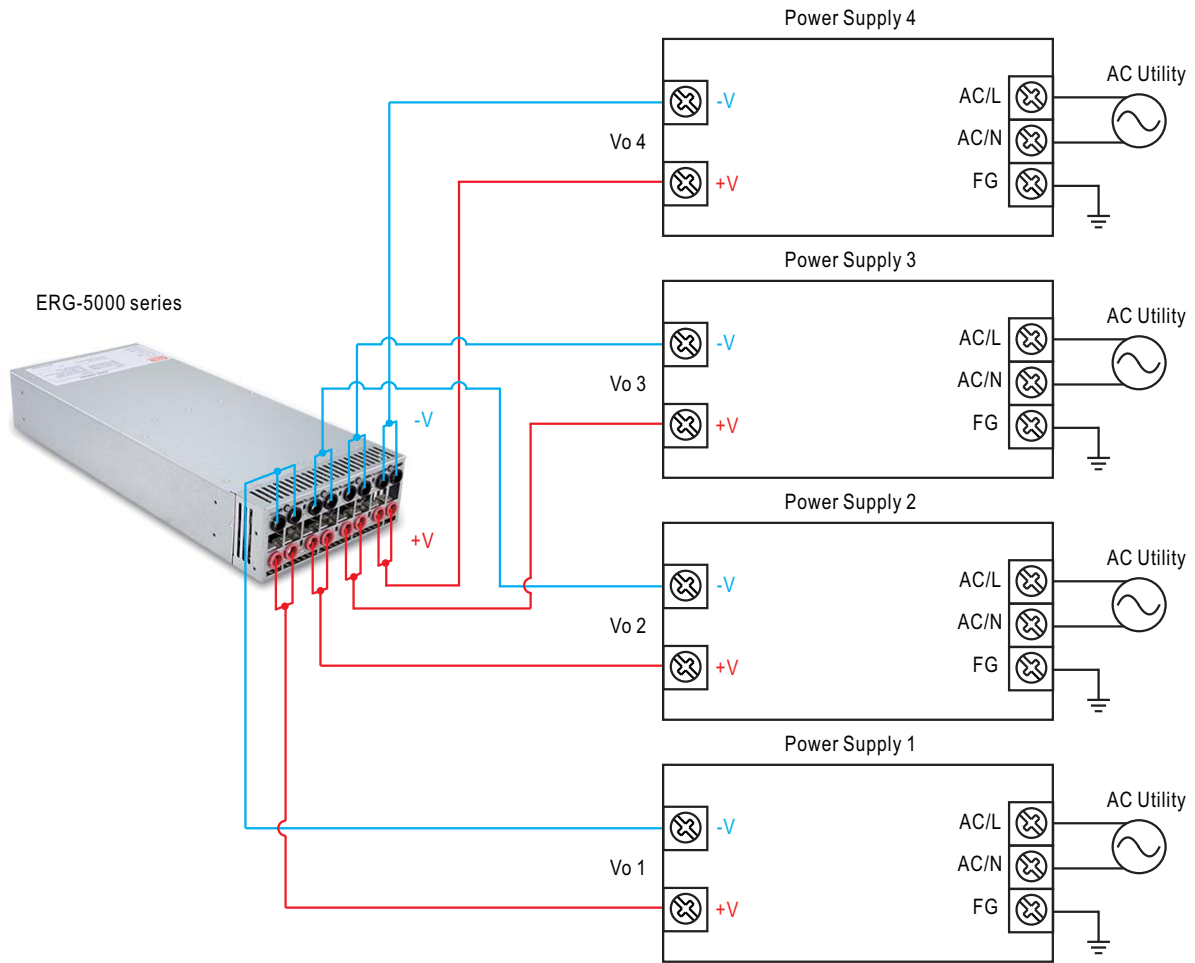

3. Back Panel Connection Diagram

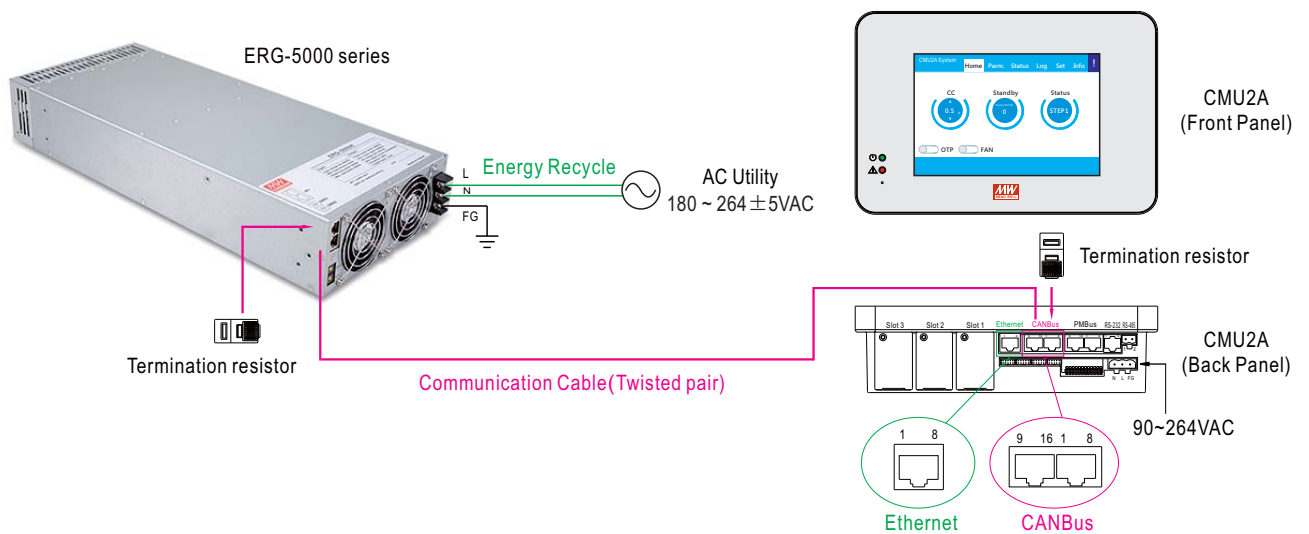

Note : After connecting the communication cable, install termination resistors to the remaining sockets of both the ERG-5000 series and CMU2A to prevent signal reflections.

■ Accessory List

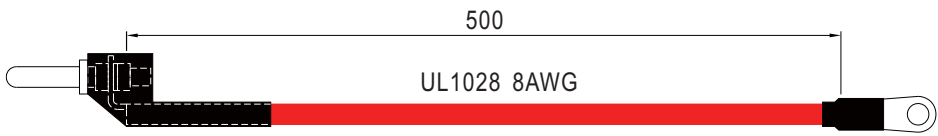
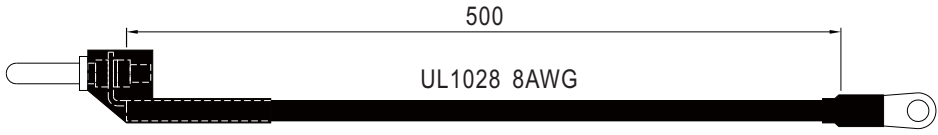
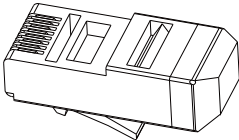
	Item	Quantity
①	<p>Red wire for +V connector</p>  <p>500</p> <p>UL1028 8AWG</p>	8
②	<p>Black wire for -V connector</p>  <p>500</p> <p>UL1028 8AWG</p>	8
③	<p>Termination resistor</p> 	1