

DC-DC CONVERTER HFBC60-W/KS

RAILWAY CONVERTER.

FOR PCB AND CHASSIS MOUNTING



HIGHLIGHTS

- + Output Power up to 60 Watts*
- + Efficiency up to 90%
- + Ultra Wide Input Range
- + Wide Temperature Range
- + Hold-up-time > 10ms
- + RoHS compliance
- + According to EN50155

INPUT

Input Voltage Nominal	24, 36, 48, 72 and 110 VDC
Input Voltage Operating	16,8-137,5 VDC
Input Voltage Range	14,4-154 VDC (t ± 1,0 sec.)
No Load Input Current	See table page 2

OUTPUT

Output Voltage	5,1 V, 12 V and 24 V (other voltages on request)
Initial Set Accuracy	< 2 % (no load)
Minimum Load	No minimum load
Short circuit	Continuous short circuit proof
Line Regulation	< 0,5 %
Load Regulation	< 2 % (0% - 100% load)
Ripple & Noise	< 2 % pk-pk, 20 MHz bandwidth
Start Time	< 900 ms
Max. Output Capacitance	500 uF x I _{out nom}
Temperature Coefficient	< 0.01 %/°C

FEATURES

Enable/Inhibit Signal	See page xx
Reverse Polarity Protection	Max. 160 V
Active Inrush Current Limitation	Max. 8 A
Hold-up-time	> 10 ms at full load
Adjust Signal	See page xx
Tracking Signal	See page xx

PROTECTION

Output Over Voltage Protection (OVP)	110-130 % V _{out nom} (latched, reset through EN or power off)
Over Current Protection (OCP)	See table page 2
Over Temperature Protection (OTP)	Shutdown at +105-110°C PCB-temp. with about 5°C hysteresis and auto recovery.

GENERAL

Product Standard	EN 50155:2007
Isolation	2200 VDC Input to Output 1500 VDC Input to Earth (PE) 710 VDC Output to Earth (PE)
Switching Frequency	Typ. 120 kHz
Dimensions [mm]	113,5 x 35 x 46
Weight	approx. 300 g
MTBF	TBD
Fire & Smoke	TBD

ENVIRONMENTAL

Operating Ambient Temp.	-40°C to +85°C*
Storage Temperature	-55°C to +100°C
Vibration / Shock / Bump	EN 61373:1999, Cat. 1B

EMC

EMC Standard	EN 50121-3-2:2006
Conducted Emissions	EN 55011:2007+A2:2007, Class B**
Radiated Emissions	EN 55011:2007+A2:2007, Class A**
ESD Immunity	EN 61000-4-2:2009, level 3 (6kV/8kV), Criteria A
Burst	EN 61000-4-4:2004, level 3 (2kV), Criteria A
Surge	EN 50121-3-2:2006, line to line ±1kV, 42R, and line to case ±2kV, 42R, Criteria A
Conducted Immunity	EN 61000-4-6:2007+A1:2001, level 3 (10V), Criteria A
Radiated Immunity	EN 61000-4-3:2006, 20V/m, Criteria A
Safety Approvals	EN 60950-1:2006+A11:2009+A1:2010+A12:2012

* +70°C continuously, +85°C max. 10 minutes at full load (baseplate temp. must not exceed +90°C).

** In built-in condition the devices may show different EMC properties.

TECHNICAL DATA

For $T_{amb} = 25^{\circ}\text{C}$, $V_{in\ nom}$, $I_{out\ nom}$, unless otherwise specified

SPECIFICATION Input 14,4 - 154 VDC

TYPE			HFBC60-W/KS				
ORDER NUMBER			87 71 08 0112 6				
CHARACTERISTIC		Unit					
INPUT	Input Voltage Nominal	V	24	36	48	72	110
	Input Voltage Range	V	14,4...36	21,6...51	28,8...67,2	43,2...101	66...154
	Under Voltage Turn-on	V	<15,0...16,8				
	Under Voltage Turn-off	V	<12,0...14,4 (14,4V < Vin < 16,8V at t > 1 sec.)				
	Input Current @ Full Load	A	3,0	2,0	1,4	0,95	0,62
	Input Current @ No Load	A	0,09	0,06	0,05	0,03	0,02
	Recommended External Fuse	A	4,0				
	OUTPUT	Output Voltage Nominal	V	5,1			
Output Current Nominal		A	12,0				
Output Power		W	60				
Efficiency @ Full Load (typical)		%	85	86	87	88	89
Output Current limit		A	13,0...18,0				
Short Circuit Current (typical)			20 (pulse approx. 3Hz)*				
Transient Response 25 % / 75 % Load Step Recovery Time < 1 ms		mV	±150				

SPECIFICATION Input 14,4 - 154 VDC

TYPE			HFBC60-W/KS				
ORDER NUMBER			87 71 12 0112 1				
CHARACTERISTIC		Unit					
INPUT	Input Voltage Nominal	V	24	36	48	72	110
	Input Voltage Range	V	14,4...36	21,6...51	28,8...67,2	43,2...101	66...154
	Under Voltage Turn-on	V	<15,0...16,8				
	Under Voltage Turn-off	V	<12,0...14,4 (14,4V < Vin < 16,8V at t > 1 sec.)				
	Input Current @ Full Load	A	3,0	2,0	1,4	0,95	0,62
	Input Current @ No Load	A	0,05	0,035	0,03	0,015	0,01
	Recommended External Fuse	A	4,0				
	OUTPUT	Output Voltage Nominal	V	12			
Output Current Nominal		A	5				
Output Power		W	60				
Efficiency @ Full Load (typical)		%	85	86	87	88	89
Output Current limit		A	5,5...8,0				
Short Circuit Current (typical)		A	10 (pulse approx. 3Hz)*				
Transient Response 25 % / 75 % Load Step Recovery Time < 1 ms		mV	±180				

SPECIFICATION Input 14,4 - 154 VDC

TYPE			HFBC60-W/KS				
ORDER NUMBER			87 71 24 0112 6				
CHARACTERISTIC		Unit					
INPUT	Input Voltage Nominal	V	24	36	48	72	110
	Input Voltage Range	V	14,4...36	21,6...51	28,8...67,2	43,2...101	66...154
	Under Voltage Turn-on	V	<15,0...16,8				
	Under Voltage Turn-off	V	<12,0...14,4 (14,4V < Vin < 16,8V at t > 1 sec.)				
	Input Current @ Full Load	A	2,9	1,9	1,3	0,9	0,6
	Input Current @ No Load	A	0,05	0,03	0,025	0,015	0,01
	Recommended External Fuse	A	4,0				
	OUTPUT	Output Voltage Nominal	V	24			
Output Current Nominal		A	2,5				
Output Power		W	60				
Efficiency @ Full Load (typical)		%	86	87	88	89	90
Output Current limit		A	2,8...3,8				
Short Circuit Current (typical)		A	5 (pulse approx. 3Hz)*				
Transient Response 25 % / 75 % Load Step Recovery Time < 1 ms		mV	±250				

TECHNICAL DATA

For $T_{amb} = 25^{\circ}\text{C}$, $V_{in\ nom}$, $I_{out\ nom}$, unless otherwise specified

MECHANICAL DETAILS

1. Dimensions are in mm
2. Unless otherwise specified, general tolerances $\pm 0,5$ are for values in brackets (XX)
Values not in brackets are according to ISO-2768-1m

Hole $\varnothing 3,5\text{mm}$, area $\varnothing 6\text{mm}$ blank
For alternative ground connection
(see notes "Installation")

HFBC60-W/Ks

Connector:
Phoenix MSTB 2,5/6-ST-5,08
Wire cross section max $2,5\text{mm}^2$

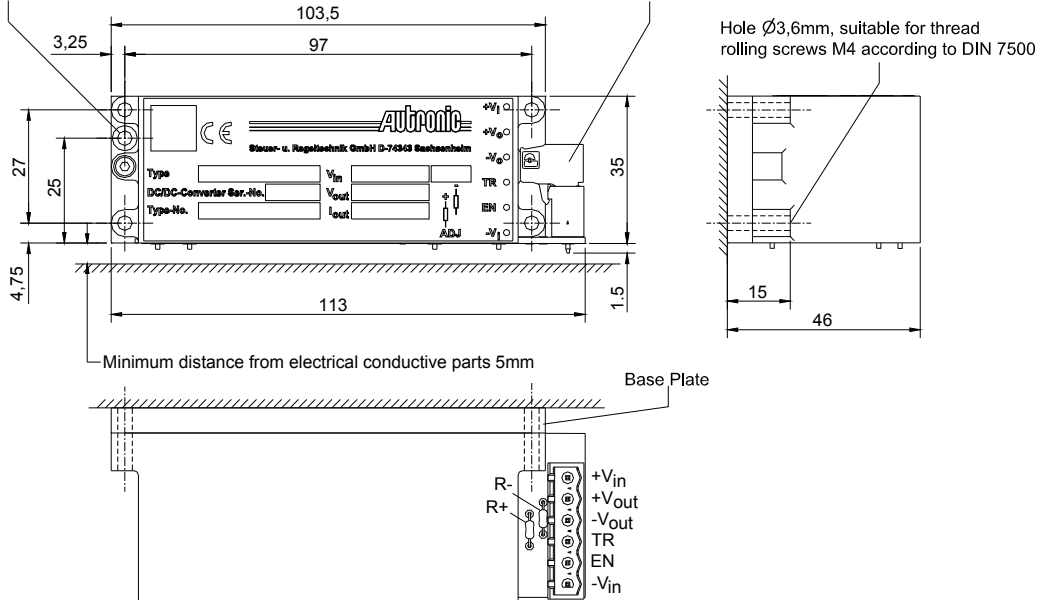

Resin compound: Polyurethane black, UL94-V0

PINNING

Pin	Function
X1	$+V_{in}$
X2	$-V_{in}$
X3	$+V_{out}$
X4	$-V_{out}$
X5	EN
X6	Track
X7	Adjust

NOTES

Installation instructions:

The converters have to be installed according to the guidelines currently in force, like other open electronic component assemblies. Attention must be paid to sufficient ventilation, carry off heat, fastening and protection against accidental contact. Plug in not under voltage if converter connected parallel or in series.

Fault protection: For input protection a time-lag fuse corresponding to IEC 60127-2 must be installed. For recommended rating of the fuse refer to specification table above. Pay attention on sufficient current source in case of short circuit.

BLOCK DIAGRAM

