



P-DUKE POWER

LSR01 Series

DC-DC Converter
Up to 15 Watts

3

YEARS
WARRANTY

ROHS
COMPLIANT

REACH
COMPLIANT



Automation



Datacom



IPC



Industry



Measurement



Telecom



Automobile



Boat



Charger



Medical



PV



Railway



NON
-isolation

LOW
Standby
Power

NO
Min. Load
Required

OCP

OTP

SCP

PART NUMBER STRUCTURE

Series Name	12 Input Voltage (VDC)	S Output Quantity	05 Output Voltage (VDC)
	05:3.0~5.5 12:4.6~36 24:12~36 * See table as below	S:Single	1P2:1.2 1P5:1.5 1P8:1.8 2P5:2.5 3P3:3.3 05:5 6P5:6.5 09:9 12:12 15:15

TECHNICAL SPECIFICATION All specifications are typical at nominal input, full load and 25°C unless otherwise noted

Model Number	Input Range	Output Voltage	Output Current @ Full Load	Input Current @ No Load	Efficiency		Maximum Capacitor Load
	VDC	VDC	A	mA	%		µF
					Min. Vin	Max. Vin	
LSR01-05S1P2	3.0 ~ 5.5	1.2			90.5	90.0	
LSR01-05S1P5	3.0 ~ 5.5	1.5			92.0	91.5	
LSR01-05S1P8	3.0 ~ 5.5	1.8			92.5	92.0	
LSR01-05S2P5	3.8 ~ 5.5	2.5			94.5	94.0	
LSR01-12S1P2	4.6 ~ 36	1.2			74	62	
LSR01-12S1P5	4.6 ~ 36	1.5			79	67	
LSR01-12S1P8	4.6 ~ 36	1.8			82	70	
LSR01-12S2P5	4.6 ~ 36	2.5	1	1	87	75	470
LSR01-12S3P3	4.75 ~ 36	3.3			91	80	
LSR01-12S05	6.5 ~ 36	5.0			94	84	
LSR01-12S6P5	9.0 ~ 36	6.5			94	89	
LSR01-24S09	12 ~ 36	9.0			95	90	
LSR01-24S12	15 ~ 36	12			95	92	
LSR01-24S15	18 ~ 36	15			96	94	

INPUT SPECIFICATIONS							
Parameter	Conditions			Min.	Typ.	Max.	Unit
Operating input voltage range	LSR01-05S1P2			3.0	5.0	5.5	VDC
	LSR01-05S1P5			3.0	5.0	5.5	
	LSR01-05S1P8			3.0	5.0	5.5	
	LSR01-05S2P5			3.8	5.0	5.5	
	LSR01-12S1P2			4.6	12	36	
	LSR01-12S1P5			4.6	12	36	
	LSR01-12S1P8			4.6	12	36	
	LSR01-12S2P5			4.6	12	36	
	LSR01-12S3P3			4.75	12	36	
	LSR01-12S05			6.5	12	36	
	LSR01-12S6P5			9.0	12	36	
	LSR01-24S09			12	24	36	
	LSR01-24S12			15	24	36	
	LSR01-24S15			18	24	36	
	*With a C1 (22µF/50V) input capacitor for input voltage > 32VDC, the input voltage allows 36 VDC, max.						
Start up time	Constant resistive load	Power up	5		ms		
Input filter	Capacitor type						

OUTPUT SPECIFICATIONS

Parameter	Conditions	Min.	Typ.	Max.	Unit
Voltage accuracy		-2.0		+2.0	%
Line regulation	Low Line to High Line at Full Load	-0.2		+0.2	%
Load regulation	No Load to Full Load 10% to 90% of Full load	-0.6		+0.6	%
Ripple and noise	Measured by 20MHz bandwidth Vout ≤ 8.0V Vout > 8.0V		50 75		mVp-p
Temperature coefficient		-0.015		+0.015	%/°C
Dynamic load response	50% load step change Peak deviation Recovery time		200 250		mV μs
Over load protection	% of Iout rated; Continuous mode LSR01-05S□□ Others		4.8 2.5		A
Short circuit protection		Continuous, automatic recovery			

GENERAL SPECIFICATIONS

Parameter	Conditions	Min.	Typ.	Max.	Unit
Switching frequency	LSR01-05S□□ Others		1200 500		kHz kHz
Safety meets		IEC /UL/ EN60950-1			
Case material		Non-conductive black plastic			
Base material		Non-conductive black plastic			
Weight		1.7g(0.060oz)			
MTBF	MIL-HDBK-217F Full load	1.226 x 10 ⁷ hrs			

ENVIRONMENTAL SPECIFICATIONS

Parameter	Conditions	Min.	Typ.	Max.	Unit
Operating ambient temperature	With derating	-40		+105	°C
Maximum case temperature				+105	°C
Over temperature protection	Internal IC junction		+150		°C
Storage temperature range		-55		+125	°C
Lead-free reflow solder process		IPC J-STD-020D			
Moisture sensitivity level(MSL)		IPC J-STD-033B Level 1			
Thermal shock		MIL-STD-810F			
Vibration		MIL-STD-810F			
Relative humidity		5% to 95% RH			

CAUTION: This power module is not internally fused. An input line fuse must always be used.

CHARACTERISTIC CURVE

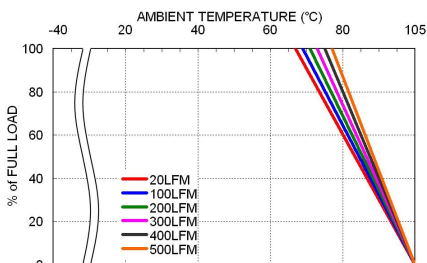

LSR01-12S05 Derating Curve

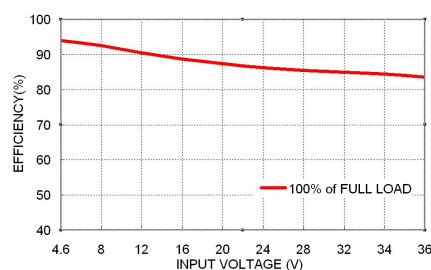

LSR01-12S05 Efficiency vs. Input Voltage

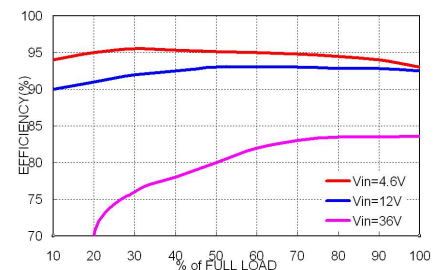

LSR01-12S05 Efficiency vs. Output Load

FUSE CONSIDERATION

This power module is not internally fused. An input line fuse must always be used.

This encapsulated power module can be used in a wide variety of applications, ranging from simple stand-alone operation to an integrated part of sophisticated power architecture.

To maximum flexibility, internal fusing is not included; however, to achieve maximum safety and system protection, always use an input line fuse.

The input line fuse suggest as below :

Model	Fuse Rating (A)	Fuse Type
LSR01-05S□□	1	Slow-Blow
LSR01-12S1P2、12S1P5、12S1P8	0.8	Slow-Blow
LSR01-12S2P5、12S3P3、12S05、12S6P5	1.25	Slow-Blow
LSR01-24S□□	1.6	Slow-Blow

The table based on the information provided in this data sheet on inrush energy and maximum DC input current at low Vin.

MECHANICAL DRAWING

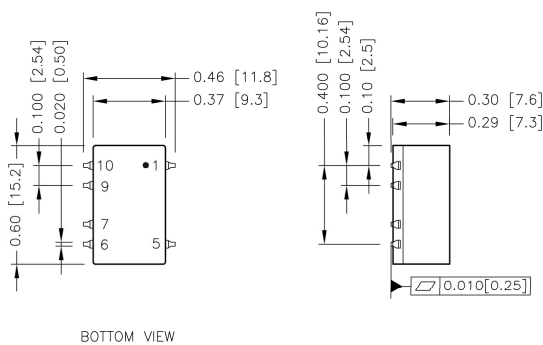

BOTTOM VIEW

PIN CONNECTION

PIN	DEFINE
1	+Vin
5	+Vout
6	NC
7	GND
9	GND
10	NC

1. All dimensions in inch [mm]
2. Tolerance :x.xx±0.02 [x.x±0.5]
x.xxx±0.01 [x.xx±0.25]
3. Pin pitch tolerance ±0.01 [0.25]
4. Pin dimension tolerance ±0.004[0.10]

RECOMMENDED PAD LAYOUT

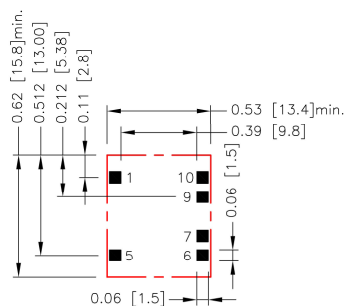

All dimensions in inch[mm]
Pad size(lead free recommended)
Top view pad:0.060x0.060[1.50x1.50]

THERMAL CONSIDERATIONS

The power module operates in a variety of thermal environments.

However, sufficient cooling should be provided to help ensure reliable operation of the unit.

Heat is removed by conduction, convection, and radiation to the surrounding Environment.

Proper cooling can be verified by measuring the point as the figure below.

The temperature at this location should not exceed 105°C.

When Operating, adequate cooling must be provided to maintain the test point temperature at or below 105°C.

Although the maximum point Temperature of the power modules is 105°C, you can limit this Temperature to a lower value for extremely high reliability.

The unit will shutdown if the internal IC junction exceeds 150°C (typical), but the thermal shutdown is not intended as a guarantee that the unit will survive temperature beyond its rating. The module will automatically restarts after it cools down.

- Thermal test condition with vertical direction by natural convection (20LFM).

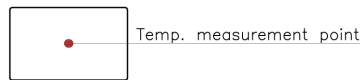

TOP VIEW