



P-DUKE POWER

MAF150 Series

2 X 4 Inch AC-DC POWER SUPPLIES
Up to 150 Watts

5
YEARS
WARRANTY

ROHS
COMPLIANT

REACH
COMPLIANT



Medical



Automation



Datacom



IPC



Industry



Measurement



Telecom



Automobile



Boat



Charger



PV



Railway



2
x
MOPP

4000
VAC
Reinforced
Insulation

ADJ.
Output
Voltage

Internal
EN55032
Class
Filter **B**

LOW
Leakage
Current

LOW
Standby
Power

Protection
Class I
Class II

Operating
Altitude
5000
meter

OCP

OVP

SCP

PART NUMBER STRUCTURE

M	A	F	150	U	S	12	B	-	□ □
Application	Package Code	Dimension Code	Output Power (W)	Input Voltage (VAC)	Output Quantity	Output Voltage (VDC)	Protection Type		Option
Medical Application	A:Open type U:U chassis type E:Enclosed type D:Din rail type			U: Universal 85 ~ 264VAC	S:Single	12:12V 15:15V 18:18V 24:24V 28:28V 36:36V 48:48V	B:CLASS II Blank:CLASS I		First Code Blank:JST M:Molex T:Terminal block Second Code F:External FAN (for MEF/ MDF)

TECHNICAL SPECIFICATION All specifications are typical at 230VAC input, full load and 25°C unless otherwise noted

Model Number	Input Range VAC	Output Voltage VDC	Output Current		Efficiency %	Maximum Capacitor Load μF
			Natural convection A	Forced air cooling With 10CFM / Option with Fan A		
MAF150US12B	85 ~ 264	12	8.34	12.5	91	10400
MUF150US12B			8.34			
MEF150US12B			10.84			
MDF150US12B			10.84			
MAF150US15B	85 ~ 264	15	7.34	10	92	6600
MUF150US15B			7.34			
MEF150US15B			9			
MDF150US15B			9			
MAF150US18B	85 ~ 264	18	6.12	8.34	92	4600
MUF150US18B			6.12			
MEF150US18B			7.5			
MDF150US18B			7.5			
MAF150US24B	85 ~ 264	24	4.59	6.25	92	2600
MUF150US24B			4.59			
MEF150US24B			5.63			
MDF150US24B			5.63			
MAF150US28B	85 ~ 264	28	3.93	5.36	92	1900
MUF150US28B			3.93			
MEF150US28B			4.83			
MDF150US28B			4.83			
MAF150US36B	85 ~ 264	36	3.06	4.17	92	1150
MUF150US36B			3.06			
MEF150US36B			3.75			
MDF150US36B			3.75			
MAF150US48B	85 ~ 264	48	2.09	3.13	92	650
MUF150US48B			2.09			
MEF150US48B			2.71			
MDF150US48B			2.71			

INPUT SPECIFICATIONS						
Parameter	Conditions		Min.	Typ.	Max.	Unit
Operating input voltage range	AC input		85		264	VAC
	DC input		120		370	VDC
Input frequency	AC input		47		63	Hz
Input current	115VAC and Full Load				1.7	A
	230VAC and Full Load				0.8	
No load input power	230VAC	Option -F (With Fan)		0.6		Watts
	230VAC	Others			0.3	
	264VAC				100	
Leakage current	264VAC				100	μA
Power Factor			0.95			
Start up time					1000	ms
Rise time				20		ms
Hold up time	115VAC and Full Load		16			ms
Input inrush current	230VAC				60	A
Input protection	Internal fuse in line and neutral				T3.15A/250VAC	

OUTPUT SPECIFICATIONS

Parameter	Conditions	Min.	Typ.	Max.	Unit
Output power	Forced air cooling with 10CFM or Option -F Natural convection for 15Vout, 18Vout, 24Vout, 28Vout, 36Vout Natural convection for 12Vout, 48Vout			150 110 100	Watts
Initial set voltage accuracy	230VAC and Full Load	-1.0		+1.0	%
Line regulation	Low Line to High Line at Full Load	-0.2		+0.2	%
Load regulation	No Load to Full Load 10% Load to 90% Load	-0.5 -0.4		+0.5 +0.4	%
Voltage adjustability		-10		+10	%
Minimum load			0		%
Ripple and noise	Measured by 20MHz bandwidth With a 1 μ F/25V 1206 X7R MLCC 12Vout 15Vout 18Vout With a 1 μ F/50V 1206 X7R MLCC 24Vout 28Vout 36Vout With a 0.1 μ F/100V 1206 X7R MLCC 48Vout		120 150 180 220 220 250 250		mVp-p
Temperature coefficient		-0.02		+0.02	%/°C
Transient response	Load step from 50 ~ 75% change at 2.5A/ μ s Peak deviation Recovery time		500	3	% Vout μ s
Over voltage protection	% of Vout(nom); Latch mode	115		135	%
Over load protection	% of Iout rated; Hiccup mode	115		150	%
Short circuit protection		Continuous, automatic recovery			
Fan power supply					12V at 500mA

GENERAL SPECIFICATIONS

Parameter	Conditions	Min.	Typ.	Max.	Unit
Isolation voltage	1 minute (2MOPP insulation) Input to Output Input (Output) to F.G.	4000 2000			VAC
Isolation resistance	500VDC	0.1			G Ω
Switching frequency			60		kHz
Safety approvals	IEC/ EN/ ANSI/AAMI ES 60601-1 IEC/ EN/ UL 60950-1			UL:E360199 UL:E193009 CB:UL(Demko)	
Weight	MAF MUF MEF MDF			187g (6.60oz) 235g (8.29oz) 256g (9.03oz) 278g (9.81oz)	
MTBF	MIL-HDBK-217F Ta=25°C, Full load			7.861 x 10 ⁵	hrs

ENVIRONMENTAL SPECIFICATIONS

Parameter	Conditions	Min.	Typ.	Max.	Unit
Operating ambient temperature	With derating Option -F (With Fan) Others	-25 -25		+80 +85	°C
Storage temperature range	Option -F (With Fan) Others	-40 -40		+75 +85	°C
Operating altitude				5000	m
Shock				IEC60068-2-27	
Vibration				IEC60068-2-6	
Relative humidity	Non-condensing			5% to 95%	RH

EMC SPECIFICATIONS

Parameter	Conditions	Level	
EMI	EN55011, EN55032, EN60601-1-2 and FCC Part 18 / 15 External components may be required for class I application.	Conducted Radiated	Class B Class A
Harmonic currents	EN61000-3-2 Full Load		Class A and D
Voltage flicker	EN61000-3-3		

EMC SPECIFICATIONS (CONTINUED)

Parameter	Conditions	Level
EMS	EN55024 and EN60601-1-2	
ESD	EN61000-4-2 Air $\pm 15\text{kV}$ and Contact $\pm 8\text{kV}$	Perf. Criteria A
Radiated immunity	EN61000-4-3 20 V/m	Perf. Criteria A
Fast transient	EN61000-4-4 $\pm 2\text{kV}$	Perf. Criteria A
Surge	EN61000-4-5 DM $\pm 1\text{kV}$ and CM $\pm 2\text{kV}$	Perf. Criteria A
Conducted immunity	EN61000-4-6 20 Vr.m.s	Perf. Criteria A
Power frequency magnetic field	EN61000-4-8 10 A/m	Perf. Criteria A
Dip and interruptions	EN61000-4-11	

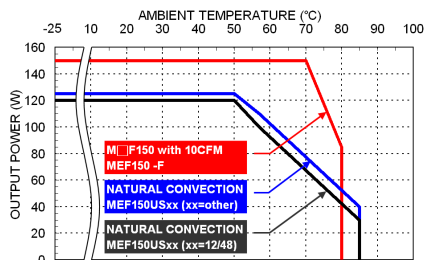
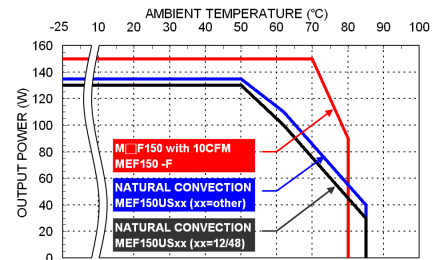
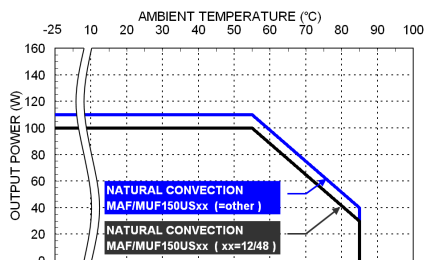
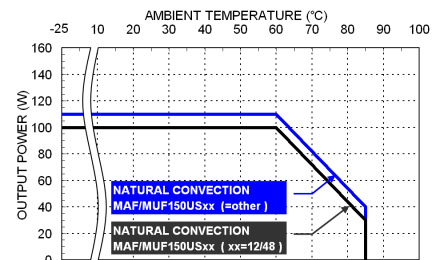
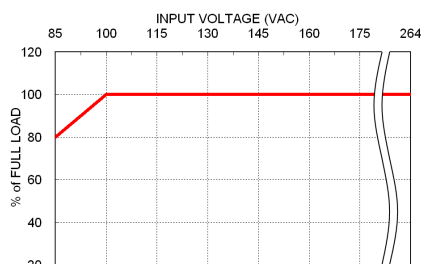
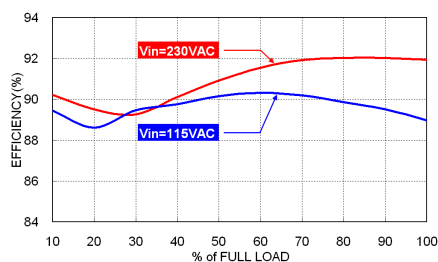
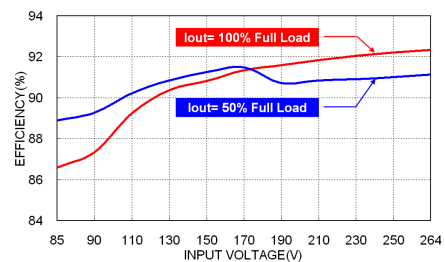
CHARACTERISTIC CURVE

 Derating Curve vs. Ambient Temperature
 $V_{in}=115\text{VAC}$

 Derating Curve vs. Ambient Temperature
 $V_{in}=230\text{VAC}$

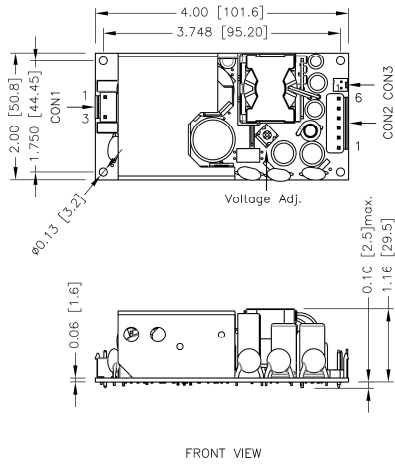
 Derating Curve vs. Ambient Temperature
 $V_{in}=115\text{VAC}$

 Derating Curve vs. Ambient Temperature
 $V_{in}=230\text{VAC}$

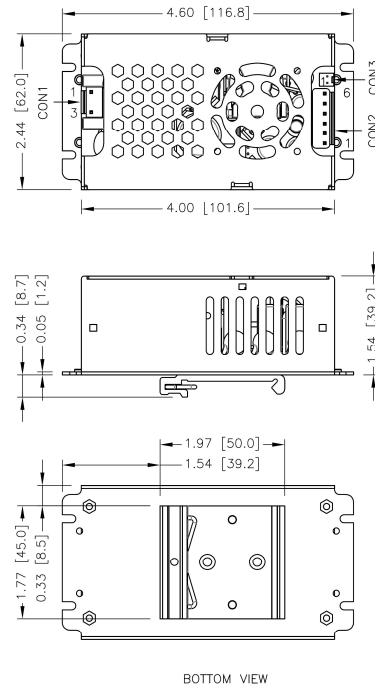
 Derating Curve vs. Input Voltage
 M/F150

 Efficiency vs. Output Load
 M/F150US24B

 Efficiency vs. Input Voltage
 M/F150US24B

MECHANICAL DRAWING

MAF Open type



MDF Din rail type



CONNECTORS CONNECTIONS

CON1 – Input Connector

Pin 1	Line
Pin 3	Neutral

CON2 – Output Connector

Pin 1,2,3	-Vout
Pin 4,5,6	+Vout

CON3 – Fan Connector

Pin 1	-Fan
Pin 2	+Fan

Mates with
Molex housing : **22-01-1022**
Molex crimp terminals : **2759**

*Either one of four screws holes of Open / Chassis type can be considered as PE connection for CLASS I application.

MECHANICAL DRAWING(CONTINUED)

MEF Enclosed type

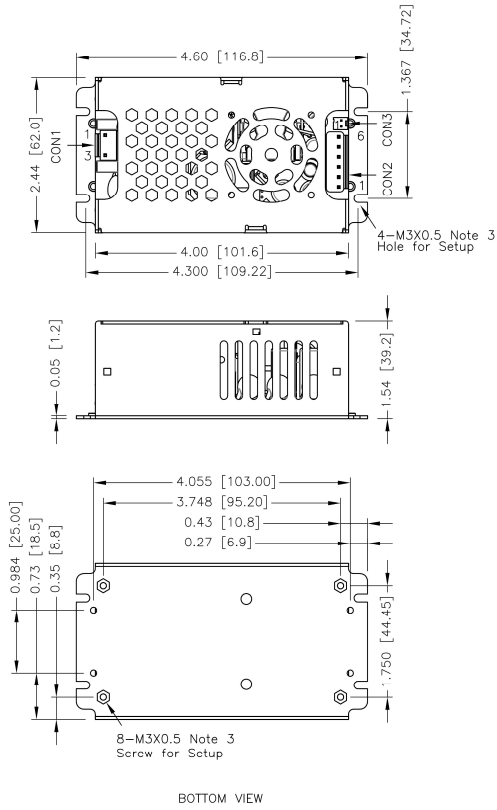

MUF U chassis type

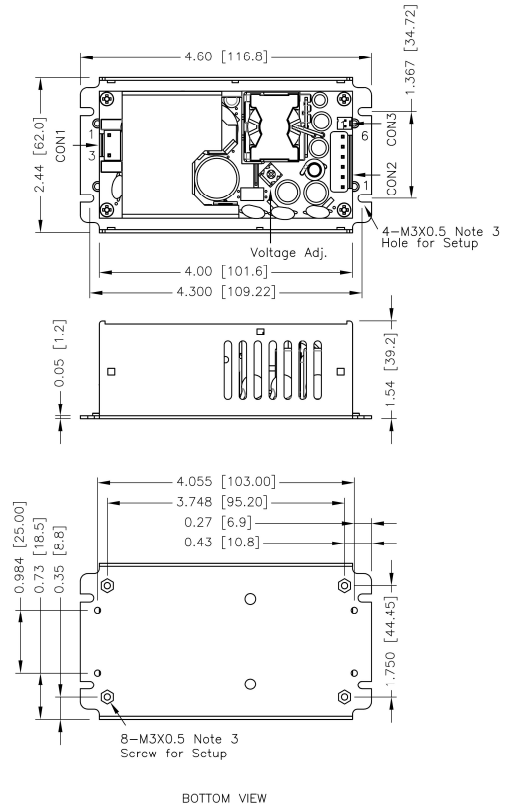

1. All dimensions in inch [mm]
2. Tolerance : x.xx±0.02 [x.x±0.5] x.xxx±0.01 [x.xx±0.25]
3. M3×0.5 screw locked torque MAX 5Kgf.cm/0.49N.m

CONNECTORS CONNECTIONS

CON1 – Input Connector

Pin 1	Line
Pin 3	Neutral

CON2 – Output Connector

Pin 1,2,3	-Vout
Pin 4,5,6	+Vout

CON3 – Fan Connector

Pin 1	-Fan
Pin 2	+Fan

Mates with
Molex housing : 22-01-1022
Molex crimp terminals : 2759

*Either one of four screws holes of Open / Chassis type can be considered as PE connection for CLASS I application.

MECHANICAL DRAWING (CONTINUED)

MEF -E Enclosed type with FAN

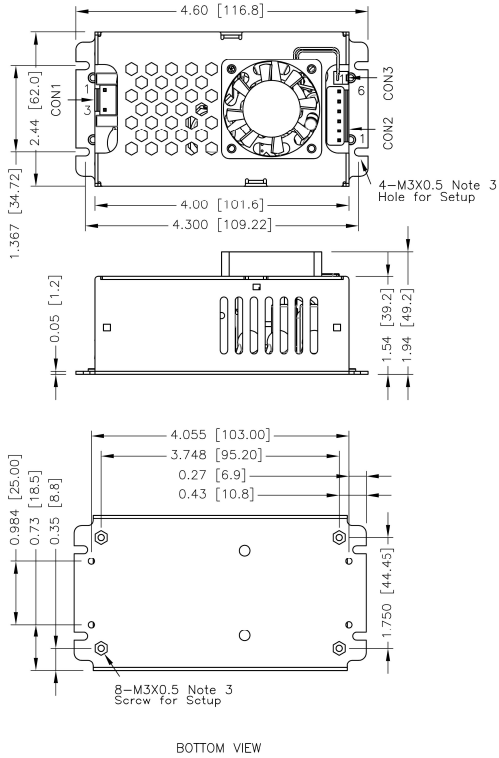

MDF -E Din rail type with FAN

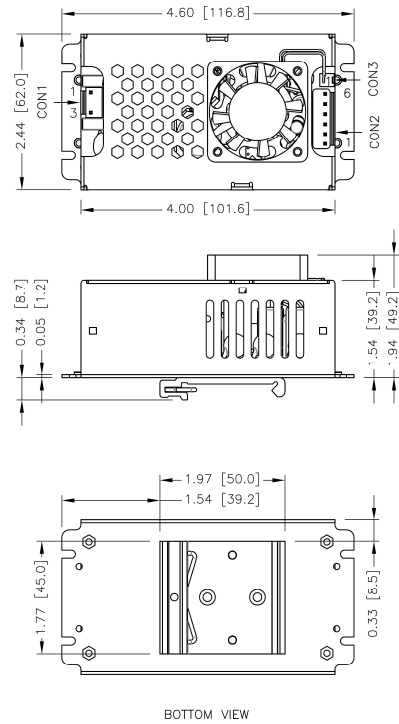

1. All dimensions in inch [mm]
2. Tolerance : x.xx±0.02 [x.x±0.5] x.xxx±0.01 [x.xx±0.25]
3. M3×0.5 screw locked torque MAX 5Kgf.cm/0.49N.m

CONNECTORS CONNECTIONS

CON1 – Input Connector

Pin 1	Line
Pin 3	Neutral

CON2 – Output Connector

Pin 1,2,3	-Vout
Pin 4,5,6	+Vout

CON3 – Fan Connector

Pin 1	-Fan
Pin 2	+Fan

Mates with
Molex housing : **22-01-1022**
Molex crimp terminals : **2759**

*Either one of four screws holes of Open / Chassis type can be considered as PE connection for CLASS I application.

CONNECTOR OPTIONS

Blank:

JST Type

Mates with housing
CON1: VHR-3N
CON2: VHR-6N



Crimp terminals
CON1: SVH-21T-P1.1
CON2: SVH-21T-P1.1

-M

Molex Type

Mates with housing
CON1: 09-50-8031
CON2: 09-50-8041



Crimp terminals
CON1: SD-2478
CON2: SD-2478

-T

Terminal Block

Screw locked torque
MAX 2Kgf.cm/0.2N.m



Wire dimension range
26 ~ 16AWG

EXTERNAL FAN OPTION

There is an external fan option for MEF and MDF. The fan's life is shorter than power supply and has only 2 years warranty. Here are specifications for replacement.

Fan dimensions	40 x 40 x 10 mm
Air flow	7 CFM

