

## ModuLED Optics Adaptor v2 for Reflector & Lens connection

### Drawings & Dimensions

#### ModuLED Mega optics adaptor v2

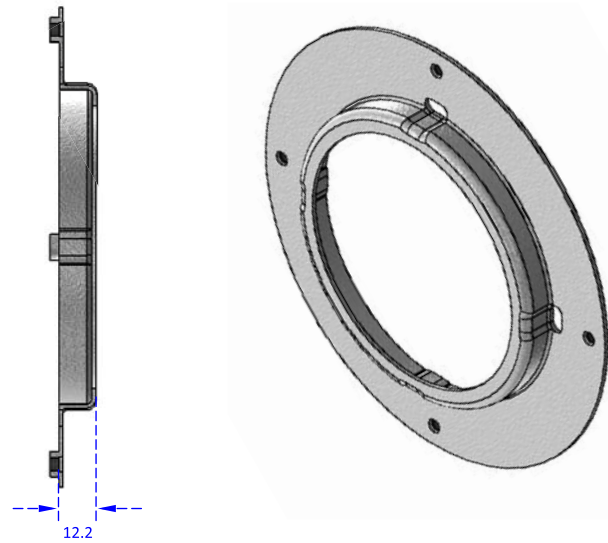
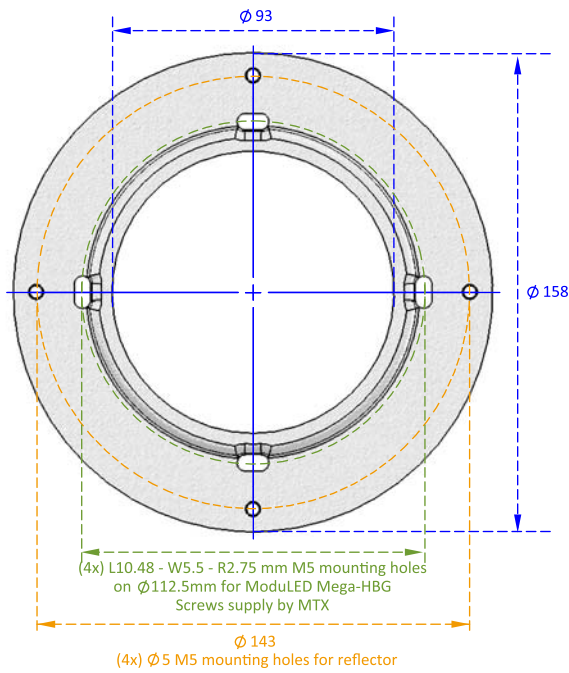

#### ModuLED Giga optics adaptor v2

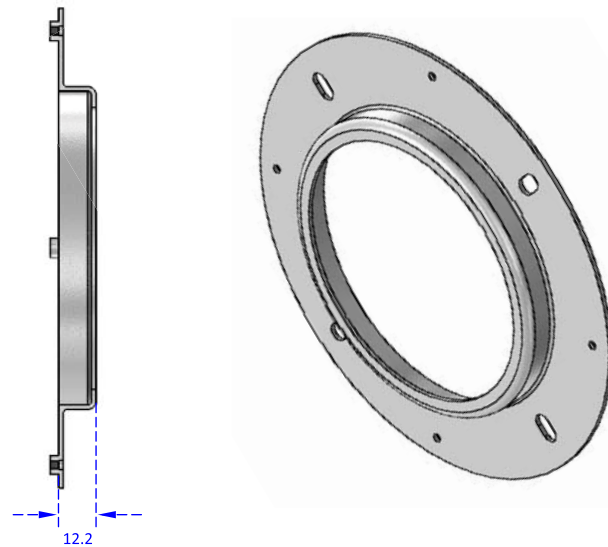
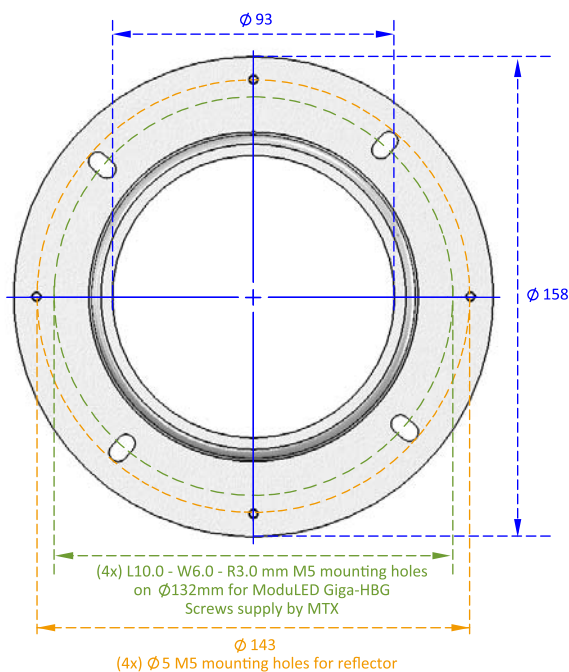

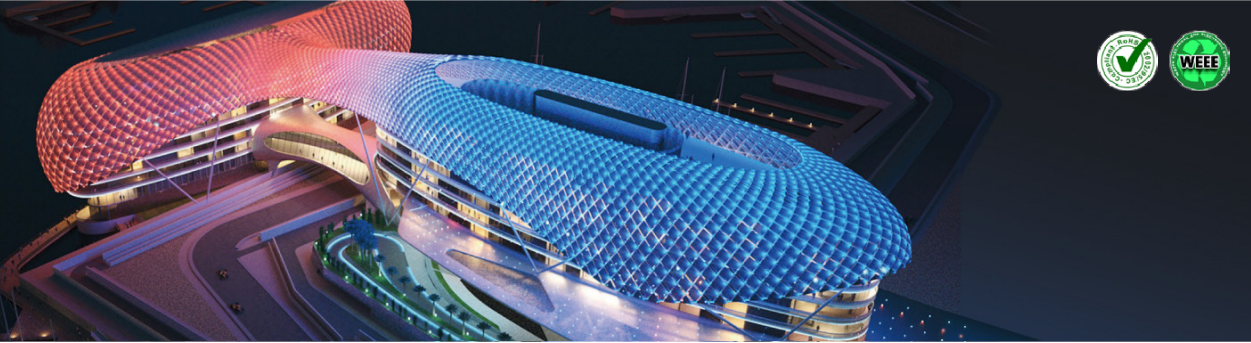

## ModuLED Optics Adaptor v2 for Reflector & Lens connection

### Mounting Instructions

Mounting indicator marks overview on ModuLED HBG series LED Coolers:

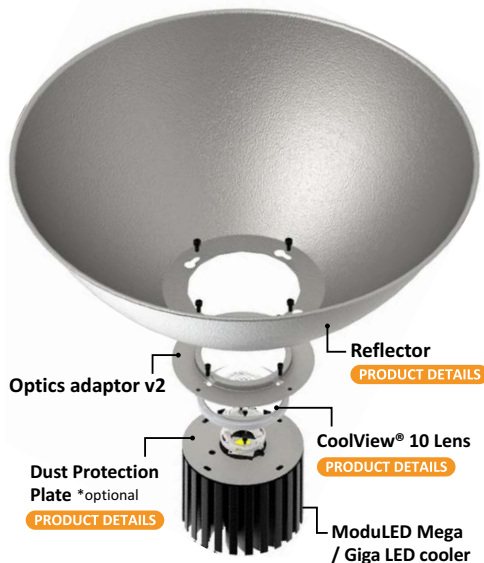
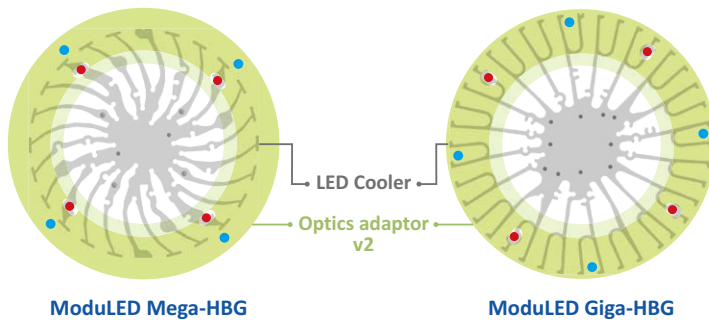

### Adaptor plate for connection of reflector & lens on ModuLED HBG series

With the ModuLED Mega / Giga optics adaptor v2 you get an unprecedented flexibility in choices of optics. Equipping your high bays with a wide variety of reflectors in metal or plastic, adding CoolView® 10 series anti-glare lenses for a controlled light image,... it all becomes plug-and-play.

#### Model Names

- ModuLED Mega optics adaptor v2
- ModuLED Giga optics adaptor v2

#### CoolView® 10 Lens & Dust Protection Plate Mounting

- Direct mounting on the LED cooler with 4 MTX screws M5 x 10mm  
Red indicator marks

#### CoolBay® Reflector Mounting

- Direct mounting on optics adaptor with 4 screws M5 x 6mm  
Blue indicator marks

\* Dust Protection Plate is an optional accessory go along with lens or any reflector with cover to avoid dust accumulation - no needed when you equip your high bay with a non-cover reflector only.

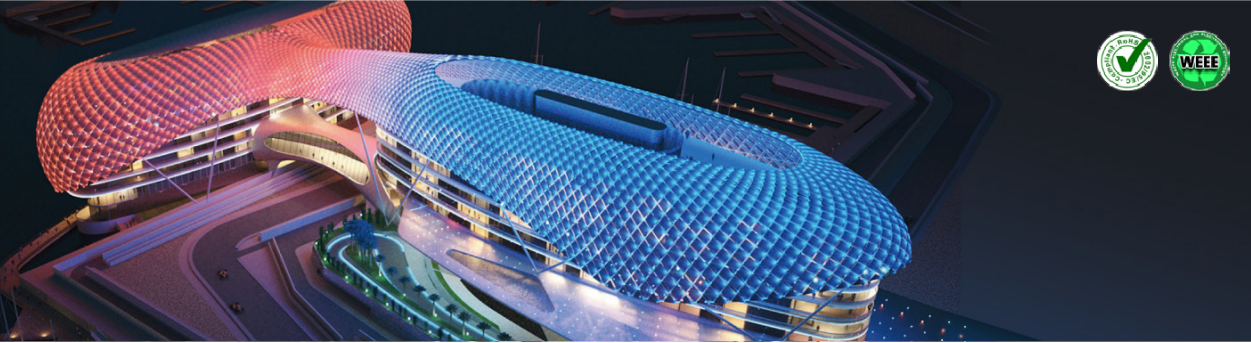

## ModuLED Optics Adaptor v2 for Reflector & Lens connection

### Product Details

Model n°	ModuLED Mega optics adaptor v2	ModuLED Giga optics adaptor v2
Dimension (mm)	ø158 - H16.9	ø158 x H16.9
Weight (gr)	60	61.5
Material	AL-1050	AL-1050

#### Notes:

- MechaTronix reserves the right to change products or specifications without prior notice.
- Mentioned models are an extraction of full product range.
- For specific mechanical adaptations please contact MechaTronix.





## ModuLED Optics Adaptor v2 for Reflector & Lens connection

### Features & Benefits

- Specific designed adaptor plate for assembly of CoolView® 10 series lenses and CoolBay® Reflectors on ModuLED Mega / Giga series high bay LED Coolers.
- With the ModuLED optics adaptor you get an unprecedented flexibility in choices of optics. Equipping your high bays with a wide variety of reflectors in metal or plastic, adding CoolView® 10 series anti-glare lenses for a controlled light image,... it all becomes plug-and-play.
- With the Dust Protection Plate you can prevent dust accumulation in the lens or reflector cover through open structure of the ModuLED cooling fins.



### Order Information

Example : ModuLED Mega optics adaptor v2

ModuLED **1** optics adaptor v2

- 1** LED cooler compatibility  
Mega - for ModuLED Mega-HBG  
Giga - for ModuLED Giga-HBG

Optics total assembly example:

