

Wakeable high-speed CAN isolated transceiver module

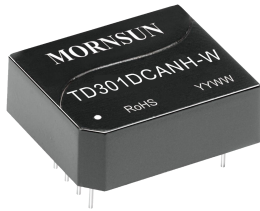

FEATURES

- Comply with ISO11898-2, ISO11898-5 standards
- With standby control pin
- Ultra-low standby current
- With bus dominant timeout protection
- With remote wake-up function
- Two-port isolation (3.0kVDC)
- Operating ambient temperature range: -40°C to +105°C
- Set isolation and ESD bus protection in one
- EN62368 approval

The TD301DCANH-W/ TD501DCANH-W series' main function is to convert TTL / CMOS level into isolated CAN bus differential level signals. The use of IC integrated technology allows for power isolation, signal isolation, CAN transceiver and bus protection all in one single CAN bus transceiver module, which withstands an isolation test voltage of 3000VDC. Also, they can easily be embedded in the user's end equipment, to achieve fully functional CAN bus network connectivity. The internal intermittent working design makes the product series have extremely low power consumption in standby mode, which is suitable for occasions with special requirements for low power consumption.

Selection Guide

Certification	Part No.	Power input (VDC)	Stand-by current (mA) (Typ.)	Baud rate (bps)	Static Current (mA) (Typ.)	Maximum Operating Current (mA)	Bus Maximum Voltage (VDC)	Number of Nodes
CE	TD301DCANH-W	3.3	1.5	40K-1M	18	90	±40	110
	TD501DCANH-W	5	1.5	40K-1M	20	100	±40	110

Absolute Limits

Item	Operating Conditions	Min.	Typ.	Max.	Unit
Input Surge Voltage (1sec.max.)	3.3V series	-0.7	--	5	VDC
	5.0V series	-0.7	--	7	
Pin Soldering Temperature	Soldering spot 1.5mm away from case, 10s max.	--	--	300	°C

3.3V Input Specifications

Item	Symbol	Min.	Typ.	Max.	Unit
Power Supply Input Voltage	VCC	3.15	3.3	3.45	VDC
TXD Logic Level	High-level	V _{IH}	--	V _{CC} +0.5	
	Low-level	V _{IL}	--	0.3V _{CC}	
RXD Logic Level	High-level	V _{OH}	V _{CC} -0.2	--	
	Low-level	V _{OL}	0	0.4	
TXD Drive Current	I _T	2	--	--	mA
RXD Output Current	I _R	--	--	2	
Serial Interface	Standard CAN controller interface for +3.3V				

5.0V Input Specifications

Item	Symbol	Min.	Typ.	Max.	Unit
Power Supply Input Voltage	VCC	4.75	5	5.25	VDC
TXD Logic Level	High-level	V _{IH}	--	V _{CC} +0.5	
	Low-level	V _{IL}	--	0.3V _{CC}	
RXD Logic Level	High-level	V _{OH}	V _{CC} -0.2	--	
	Low-level	V _{OL}	0	0.4	
TXD Drive Current	I _T	2	--	--	mA

RXD Output Current	I_R	--	--	2	
Serial Interface	Standard CAN controller interface for +5.0V				

STB Pin Input Specifications

Item		Symbol	Min.	Typ.	Max.	Unit
STB Control Level	High-level (Normal Mode)	V_{STB_IH}	2	--	5	V
	Low-level or Floating (Standby Mode)	V_{STB_IL}	0	--	0.5	
STB Pull-down Resistor		R_{STB_RD}	--	10k	--	Ω

Transmission Specifications

Item		Symbol	Min.	Typ.	Max.	Unit
Data Delay	TXD Transmitter Delay	t_T	--	140	190	ns
	RXD Receiver Delay	t_R	--	160	210	
	Cycle Delay	$t_{PRO(TXD-RXD)}$	--	300	400	
Dominant Timeout		$t_{to(dom)TXD}$	0.3	0.45	0.7	mS
Mode Switching Stabilization Time	STB:Low-High	$t_{STB_DELAY_UP}$	--	--	70	μs
	STB:High-Low	$t_{STB_DELAY_DOWN}$	--	--	350	
Standby Wake-up Filtering Time		t_{WK_FT}	0.7	1.8	5	

Output Specifications

Item		Symbol	Min.	Typ.	Max.	Unit
Dominant Level (Logic 0)	CANH	$V_{(OD)CANH}$	2.75	3.5	4.5	VDC
	CANL	$V_{(OD)CANL}$	0.5	1.5	2.0	
Recessive Level (Logic 1)	CANH	$V_{(OR)CANH}$	2	2.5	3	
	CANL	$V_{(OR)CANL}$	2	2.5	3	
Differential Level	Dominant Level (Logic 0)	$V_{diff(d)}$	1.5	2	3	
	Recessive Level (Logic 1)	$V_{diff(r)}$	-0.05	0	0.05	
Bus Pin Maximum Withstand Voltage		V_x	-40	--	+40	
Bus Transient Toltage		V_{TT} , Meet ISO7637-3 standard	-200	--	+200	
Bus Pin Leakage Current		($V_{CC}=0V, V_{CANH/L}=5V$)	-5	--	5	μA
Load Resistance Differential		R_L	45	60	65	Ω
Input Impedance Differential		R_{diff}	30	--	80	$k\Omega$
CAN Bus Interface	Meets ISO/DIS 11898-2 standard Twisted-pair output					

General Specifications

Item	Operating Conditions	Value
Isolation Test	Electric strength test for 1 min., leakage current <1mA	3.0 kVDC
Insulation Resistance	At 500VDC	1000M Ω (input-output)
Operating Temperature		-40 $^{\circ}C$ to +105 $^{\circ}C$
Transportation and Storage Temperature		-55 $^{\circ}C$ to +125 $^{\circ}C$
Operating Humidity	Non-condensing	10% - 90%
Safety Standard		EN62368
Safety Certification		EN62368
Safety Class		CLASS III

Mechanical Specifications

Case Material	Blackflame-retardant heat-proof plastic (UL94 V-0)
Package	DIP10
Weight	4.2g (Typ.)
Cooling Method	Free air convection

Operating mode

Mode	VCC		STB	TXD	RXD	Bus characteristics	Wake-up function
Normal mode	TD301DCANH-W	3.15~3.45V	High level	Low, bus dominant High, bus recessive	Bus dominant, low Bus recessive, high	The driver is controlled by TXD, and the receiver returns the bus status to RXD	Disable
	TD501DCANH-W	4.75~5.25V					
Standby mode	TD301DCANH-W	3.15~3.45V	Low level / Floating	Does not affect the bus	Return wake signal	The bus is pulled down to the ground reference via an internal input resistor	Enable
	TD501DCANH-W	4.75~5.25V					
Not powered	TD5(3)01DCANH-W	0V	X	X	--	High impedance without affecting the bus	No

Electromagnetic Compatibility (EMC)

Emission	CE	CISPR32/EN55032	CLASS A (Fig.5)	
Immunity	ESD	IEC/EN 61000-4-2	Contact ± 4kV/Air ± 8kV (without external components, signal port)	Perf. Criteria B
	EFT	IEC/EN 61000-4-4	±2kV (without external components, signal port)	Perf. Criteria B
	Surge	IEC/EN 61000-4-5	±2kV (line to ground) (without external components, signal port)	Perf. Criteria B
		IEC/EN 61000-4-5	±2kV (line to ground), ±4kV (line to ground) (The recommended circuit is shown in Figure 6, signal port)	Perf. Criteria B
	CS	IEC/EN 61000-4-6	3Vr.m.s (without external components)	Perf. Criteria A

Note: (1) The input voltage cannot exceed the specified range, otherwise permanent damage may occur.

(2) The ESD, EFT, surge are limited to the CAN communication port, and the CAN bus port is left floating during the test.

Application Precautions

1. Carefully read and follow the instructions before use; contact our technical support if you have any question;
2. Do not use the product in hazardous areas;
3. Use only DC power supply source for this product. 220V AC power supply is prohibited;
4. It is strictly forbidden to disassemble the product privately in order to avoid product failure or malfunction.
5. Hot-swap is not supported.
6. If the external input of TXD is insufficient, the pull-up resistor should be added according to the situation.

After-sales service

1. Factory inspection and quality control are strictly enforced before shipping any product; please contact your local representative or our technical support if you experience any abnormal operation or possible failure of the module;
2. The products have a 3-year warranty period, from the date of shipment. The product will be repaired or exchanged free of charge within the warranty period for any quality problem that occurs under normal use.

Applied circuit

Refer to the CAN Industrial Bus Interface Isolating Module Application Manual.

Design Reference

1. Typical application circuit

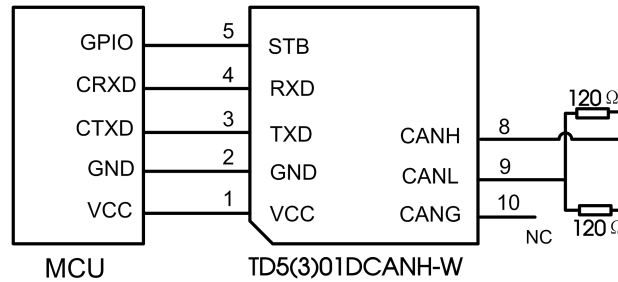

Fig.1

Figure 1 shows a typical application circuit for connecting a module. The module with its integrated power supply, CAN controller and CAN bus network interface can generally be used by customers as is, without the need of adding peripheral circuits. Note: The logic level of the CAN controller should be compatible with the TD5(3)01DCANH-W.

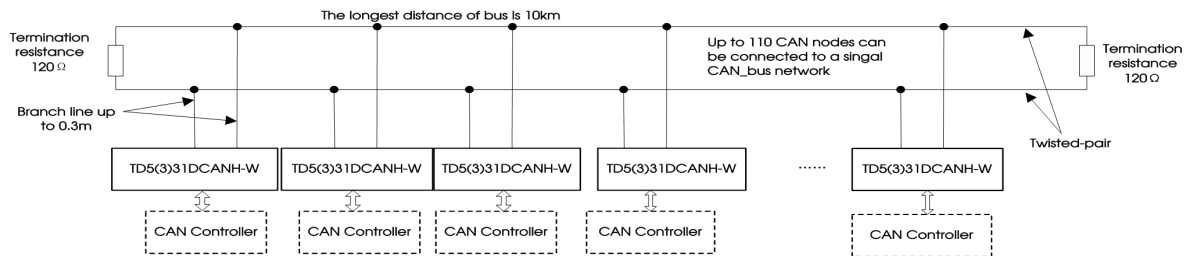

Fig.2

As shown in Fig 2, a single CAN-bus network allows connecting as many as 110 isolated single-channel TD_CAN transceiver modules. This universal type module supports a maximum communication distance of 10km while the high-speed type module can support a maximum communication distance of 1km with a baud rate beyond 40kbps. For accessing more nodes or achieving longer communication distances, CAN repeaters or other expansion equipment can easily be used.

Note: The communication distance of the bus is related to the communication speed and its field application. It can be designed according to the actual application and reference standard. We recommended the use of a twisted pair or shielded twisted pair as the communication cable and it should be kept away from any sources of interference. For long-distance communication, the terminal resistance value needs to be selected in accordance with the communication distance, the cable impedance and the number of nodes.

In order to ensure the normal working voltage can be established after the module is powered on, the module must be in a normal working state when the module is powered on, that is, the STB pin is high. The wake-up CAN series is affected by the STB pin control and dominant timeout protection. There are four working modes, as described below.

1.1 Normal mode

When the STB pin is high, the module enters the normal communication working mode. The normal communication working mode is the same as the normal CAN communication module. The module driver can convert the TXD digital signals into CAN signals. The module receiver can convert the CAN signals into RXD Digital signal.

1.2 Standby mode

When the STB pin level is low or left floating, the module enters the low-power standby mode. In the low-power standby mode, the transmitter and receiver are turned off. The module cannot send data to the CAN bus through the TXD pin, and I send Receive the CAN bus data information correctly. At this time, the module's RXD pin remains high until the module detects a valid bus wake-up signal. After the module detects a valid bus wake-up signal, the RXD pin returns to a dominant level on the bus that lasts longer than t_{WK_FT} , until it resumes normal mode from standby mode. After the user control system detects the RXD wake-up signal, the module can enter the normal working mode by pulling up the STB pin level.

In standby mode, the CANH and CANL pins of the module are pulled down to the reference CANG through the internal input resistor.

1.3 Remote wake-up mode

The module's internal filtering function can filter short-term bus interference signals to prevent the module from awakening by mistake. After the module detects a valid bus wake-up signal, the module will return a bus signal at RXD. When the duration of the bus wake-up signal is greater than t_{WK_FT} , the signal can be accurately identified. When t_{WK_FT} is in different ranges, the following three situations will occur:

The wake-up signal duration is less than $t_{WK_FT(MIN)}$, the wake-up signal is filtered, and the RXD will not output a wake-up signal.

The wake-up signal duration is between $t_{WK_FT(MIN)}$ and $t_{WK_FT(MAX)}$. The wake-up signal may be filtered out and RXD may output the wake-up signal.

The wake-up signal duration is greater than $t_{WK_FT(MAX)}$, RXD will definitely output the wake-up signal.

The wake-up signal is held in order to ensure that the wake-up function is effective. The complete wake-up signal dominant duration must be greater than $t_{WK_FT (MAX)}$. During the wake-up period, signals that do not meet the requirements will be filtered out. The complete wake-up signal will set the RXD pin low. To receive a dominant level on the bus that lasts longer than t_{WK_FT} . After the user controller detects the wake-up signal output from the RXD pin, the product can enter the normal communication mode by pulling up the STB pin level. The schematic diagram of standby wake-up is shown in Figure 3.

1.4 Dominant time out

When TXD is continuously low, the module's internal overtime protection function will be activated. If the TXD pin stays low for longer than $t_{to (dom) TXD}$, the internal transmitter will be disabled and the bus will be released to a stealth level. The explicit timeout function can prevent the system from causing the bus to maintain the dominant level continuously, and prevent the system from paralyzing the bus due to a node problem. When the TXD pin is set high, the dominant timeout timer is reset. Figure 4 shows the timing diagram of the dominant timeout function.

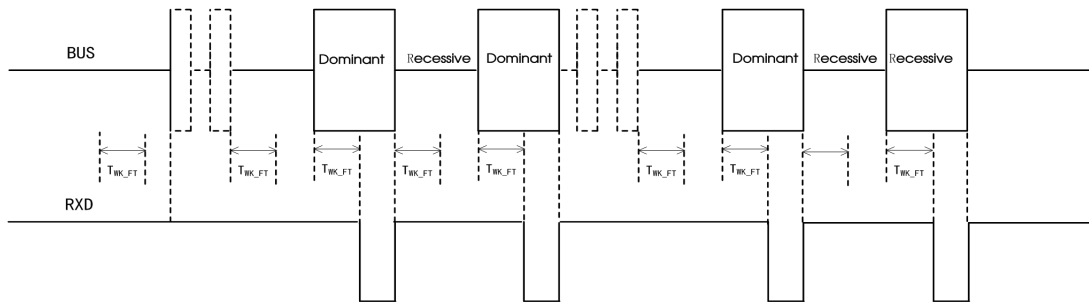

Fig 3 Wake-up timing diagram in standby mode

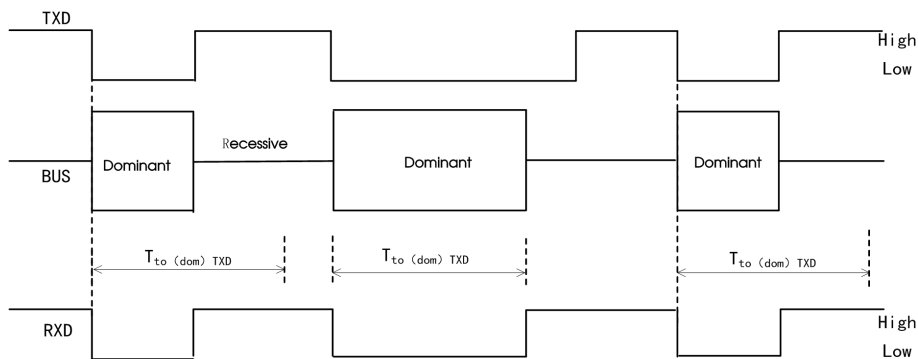
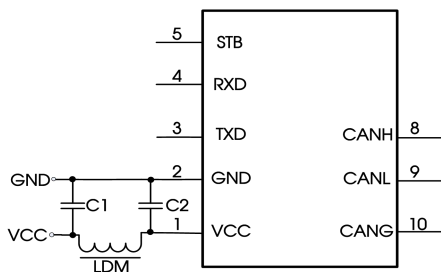

Fig 4 Explicit timeout function timing diagram



Component	Recommended part, value
C1, C2	1uF/16V
LDM	CD43-12uH

Fig.5

2. Recommended port protection circuit

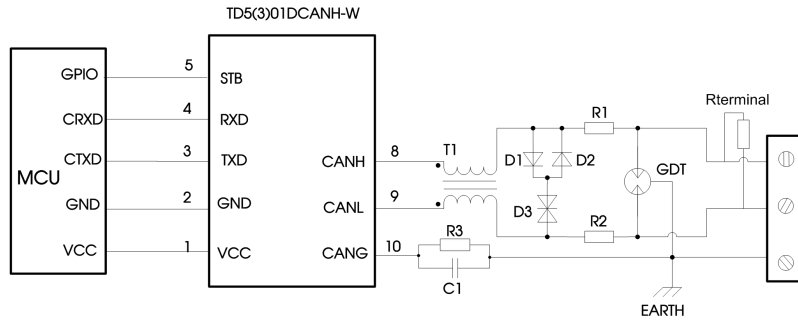

Fig.6

Note: Ground shield of twisted wire pair reliably.

Recommended components and values:

Component	Recommended part, value	Component	Recommended part, value
R3	1MΩ	R1, R2	2.7Ω /2W
C1	1nF, 2kV	D1, D2	1N4007
T1	ACM2520-301-2P	D3	SMBJ30CA
GDT	B3D090L	Rterminal	120Ω

When the module is used in applications with harsh environment, it can be susceptible to large energy like lightning strike, etc. in which case, it is essential to add an adequate protection circuit to the CAN signal ports to protect the system from failure and maintain a reliable bus communication. Figure 5 provides a recommended protection circuit design for high-energy lightning surges, with a degree of protection related to the selected protection device. Parameter description lists a set of recommended circuit parameters, which can be adjusted according to the actual application situation. Also, when using the shielded cable, the reliable single-point grounding of the shield must be achieved.

Note: The recommended components that will change the Specifications of Bus Pin Maximum Withstand Voltage by D3 and its values is a general guideline only. It must be verified for the actual user’s application. We recommended using PTC’s for R1 and R2 and to use fast recovery diodes for D1 and D2.

3. For additional information, please refer to our application note on www.mornsun-power.com

Dimensions and Recommended Layout

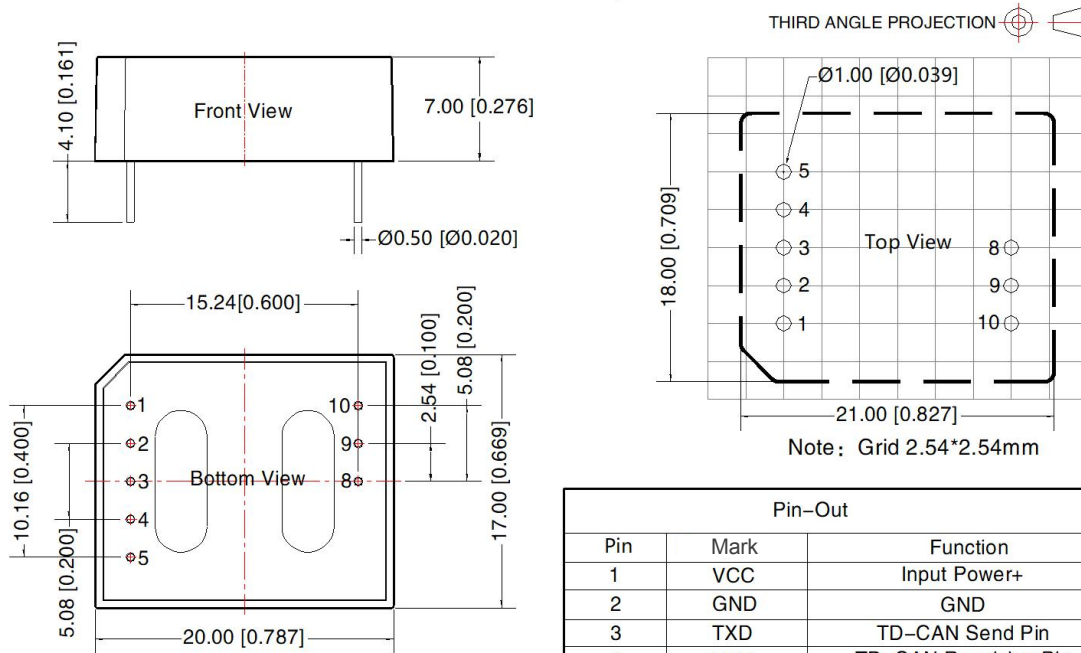

Note:
 Unit: mm[inch]
 Pin diameter tolerances: $\pm 0.10[\pm 0.004]$
 General tolerances: $\pm 0.50[\pm 0.020]$

Pin-Out		
Pin	Mark	Function
1	VCC	Input Power+
2	GND	GND
3	TXD	TD-CAN Send Pin
4	RXD	TD-CAN Receiving Pin
5	STB	Standby control Pin
8	CANH	TD-CAN H Pin
9	CANL	TD-CAN L Pin
10	CANG	Isolation Power Output CANG

Notes:

- For additional information on Product Packaging please refer to www.mornsun-power.com. The Tube Packing bag number: 58240012;
- Unless otherwise specified, parameters in this datasheet were measured under the conditions of $T_a=25^{\circ}\text{C}$, humidity<75%RH with nominal input voltage and rated output load;
- All index testing methods in this datasheet are based on company corporate standards;
- The above are the performance indicators of the product models listed in this datasheet. Some indicators of non-standard models will exceed the above requirements. For details, please contact our technical staff;
- We can provide product customization service, please contact our technicians directly for specific information;
- Products are related to laws and regulations: see "Features" and "EMC";
- Our products shall be classified according to ISO14001 and related environmental laws and regulations, and shall be handled by qualified units.

MORNSUN Guangzhou Science & Technology Co., Ltd.

Address: No. 5, Kehui St. 1, Kehui Development Center, Science Ave., Guangzhou Science City, Huangpu District, Guangzhou, P.R. China
 Tel: 86-20-38601850 Fax: 86-20-38601272 E-mail: info@mornsun.cn www.mornsun-power.com