

1300W, isolated DC-DC converter
Wide input and regulated single output



Patent Protection

RoHS



FEATURES

- Wide input voltage range: 45-60VDC
- High efficiency up to 97.3% (Half load)
- I/O isolation test voltage 1500VDC
- Operating ambient temperature range: -40°C to +85°C
- Input under-voltage protection, over-voltage, over-current protection, output short-circuit, over-temperature protection
- Droop current sharing, bus current sharing
- Built-in PMBus communication function
- Industry standard package: 1/4 brick
- Meets EN62368 standards

VCB48_QBO-1300WR3A-N series is a high-performance product designed for the field of communication power supply. It features with output power up to 1300W, no minimum load requirement, 45-60VDC wide voltage input, allowable operating temperature up to 85°C, with input under-voltage protection, output over-voltage protection, output over-current protection, output short-circuit protection, over-temperature protection, remote control, output voltage regulation, current sharing, PMBus communication and other functions. It meets CISPR32/EN55032 CLASS B via additional circuit and they are widely used in communications, battery-powered equipment, industrial control, electric power, instrumentation, intelligent robots and other fields.

Selection Guide

Certification	Part No. ^①	Ctrl ^⑦	Current sharing type ^②	Input Voltage (VDC)		Output		Nominal Efficiency(%) 50%Io/100%Io	Capacitance Load(μF) ^⑥	
				Nominal (Range)	Max. ^③	Voltage (VDC) ^④	Current (mA) 50%Io/100%Io.		Typ. ^⑤	Max.
--	VCB4810QBO-1300WR3A-N	N	ACS	53 (45-60)	65	10.8	54100/108300	97.0/96.2	3500	15000
	12					97.3/96.5				

Notes:
 ① Use suffix "A" for product with ACS bus current sharing function, suffix "D" for DLS droop current sharing function;
 ② ACS means bus current sharing, DCS means droop current sharing, each product only with one current sharing type;
 ③ The input voltage cannot exceed this value, otherwise it may cause permanent irreversible damage, in order to improve product reliability. By default, if Vin exceeds 75VDC (Typ.) product will shut down the power output;
 ④ The output voltage is tested under the conditions of nominal input and no-load output;
 ⑤ In order to ensure the stability of the output voltage, at least one minimum capacitive load must be externally connected to the output side of the product, details please refer to Fig.2 in Design Reference;
 ⑥ Capacitive load test conditions: room temperature, Vin = 45-60V, 100%Io;
 ⑦ "P" indicates positive logic, "N" indicates negative logic. The corresponding positive logic model is VCB48_QBO-1300WR3A, and the corresponding negative logic model is VCB48_QBO-1300WR3A-N.

Input Specifications

Item	Operating Conditions	Min.	Typ.	Max.	Unit
Input Current (full load)	Room temperature, Vin = 53 V	--	--	28	A
No Load Input Loss	Room temperature, Vin = 53 V	--	6.6	--	W
Input Capacitance Value	Room temperature, Vin = 53 V	5			μF
Surge Voltage(100msec. max.)	Room temperature	-0.5	--	80	VDC
Max Input Voltage	Room temperature	--	--	65	
Input Start-up Voltage ^④	Output voltage enabled level, PMBus configurable	41	42	43	
Input Under-voltage Protection	Output voltage disable level, PMBus configurable	39	40	41	
Input Filter		Pi filter			
Hot Plug		Unavailable, it is necessary to ensure that the input and output capacitors without voltage before loading and unloading the product			
Ctrl ^⑦	Module turn-on	Room temperature	0	--	1.2

	Module turn-off	Room temperature	2.5	--	5.5	VDC
	CTRL flip typical value voltage (CTRL pin floating voltage)	Room temperature	--	1.7	--	
	Input current ^②	Room temperature, Vin = 53 V	--	0.3	--	mA
	Input loss during shutdown		--	1	--	W
	Functional delay time ΔT_1 ^③		--	1	--	
Start-up Delay Time ΔT_2 ^③	Room temperature, Vin = 53 V	VCB48_QBO-1300WR3A-N [®]	--	11	20	ms

Notes:

- ① CTRL control pin voltage is relative to input pin GND; The input voltage cannot exceed 5VDC, otherwise it may cause permanent damage;
- ② External circuit current capability required for CTRL enable;
- ③ ΔT_1 and ΔT_2 see the picture below;

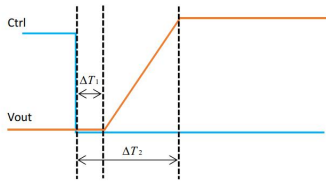

- ④ Under different Vin, the Vo needs to be lower than the voltage corresponding to the controllable output voltage curve of the Design Reference Fig. 6, so as to ensure the closed-loop controllability of the output voltage; The load condition test needs to ensure that the input voltage is stable;
- ⑤ When VCB48_QBO-1300WR3A-N uses PMBus to enable the ACS (bus current sharing) function, the specifications are 201ms(Typ.) or 210ms(Max.);
- ⑥ The input voltage is 45-51V, and the output power is linearly derated to 1160-1300W. The input voltage is 51-60V, and the output power is 1300W.

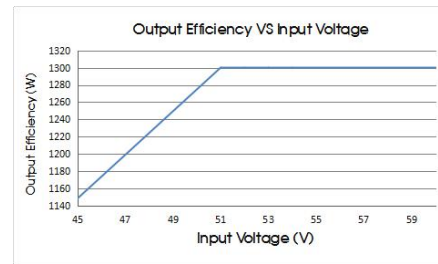
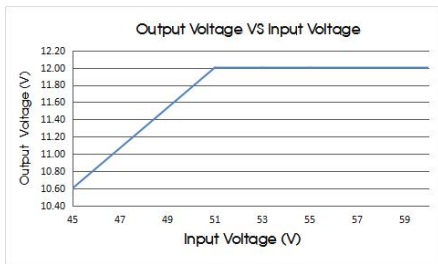

Output Specifications

Item	Operating Conditions ^①	Min.	Typ.	Max.	Unit
Output Current Range		0	--	100	%Io
Voltage Accuracy	Room temperature, Vin = 51-60 V, 0%-100%Io	--	--	±2	%
Linear Regulation	Vin = 51-60 V, 100%Io	--	±0.2	±0.5	
Load Regulation	Room temperature, Vin = 53 V, 0%-100%Io	--	±0.5	±0.75	
Transient Recovery Time	Vin = 53 V, 25-75-25% Io, di/dt = 2.5 A/ μ s	--	250	450	μs
Transient Response Deviation	Vin = 53 V, 25-75-25% Io, di/dt = 2.5 A/ μ s	--	±3	±5	%
	Vin = 53 V, 10-100-10% Io, di/dt = 2.5 A/ μ s	--	--	±15	
Temperature Coefficient	100%Io	--	--	±0.03	%/°C
Ripple & Noise ^②	Room temperature, Vin = 45-60 V, 0%-100%Io	--	--	100	mVp-p
Output voltage regulation range ^③	Room temperature, Vin = 45-60 V, 0%-100%Io	8	--	12	VDC
Over-temperature Protection	Product surface max. temperature	--	110	120	°C
Over-voltage Protection	Vin = 53 V, 10%Io	--	14.4	--	%Vo
	Response type	Output off, re-power on for recover			
Over-current Protection	Vin = 45-60 V, Room temperature(product temperature)	--	135	140	A
	Response type	VCB48_QBO-1300WR3A-N	①Hiccup, continuous, self-recovery ②When ACS (bus current sharing) is enabled, the system shuts down immediately when over-current protection is triggered, re-power		

			on for recover ③The minimum current limit for a group of N devices in parallel is 140A*N			
Short-circuit Protection	Vin = 45-60 V	VCB48_QBO-1300WR3A-N	①Hiccup, continuous, self-recovery ②When ACS (bus current sharing) is enabled, the system shuts down immediately when Short-circuit Protection is triggered, re-power on for recover			
Start-up Time ΔT_3 ④	Vin = 53 V, Constant resistance load	VCB48_QBO-1300WR3A-N	--	50	70	ms
Initialization time	From Vin $\geq 27V$ to ready enable		--	18	--	
Output voltage total start up delay time	The input voltage is enabled		40	--	--	
	Enable by CTRL or PMBus CTRL pin		--	1	--	
Output voltage on delay time⑤	Default startup delay of PMBus		--	1	--	
	TON_DELAY range		0	--	655	
	Accuracy (actual delay and set value)		--	1	--	
Output voltage off delay time⑥	Default off delay of PMBus		--	1	--	
	TOFF_DELAY range		0	--	655	
	Accuracy (actual delay and set value)		--	1	--	
Output voltage rise time ΔT_4 ④	Room temperature, 0%-100%Io	VCB48_QBO-1300WR3A-N⑦	--	10	15	
Output Voltage Start-up Delay Abnormal Fault Time⑧	Room temperature, 0%-100%Io	VCB48_QBO-1300WR3A-N	15	--	--	
Output voltage drop time	Room temperature, 0%-100%Io		--	--	--	
The output voltage rises/falls	TON_RISE/TOFF_FALL range		10	--	655	
	Accuracy of rise/fall time (actual rise/fall time and set value)		--	1	--	
Output voltage adjustment rate⑩	Default output voltage adjustment rate of PMBus		--	0.1	--	
	VOUT_TRANSITION_RATE range Room temperature, 0%-100%Io, no current sharing, no parallel		0.001	--	1.2	V/ms

Notes:

- ① All output characteristics are tested in accordance with Design Reference Fig. 2;
- ② The ripple & noise is tested in accordance with Design Reference Fig. 3;
- ③ For details, please refer to Power Supply Management Fig. 11;
- ④ The VCB48_QBO-1300WR3A-N marked here indicates that ACS is disabled by default; ΔT_3 and ΔT_4 see the picture below;

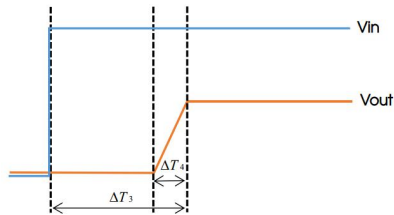

- ⑤ By default, the minimum output voltage start-up delay time is 1ms, which is equivalent to the "Enable by CTRL or PMBus CTRL Pin" time. The "TON delay-1" delay time is directly superimposed to the input voltage start-up delay time;
- ⑥ The output voltage off delay takes effect only when the output is turned off by CTRL and PMBus CTRL control. Under normal conditions, the power off does not delay;
- ⑦ VCB48_QBO-1300WR3A-N When PMBus is used to enable ACS (bus current sharing) function, the output voltage rise time, start time, output voltage start delay abnormal fault time specification is 210ms(Min.);
- ⑧ Output voltage start-up delay abnormal fault time refers to the time for attempting to restart when the output voltage does not exceed the set value of output under-voltage fault (0x44). If exceeds the time, it is regarded as a fault, the output will be off and need to restart;
- ⑨ Output voltage drop time refers to the time when the output voltage drops from the set voltage to 1V. When the output voltage is turned off by pressing CTRL, PMBus CTRL, or OPERATION (0x01), the output voltage can be turned off at this time;
- ⑩ The output voltage adjustment rate refers to the change speed of the output voltage when the output voltage is adjusted online by the VOUT COMMAND (0x21) in steady state operation. It is not allowed to adjust the output voltage online when the current is shared simultaneously;
- ⑪ The load adjustment rate specification applies only to the case of bus equalization;
- ⑫ After the ACS function is enabled, only the output voltage accuracy of the product is controlled, and the load adjustment rate of the product is not controlled.

General Specifications

Item	Operating Conditions		Min.	Typ.	Max.	Unit
Isolation	Electric Strength Test for 1 minute with a leakage current of 5mA max	Input-output	--	--	1500	VDC
		Output-case	--	--	500	
Insulation Resistance	Input-output, resistance at 500VDC		100	--	--	MΩ
Isolation Capacitance	Input-output, 100KHz/0.1V		--	8200	--	pF
Operating Temperature			-40	--	+85	°C
Storage Temperature			-55	--	+125	
Storage Humidity	Non-condensing		5	--	95	%RH
Pin Soldering Resistance Temperature	Wave soldering welding, 10 seconds		--	--	260	°C
	Soldering spot is 1.5mm away from case for 10 seconds		--	--	300	
Shock And Vibration			10-500Hz, 0.07g2/HZ, 10min. along X, Y and Z			
Switching Frequency	Switching frequency setting value	PWM mode, room temperature, Vin = 45-60 V, 0%-100%Io	--	180	--	KHz %
	Switching frequency adjustment range	Room temperature	180	180	250	
	Switching frequency adjustment step ^①	Room temperature	--	1	--	
	Switching frequency accuracy	Room temperature	-10	--	10	
External Synchronization Pulse Width			256	--	--	ns
Synchronization Switch Frequency Accuracy	External SYNC signal input		-8		8	%
MTBF	MIL-HDBK-217F @25°C		6000	--	--	K hours
Notes:						
① Switching frequency Settings should be configured in integer multiples of 1kHz.						

PMBus Electrical specification

Item	Operating Conditions	Min.	Typ.	Max.	Unit	
Logic Output Low Signal Level (V _{OL})	SCL, SDA, SYNC, SALERT, PG IOH= 4 mA	--	--	DGND +0.25	VDC	
Logic Output High Signal level (V _{OH})		VDD-0.6	--	--		
Logic Output High Source current (I _{OH})		--	--	4	mA	
Logic Output Low Sink Current (I _{OL})		-4	--	--		
Logic Input High Threshold (V _{IH})	VDD=3V	2.1	--	--	VDC	
Logic Input Low Threshold (V _{IL})		--	--	1.1		
Parasitic Capacitance		--	--	400	pF	
SYNC Pin Capacitance	Parallel interleaving	--	100	--		
Internal Pull-up Resistance	PMBus CTRL	--	47	--	KΩ	
PMBus Operating Frequency	Slave mode: PMBUS 50% duty cycle	100	400	1000	KHz	
		--	400	--		
STOP TO START Min Time t _(BUFP)	See System Management Bus Specification Version 3.0	--	1.3	--	μs	
START Continue Time t _(HD:STA)		--	0.6	--		
Repeat START Time t _(SU:STA)		--	0.6	--		
STOP Continue Time t _(SU:STO)		--	0.6	--		
Data Continue Time t _(HD:DAT)		--	0	--		
Data Set Time t _(SU:DAT)		--	100	--		
Error Signal Time t _(TIMEOUT)		--	--	35		ms
Clock Low Level Time t _(LOW)		--	1.3	--		μs
Clock High Level Time t _(HIGH)		--	0.6	--		
Clock Low Level Accumulated Time t _(LOW:SEXT)		--	--	25		ms

Note:
This data is obtained at 25°C, VCC=3.3V, 400kHz; The test data is applicable to all functional pins of PMBus, and the sequence diagram is as follows:

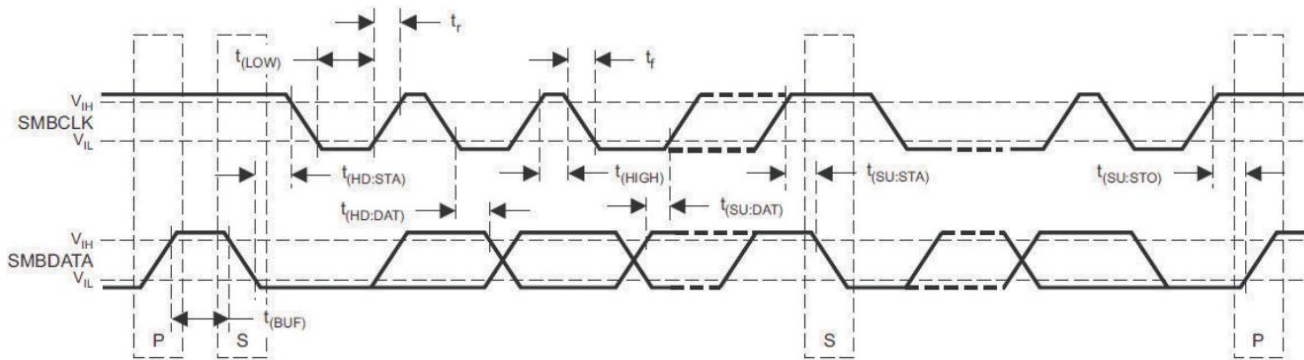

PMBus Design Specification

Item	Operating Conditions	Min.	Typ.	Max.	Unit	
Power Good, PG	PG Threshold	PMBus configurable Rising	--	8	--	VDC
		PMBus configurable Falling	--	5	--	
	PG Threshold Range	POWER_GOOD_ON VOUT_UV_FAULT_LIMIT	0	--	100	%Vout
	PG Delay	VO to POWER_GOOD_ON to PG set	--	139	--	µs
Input Under Voltage Protection, IUVP	IUVP Threshold	PMBus configurable	--	0	--	VDC
	IUVP Threshold Range	VIN_UV_FAULT_LIMIT	30	--	60	VDC
	IUVP Backlash voltage	PMBus cannot be configurable	--	2	--	VDC
	Set Point Accuracy		--	1	--	%
	IUVP Response Delay		--	500	--	µs
	Fault Response	PMBus configurable VIN_UV_FAULT_RESPONSE	Output off, self-recover when input voltage normal			
Input Over-voltage Protection, IOVP	IOVP Threshold	PMBus default over-voltage protection value is entered	--	--	75	VDC
	IOVP Threshold Range	VIN_OV_FAULT_LIMIT	0	--	100	%Vin
	IOVP Backlash voltage	PMBus cannot be configurable	--	5	--	VDC
	Set Point Accuracy		--	1	--	%
	IOVP Response Delay		--	500	--	µs
		Fault Response	PMBus configurable VIN_OV_FAULT_RESPONSE	Output off, self-recover when input voltage normal		
Output Voltage Over/under-voltage Protection, OVP / UVP	UVP Threshold	PMBus configurable	--	0	--	VDC
	UVP Threshold Range	VOUT_UV_FAULT_LIMIT	0	--	100	%Vout
	OVP Threshold	PMBus configurable	--	14.4	--	VDC
	OVP Threshold Range	VOUT_OV_FAULT_LIMIT	0	--	14.4	
	OVP/UVP response time		--	1 & 139	--	µs
		Fault Response	PMBus configurable VOUT_UV_FAULT_RESPONSE PMBus configurable VOUT_OV_FAULT_RESPONSE	Default off type, can be configured to hiccup, self-recovery		
Over Current Protection	OCP Threshold ^①	PMBus configurable	--	135	--	A
	OCP Threshold Range	IOUT_OC_FAULT_LIMIT	0	--	160	
	Over current & short circuit protection delay		--	139 & 1	--	ms
Over-temper	OTP Threshold	PMBus configurable	--	120	--	°C

Temperature Protection	OTP temperature return difference	PMBus cannot be configurable	--	5 ^③	--	
	OTP Threshold Range	OT_FAULT_LIMIT	-40	--	125	
	Fault Response	PMBus configurable OT_FAULT_RESPONSE	3s after the system shuts down, the OTP sampling point temperature returns to the "Threshold - Temp. Return Difference" , and the system automatically restarts if no fault occurs			
Monitoring Accuracy	Input voltage READ_VIN	Room temperature	--	±900	--	mV
	Output voltage READ_VOUT	Room temperature	--	±20	--	
	Output current READ_IOUT		--	3	--	A
	Duty cycle READ_DUTY_CYCLE		No tolerance, Read value is the actual value applied by PWM controller			
	Temperature READ_TEMPERATURE_1	Temperature sensor, -30~125°C	--	±10	--	°C
The number of products supported in the current sharing sample unit (including ACS)			--	3	--	
<p>Note:</p> <p>① When the product is working at current sharing mode, over-current will cause the product to be directly turned off, and the PMBus cannot be configured;</p> <p>② The product over-temperature protection point is set at the MCU temperature, which has a certain temperature difference with the maximum internal temperature of the product; If the maximum operating temperature is to be considered, the temperature rise assessment is required before specific debugging;</p> <p>③ Hysteretic parameters of some protection features are fixed and cannot be configured. Details are as follows: A. The hysteretic voltage of the input under-voltage protection is fixed to 2V, that is, the input voltage must be higher than the input under-voltage protection threshold of 2V before starting. The starting voltage is defined in accordance with instruction 0X35 VIN ON; B. The hysteretic voltage of the input over-voltage protection is fixed to 5V, that is, the input voltage must be lower than the input over-voltage protection threshold of 5V before starting; C. The hysteretic temperature of over-temperature protection is fixed to 5°C , that is, 3s after the system shuts down, the OTP sampling point temperature returns to the "Threshold - Temp. Return Difference" , and the system automatically restarts if no fault occurs;</p> <p>④ The PMBus setting limit has a specified maximum value. When the setting value is higher than the maximum value, the maximum value is set.</p>						

Mechanical Specifications

Case Material	Aluminum alloy case
Dimension	58.4*36.8*14.2 mm
Weight	85.8g (Typ.)
Cooling Method	Free air convection cooling or forced air cooling

Electromagnetic Compatibility (EMC)

EMI	CE	CISPR32/EN55032 CLASS A (see Fig. 4-1 for recommended circuit)/CLASS B (see Fig. 4-2 for recommended circuit)
	RE	CISPR32/EN55032 CLASS A (see Fig. 4-1 for recommended circuit)/CLASS B (see Fig. 4-2 for recommended circuit)

Typical Characteristic Curve

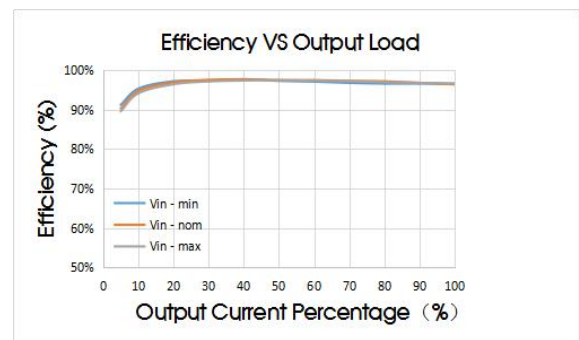
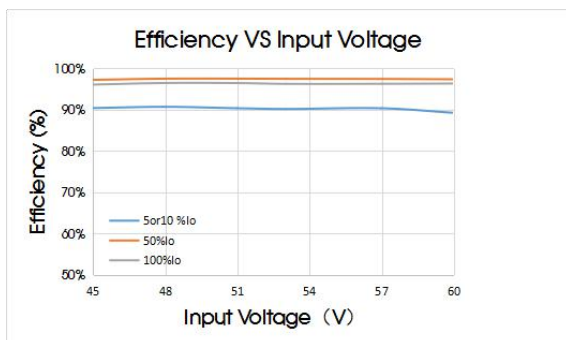

Fig. 1

Design Reference

1. Typical application circuit

The input voltage ranges from 45 to 60VDC. When the input voltage exceeds 60VDC, the power loss is higher than the normal input voltage. The maximum continuous input voltage is 65VDC.

If the customer does not use our EMC recommended circuits, the input must be connected with an electrolytic capacitor of at least 470µF to suppress the potential surge voltage at the input and ensure that the transient voltage does not exceed the value specified in the input surge voltage.

In addition, the impedance of both the input source and the load will interact with the impedance of the product, requiring the input source to have a low impedance characteristics. It is recommended that the minimum capacitance of the external input can be guaranteed to be 470 µF at low temperature. In some applications, performance can be enhanced by adding external capacitors. If the input voltage source contains significant inductance, add a low ESR ceramic capacitor of 22-100 µF to the input of the product to ensure stable operation. The minimum required capacitance depends on the output power and input voltage. The higher the output power, the larger the input capacitance.

The output end must be connected with an electrolytic capacitor larger than the minimum capacitance load capacity to stabilize the output state of the product.

If it is required to further reduce the input/output ripple, the external input/output capacitors Cin and Cout can be increased or a capacitor with small series equivalent impedance value can be selected, but the capacitance value should not be greater than the maximum capacitance load of the product.



Fig. 2

Output Voltage	Capacitors Value	Cout (typ.)	Cin
12V		3500µF ^①	470 µF

①: It is recommended to carry out peripheral design according to the typical value of capacitance load, and use aluminum electrolytic capacitors or solid electrolytic capacitors. The ratio of capacitance value can be referred to: 7x470µF + 270µF.

2. Ripple noise test circuit

In addition to the "1. Typical Application Circuit" capacitors, 10µF/35V tantalum capacitors and 0.1µF/25V ceramic capacitors should be added to the ripple noise test. It is recommended to use the following recommended peripheral circuit, and set the probe bandwidth to 20MHz during the test.

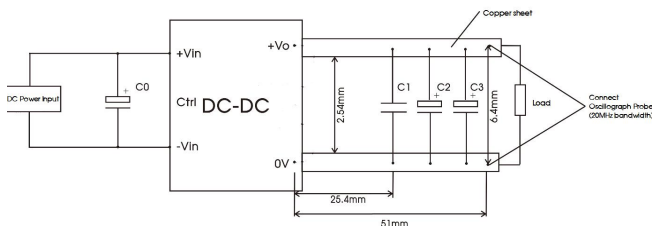
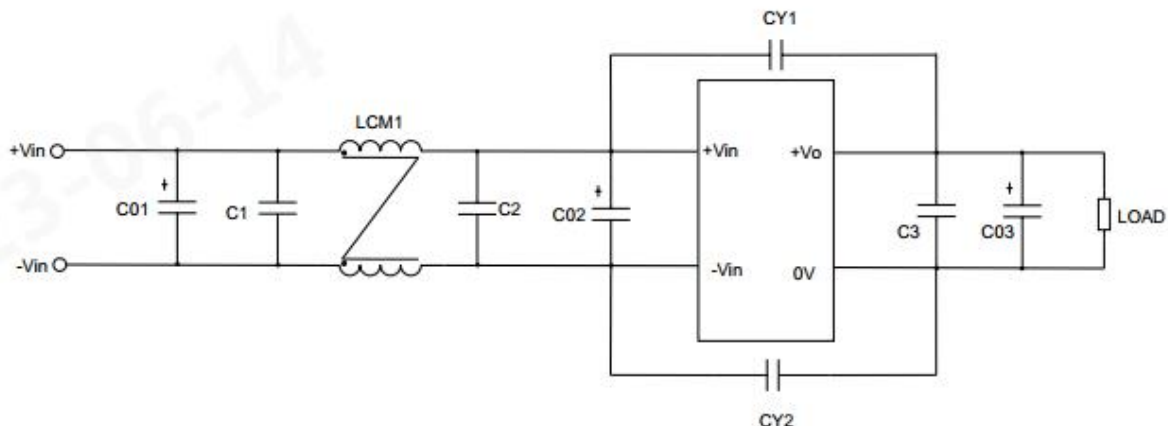

Fig. 3

Components	Recommended Component
C0	470µF/100V electrolytic capacitors
C1	0.1µF/25V ceramic capacitance
C2	10µF/25V Tantalum capacitor
C3	3500µF/25V aluminum electrolytic capacitor

3. EMC compliance circuit



Components	Recommended Component
C01	680μF/100V electrolytic capacitors
C02	470μF/100V electrolytic capacitors
C03	470uF/35V electrolytic capacitors
C1	475K/100V ceramic capacitance
C2	4*475K/100V ceramic capacitance
C3	2*475K/100V ceramic capacitance
LCM1	300uH/40A
CY1/CY2	3*4.7nF/Y2

Fig. 4-1

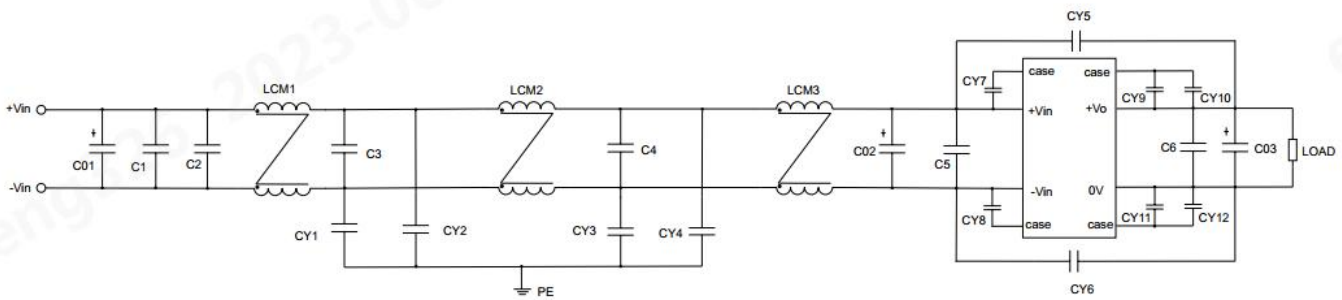

Components	Recommended Component
C01/C02	470uF/100V electrolytic capacitors
C03	3*1000uF/35V electrolytic capacitors
C1	475K/100V thin film capacitance
C2/C3/C4	225K/450V thin film capacitance
C5/C6	2*225K/450V thin film capacitance
CY1/CY2	2*4.7nF/Y2
CY3/CY4	4.7nF/Y2
CY5/CY6/CY7/CY8	1.0nF/Y1
CY9/CY11	2.2nF/Y1
CY10/CY12	4.7nF/Y2
LCM1	270uH/30A
LCM2	1.4mH/40A
LCM3	300uH/40A

Fig. 4-2

4. High temperature design reference

Recommendations for high temperature with load of the product refer to Fig 5. The maximum temperature rise of the shell should be used to evaluate the allowable load of the product under the corresponding conditions. The maximum temperature of the shell should be controlled below the corresponding horizontal coordinate temperature at the corresponding load point.

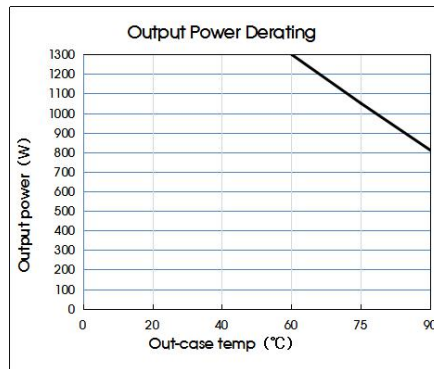

Fig. 5

5. Recommended solution for thermal testing

In the process of application, product thermal design can be evaluated by combining product temperature derating curve, or determine the stable working range of the product by testing the temperature of each temperature test point of ABCDE in Fig 6. When the temperature of each point is lower than 125°C, it is the stable working range of the product. The C is the internal temperature sampling point of the product.

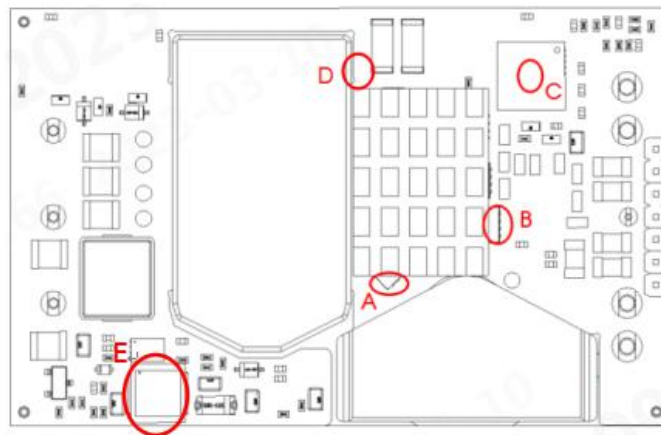

Fig. 6

6. Controllable output voltage

The output voltage must meet the following conditions: V_{out} varies with the V_{in} curve. For different input voltage V_{in} , the output voltage V_{out} must be lower than the following curve to ensure that the output voltage meets the response specifications described in the technical manual.

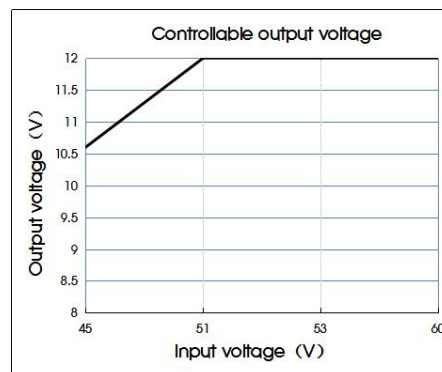

Fig. 7

7. Input start-up / turn-off voltage

The product contains an input voltage sampling circuit, which has been set to sample the input voltage, and set the input starting voltage and under-voltage turn-off voltage. Generally, the input starting voltage is set to be slightly higher than the under-voltage turn-off voltage, with a lag voltage difference of about 2VDC, in order to avoid repeated start up of the product caused by input voltage disturbance.

8. Remote Switch Control (CTRL)

The product is equipped with remote control function, the reference ground for the input power negative input terminal (-Vin), compatible with the design of negative and positive logic options, the default is negative logic, normally the CTRL pin suspended voltage is 1.6V; In cases where a control signal or switch is not required and the product is desired to be enabled automatically, the CTRL pin should be connected directly to the -Vin. The CTRL function allows the product to be turned on/off by an external device, such as a semiconductor or mechanical switch.

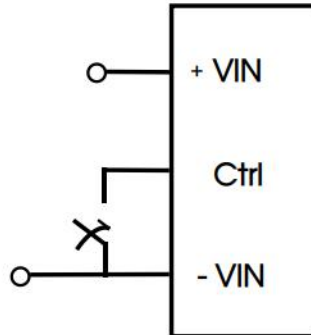

Fig. 8

External equipment must provide the minimum current absorption capacity required. 0.5 mA to ensure that the voltage of the CTRL pin meets the enable voltage specification (see Input Characteristics). Enable or disable the product by using the CTRL pin, and hold the CTRL input signal for at least $\Delta T1=1ms$.

9. For additional information please refer to DC-DC converter application notes on www.mornsun-power.com.

Power Management

1. Overview

The product is equipped with PMBus interface. The product enables power management features such as reading and configuration with fewer external components. In addition, the product includes protection to continuously protect the load from unexpected system failures that simultaneously set SALERT pins. The host can continuously monitor the following product parameters; input voltage, output voltage, output current, duty cycle, internal temperature, etc.

The product is delivered with the default configuration, suitable for the maximum range of input voltage, output voltage, load operation. The configuration is stored internally in Non-Volatile Memory (NVM). All power management functions can be reconfigured through the PMBus interface. A detailed description of each command is provided in the appendix at the end of this specification.

The Mornsun associated software suite can be used to configure and monitor the product through the PMBus interface. Contact your local Mornsun sales representative for more information.

PMBus interface

The product provides a PMBus digital interface through which users can configure devices, as well as monitor input and output voltages, output currents, and device temperatures. The product can be compatible with any standard dual-wire I2C(the master device must allow clock stretching) or PMBus host devices. For the communication protocol operation guide, refer to SMBus Specification Version 3.0. In addition, the product is compatible with PMBus version 1.3 and includes a SALERT line to help alleviate bandwidth constraints associated with continuous failure monitoring. The product only supports 100 kHz and 400 kHz bus clock frequencies. PMBus signals, SCL, SDA, and SALERT require passive pull-up resistors as specified in the SMBus specification. To ensure the rise time, a pull-up resistor is needed:

$$\tau = R_p C_p \leq 1\mu s$$

R_p is the pull-up resistance and C_p is the parasitic capacitance of the bus. For details, see "PMBus Electrical Specifications". The maximum allowable bus capacitance is 400pF. The pull-up resistor should be connected to an external power supply between 2.7-3.8V.

When communicating over PMBus, it is recommended to always use PEC(packet error checking) to increase the robustness of communication.

2. PMBus addressing

The following address resistor connection diagram and table show the recommended resistance values for the minimum and maximum voltage ranges of the PMBus address of the hardware connection. ($\pm 1\%$ tolerance resistor is recommended)

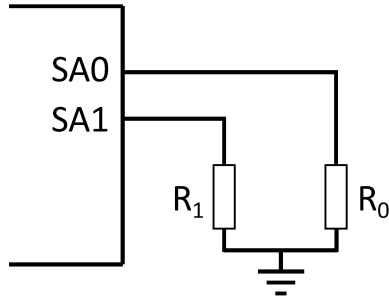

Fig. 9

SA0/SA1 Index	R ₀ (KΩ)	R ₁ (KΩ)
0	24.9	24.9
1	49.9	49.9
2	75	75
3	100	100
4	124	124
5	150	150
6	174	174
7	200	200

The PMBus address can be configured by SA0 and SA1 pins. The formula is as follows:

$$\text{PMBus address (in decimal)} = 8 \times \text{SA0 index} + \text{SA1 index}$$

If the calculated PMBus address is 0, 11, or 12, the PMBus address is assigned as 127. From a system perspective, users should also be aware of further restrictions on addresses as described in the PMBus specification. It is not recommended that pins SA0 and SA1 remain suspended.

3. I2C/SMBus -timing

See Fig. 10 below for setting and holding time timing.

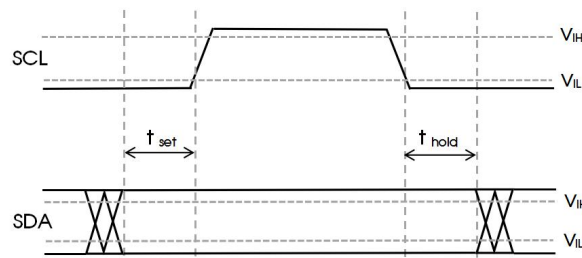

Fig. 10

Set the time t_{set} , which is the clock signal SCL rising edge before the data SDA must be stable at the time. Hold time t_{hold} , is the time after the clock SCL drops edge, the data SDA must remain stable. If these times are violated, incorrect data may be captured or instability may occur, and bus communication may fail. All standard SMBus protocols must be followed, including clock extensions. The product supports the busy flag in the status command to indicate that the product task is busy and cannot make an SMBus response. There is a 1.3μs delay between each SMBus Transfer (between each stop and start condition). For SMBus electrical and timing requirements, see the SMBus Specification. Note that in the case of storing RAM contents into internal non-volatile memory, an additional 5 ms delay must be inserted.

4. Monitoring is done through PMBus

Monitoring via PMBus. A wide variety of parameters can be continuously monitored via the PMBus interface. These parameters include but are not limited to those listed in the table below.

Parameter	PMBus Command
Input Voltage	READ_VIN
Output Voltage	READ_VOUT
Output current	READ_IOUT
Temperature	READ_TEMPERATURE_1
Switching Frequency	READ_FREQUENCY
Duty cycle	READ_DUTY_CYCLE

5. Fault monitoring

The fault state can be detected using the SALERT pin, which will be set low when any failure or warning occurs. The SALERT pin will remain low until the fault or warning is cleared by the CLEAR_FAULTS command, or until the output voltage is restarted. In response to the SALERT signal, the user can read some status commands to find out what failure or warning has occurred, as shown in the table below.

Fault or Warning Status	PMBus Command
General condition of equipment	STATUS_BYTE,STATUS_WORD
Output voltage	STATUS_VOUT
Output current	STATUS_IOUT
Input voltage	STATUS_INPUT
Temperature	STATUS_TEMPERATURE
PMBus communication	STATUS_CML

6. Nonvolatile memory (NVM)

The product contains a non-volatile memory region for storing PMBus command values. NVM preloads the Mornsun defaults, which are writable and customizable, and can be restored with the command RESTORE_DEFAULT_ALL (0x12). Values in NVM are loaded during initialization.

7. PMBus switch control (PMBus CTRL)

PMBus CTRL can be configured as a switch control through the PMBus interface. PMBus CTRL is disabled and suspended by default. The logical options controlled by PMBus CTRL can be positive or negative, and are configured using the OPERATION(0x02) command. When this feature is not used, it is recommended that the CTRL pin be connected to DGND.

8. PMBus configuration and support

The product provides a PMBus digital interface that allows users to configure devices, monitor input and output parameters, and more. The Mornsun associated software suite can be used to configure and monitor the product through the PMBus interface. Contact your local Mornsun sales representative for more information.

9. PMBus adjust the output voltage

The output voltage of the product can be reconfigured using the PMBus command VOUT_COMMAND (0x21) or VOUT_OFFSET (0x23). This can be used to adjust the output voltage above or below the initial setting of the output voltage to a certain level. See Design Reference -6 Controllable Output Voltage Curve for an understanding of the adjustable range of output characteristics. When increasing the output voltage, the input voltage must remain within the region plotted, as shown in the figure below. The output voltage setting must be kept below the over-voltage protection threshold (OVP) to prevent product downtime.

The following figure marks the adjustable range of output voltage of the product under the condition of input voltage. Within this range, it is not fully guaranteed that the output voltage characteristics of the product will respond according to the response index of the "Output Characteristics" technical manual, please refer to Figure 7. Secondly, the output voltage shall not be lower than 8V.

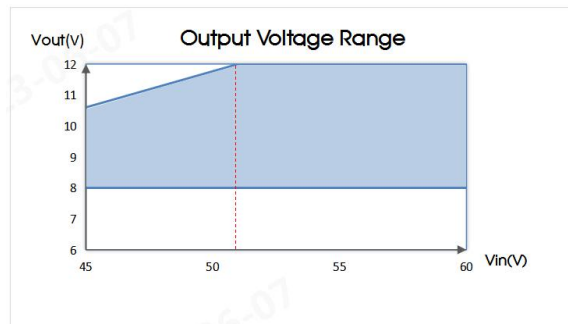

Fig. 11

10. Use CTRL/PMBus_CTRL to enable output

The default rise time for a single product is 10 milliseconds. When the input supply voltage remains constant, use the CTRL/PMBus_CTRL pin function to enable the output. The rise and fall of the output voltage and the time of the output control can be configured through the soft start and soft off functions (cannot be configured when the current is uniform). This can be used to control the starting impulse current and manage the power sequence of multiple controllers. The rise time TON_RISE (0x61) is the time it takes the output to reach its target voltage, while the fall time TOFF_FALL (0x65) is the time it takes the output to fall from its target voltage to 1V (the fall time below 1V is determined by the output load and the output capacitive load). TON_DELAY (0x60) sets the delay from output enable until output voltage begins to rise, and TOFF_DELAY (0x64) sets the delay from output disable until output voltage begins to fall.

In general, the TOFF_DELAY (0x64) command is only used to control when the output of the product is turned off by CTRL or PMBus_CTRL, and the supply voltage Vin of the product remains constant. The output voltage is turned Off by the input voltage under-voltage or over-voltage, which cannot control the Off Delay time and Off Ramp time of the down time.

When the power module is started by applying the input voltage, there is a minimum 18ms delay from the input voltage to the output voltage ($\Delta T3 - \Delta T4$, normally 40ms), which is not affected by the CTRL/PMBus_CTRL function. By default, the soft stop is off. When the output is off, the adjustment of the output voltage stops immediately. The output voltage drop time is determined by the output load and the output capacitive load. Soft shutdown performance can be enabled by using the PMBus command ON_OFF_CONFIG (0x02). You can

use the PMBus commands TON_DELAY (0x60), TON_RISE (0x61), TOFF_DELAY (0x64), and TOFF_FALL (0x65) to set the delay time and rise/fall time

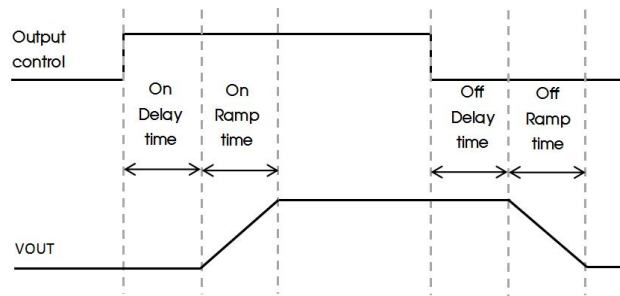

Fig. 12

11. Pre-offset start

The product has a pre-biased start function, which ensures that no current will be absorbed during start up if an unregulated pre-biased supply voltage (such as residual voltage on an output capacitive load) is present at the output. If the prebias voltage is below the target value set in VOUT_COMMAND (0x21), the product will rise to the target value. If the prebias voltage is higher than the target value set in VOUT_COMMAND (0x21), the product will gradually drop to the target value.

Do not allow the output terminal of the product to be directly connected to the output terminal of other voltage regulator devices in parallel. In this case, the pre-bias start up performance may become invalid and the parallel device may be damaged.

12. Parallel operation ACS (bus current sharing)

By default, the ACS function is configured for the VCB4812QBO-1300WR3A-N before delivery. You can get better current sharing performance on ACS-enabled products. Compared with ordinary ACS, ACS can ensure the output voltage accuracy of the product while improving the current sharing accuracy. This feature will effectively reduce the output voltage deviation, temperature deviation and layout asymmetry caused by the current sharing error. Maximum load on Parallel modules = (Maximum load on A single module 3A) x Number of parallel modules. 3A is the maximum error value of output current sampling, and the accuracy of current between products in the shared current group is $2 \times 3A$. In addition, due to the limitation of output current sampling accuracy under light load, the ACS function mainly ensures the current balancing accuracy of loads above 20%/O.

Compared with DLS, ACS can cause smaller droop, thus improving output voltage accuracy and maximum on-load power.

You are advised to perform the following steps to enable the bus balancing function: Enable the ACS function by running the MFR_OPTIONS (0xE0) command and store it in the flash by running the STORE_DEFAULT_ALL (0x11) command. After power failure, PMBus Ctrl pins (current sharing sampling) of all parallel devices are connected in series, and the devices are connected to the same load; Connect the CTRL pins of parallel devices in series to ensure that all devices start at the same time.

Note:

- ① The ACS function is not enabled during start up (i.e., during soft start up of output voltage). Therefore, the maximum load during V_o climbing is limited to 90% of the maximum load of parallel modules, that is, the number of modules * the maximum load of a single module * 90%. Therefore, in the normal flow sharing process, the maximum allowed stable flow sharing load is as follows: number of modules * Maximum load of a single module * 90%;
- ② All precautions mentioned in the DLS section are still valid when using the ACS, including negative current protection, over-current protection response, and soft start rise time;
- ③ PMBus_CTRL pins of all parallel modules should be connected together, and a ceramic capacitor should be connected between PMBus_CTRL and DGND of each module. It is recommended to configure 33nF for the MLCC of COG material;
- ④ By default, the soft off function of CTRL/PMBus_CTRL cannot be enabled when current sharing is enabled;
- ⑤ After ACS function is enabled, only the output voltage accuracy of the product is controlled, and the load adjustment rate of the product is not controlled.

13. Over-temperature Protection

The product includes an internal temperature sensor that protects the product from thermal overload. The product will shut down output when the temperature is higher than the temperature threshold set by the OT_WARN_LIMIT (0x51) command. When the temperature falls below the temperature threshold set by the OT_WARN_LIMIT (0x51) command, the product will continuously attempt to start and automatically return to normal. OTP fault limitation and fault response can be configured using PMBus.

Note:

- ① Using fault response "ignore fault" may cause permanent damage to the product.
- ② Due to the limitation of sampling points, OTP can not protect the products which are overheated due to instantaneous high power output in high temperature environment.
- ③ The recovery temperature of OTP protection has a fixed return difference of 15°C, and the recovery temperature is lower than the protection temperature of 15°C to avoid output voltage oscillation caused by temperature fluctuations at the over temperature protection point.

14. Input Under-voltage Protection

The product can be input under-voltage protection through the PMBus configuration, with response latency of 400us. This can be configured with the VIN_UV_FAULT_RESPONSE (0x5A) directive. By default, the VIN_ON (0x35) and VIN_OFF (0x36) commands are used to set the input under-voltage shutdown break point. The VIN_ON (0x35) and VIN_OFF (0x36) commands are recommended for input under-voltage protection.

Note: To avoid repeated start up of output voltage caused by input disturbance, it is recommended that the hysteretic voltage of 2V be reserved when the input start up voltage and under-voltage shutdown voltage are configured using VIN_ON (0x35) and VIN_OFF (0x36) commands corresponding to PMBus.

15. Over-voltage Protection

The product includes an output over-voltage protection function to protect the load. The default over-voltage protection threshold is 30% above the nominal output voltage. If the output voltage exceeds the threshold limit, the product can respond in different ways. The default response to an over-voltage fault is to turn off the output. The device constantly checks for the presence of the fault state and restarts when the fault state no longer exists. The over-voltage protection threshold and fault response can be configured using the PMBus interface. For details, see the PMBus command in the Appendix.

Note: The product over-voltage protection function only applies when the output voltage of the product exceeds the limit voltage. In this case, the product power level output is turned off to protect the power module and avoid secondary damage. This function cannot protect other power supply devices connected to the output end.

16. Over-current Protection

The product has a current limiting circuit for protection against continuous overload. For standard configuration, the output voltage will drop to 8V, set in the command IOUT_OC_LV_FAULT_LIMIT (0x48), and then turn off and automatically restart the output current beyond the maximum output current (max Io). When the current sharing mode is not set, there will be a continuous 8ms without over-current protection judgment, at this time Io can exceed the over-current value, but the output short-circuit protection is continuously effective, when the starter flow is likely to trigger short-circuit protection and lead to output shutdown. After the bus current-sharing function is enabled, the device will be directly turned off and locked if over-current protection occurs. You can skip the over-current protection by disabling the current-sharing function or restarting the IC.

After the overload is lifted, the product will return to normal operation. Load distribution shall be designed according to the specified maximum output short-circuit current. The over-current protection can be configured through the PMBus interface. For details, see the PMBus command in the appendix.

17. Interleave

When multiple products share the same DC input power supply, the parallel interleaving function can be used to stagger the switching time between products. This feature effectively distributes the peak current of the input power supply throughout the switching cycle, thereby reducing input capacitance requirements and efficiency losses. Parallel interleaving will also reduce ripple noise if the outputs of two or more units are paralleled.

This function requires the SYNC pins of all devices in a group to be connected in series. A group of devices that are inter left in parallel must have only one host. Other devices must be configured as slave machines. It is recommended that a 100pF capacitor be connected between SYNC and DGND of the host to reduce the influence of power level on SYNC signal, which may cause a certain phase delay. Devices to be interleaved in parallel must be configured with the same Group ID. Number is the number of parallel interleaving slave devices in each group. When number is 0, Interleave function is disabled by default, and SYNC pin multiplexing is used as Power Good function. Order is the sequence of each device. Two devices cannot be configured with the same Order. The formula for calculating phase bias is as follows. For example, if three devices need to be interleaved in parallel, set the value to 0x0020, 0x0021, and 0x0022 respectively. 0x0020 is the host.

Interleave can be configured using the PMBus interface. For details, see the appendix PMBus command Interleave (0x37). The default value is 0x0000. For more information on how to set up Interleave, see the PMBus specification.

Byte	High Byte								Low Byte							
Bit Number	7	6	5	4	3	2	1	0	7	6	5	4	3	2	1	0
Contents	Not used				Group ID				Number				Order			
Default Value	0				0				0				0			

$$Phase_offset(^{\circ}) = 360^{\circ} \times \frac{Order}{Number}$$

18. Power Good Judgment

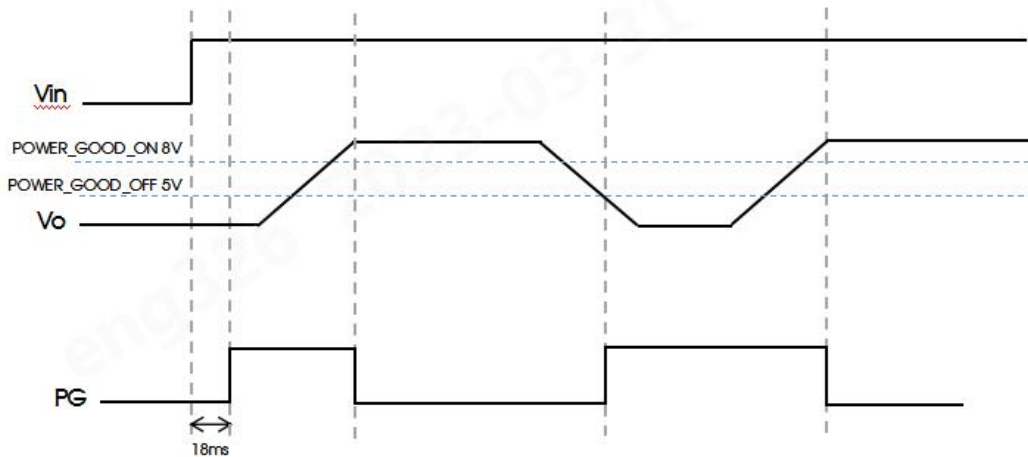

The power good pin (PG) indicates when the product is ready to provide output voltage to the load. PG remains high in the up and down state. By default, the rise time ends. If the output voltage rises above the PG threshold (typical 8V), PG is set to low. If the output voltage falls below the PG threshold (typical 5V), PG is reset. You can use the PMBus commands POWER_GOOD_ON (0x5E) and POWER_GOOD_OFF (0x5F) to change the PG threshold. PG pin defaults to push-pull output and is active at low level. By default, the PG pin is the Power Good function. When the Number of Interleave (0x37) is not 0, the PG pin is reused as the Interleave function.

If the output voltage is lower than the PG threshold and the TON_MAX_FAULT_LIMIT time persists, the start up timeout will be triggered. The device is shut down and locked. After the fault is cleared, the system recovers.

VCB4812QBO-1300WR3 Dimensions and Recommended Layout

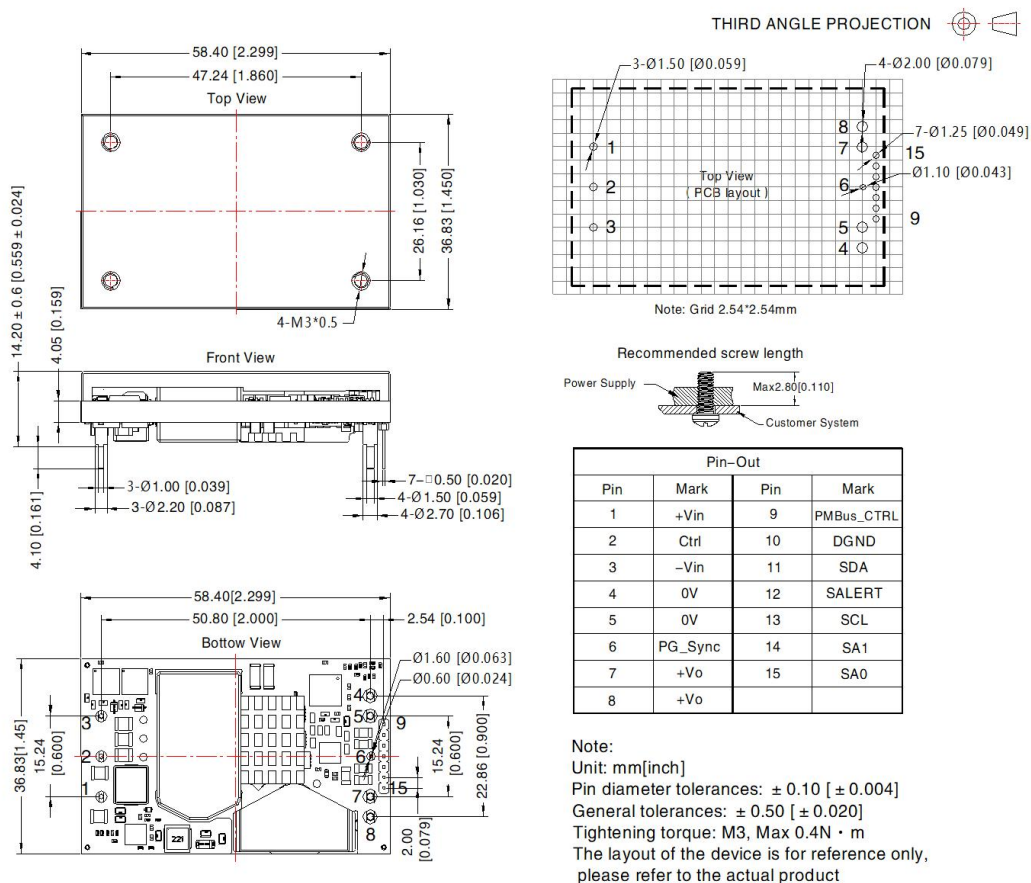

Standard configuration PMBus command summary and factory defaults

The factory defaults provided in the following table are valid for standard configurations.

Code	Command	Function	Transfer type	VCB48_QBO-1300WR3A-N			
				Default value		Default value description	
				12Vout	10.8Vout	12Vout	10.8Vout
0x01	OPERATION	Switch enable	R/W byte	0x88			
0x02	ON_OFF_CONFIG	Switch configuration	R/W Byte	0x0E			
0x03	CLEAR_FAULTS	Clear the fault	W Byte				
0x10	WRITE_PROTECT	Command write protection	R/W Byte	0x00			
0x11	STORE_DEFAULT_ALL	Store to NVM	W Byte				
0x12	RESTORE_DEFAULT_ALL	Remove from NVM	W Byte				
0x19	CAPABILITY	Equipment capacity	R Byte	0xB0			
0x20	VOUT_MODE	Output voltage data format	R Byte	0x14		Ulinear16,N=-12	
0x21	VOUT_COMMAND	Set output voltage	R/W Word	0xC000	0XACCC	12.0V	10.8V
0x23	VOUT_CAL_OFFSET	The output voltage is offset	R/W Word	0x0000		0.0V	
0x24	VOUT_MAX	Maxi output voltage can be set	R/W Word	0xD333		13.2V	
0x27	VOUT_TRANSITION_RATE	Output voltage adjustment rate	R/W Word	0x1333		1.2V/ms	
0x28	VOUT_DROOP	Droop coefficient	R/W Word				
0x32	MAX_DUTY	Set the maxi duty cycle	R/W Word	0xEB18		99%	
0x33	FREQUENCY_SWITCH	Set switching frequency	R/W Word	0xF2D0		180KHz	
0x35	VIN_ON	Set starting voltage	R/W Word	0xE2A0		42V	
0x36	VIN_OFF	Set off voltage	R/W Word	0xE280		40V	
0x37	INTERLEAVE	Parallel interleaving	R/W Word	0x0000			
0x40	VOUT_OV_FAULT_LIMIT	Output over-voltage fault value	R/W Word	0xE666		14.4V	
0x41	VOUT_OV_FAULT_RESPONSE	Output over-voltage protection action	R/W Byte	0xFC			
0x42	VOUT_OV_WARN_LIMIT	Output over-voltage alarm value	R/W Word	0xE000		14V	
0x43	VOUT_UV_WARN_LIMIT	Output under-voltage alarm value	R/W Word	0x0000		0.0V	
0x44	VOUT_UV_FAULT_LIMIT	Output under-voltage fault value	R/W Word	0x0000		0.0V	
0x45	VOUT_UV_FAULT_RESPONSE	Output under-voltage protection action	R/W Byte	0xFC			
0x46	IOUT_OC_FAULT_LIMIT	Output the over-current fault value	R/W Word	0xF21C		135A	
0x47	IOUT_OC_FAULT_RESPONSE	Output over-current protection action	R/W Byte	0xBC			
0x4A	IOUT_OC_WARN_LIMIT	Output an over-current alert value	R/W Word	0xEBC0		120A	
0x4F	OT_FAULT_LIMIT	Over-temperature fault value	R/W Word	0xEBC0		120°C	
0x50	OT_FAULT_RESPONSE	Over-temperature fault protection action	R/W Byte	0xC0			
0x51	OT_WARN_LIMIT	Over-temperature alarm value	R/W Word	0xEB70		110°C	
0x55	VIN_OV_FAULT_LIMIT	Enter the over-voltage fault value	R/W Word	0xEA30		70V	
0x56	VIN_OV_FAULT_RESPONSE	Enter the over-voltage protection action	R/W Byte	0xC0			
0x57	VIN_OV_WARN_LIMIT	Enter the over-voltage alarm value	R/W Word	0xEA08		65V	
0x58	VIN_UV_WARN_LIMIT	Enter the under-voltage alarm value	R/W Word	0xE2A0		42V	
0x59	VIN_UV_FAULT_LIMIT	Enter the under-voltage fault value	R/W Word	0xE280		40V	

Code	Command	Function	Transfer type	VCB48_QBO-1300WR3A-N			
				Default value		Default value description	
				12Vout	10.8Vout	12Vout	10.8Vout
0x5A	VIN_UV_FAULT_RESPONSE	Enter the under-voltage protection action	R/W Byte	0xC0			
0x5E	POWER_GOOD_ON	Voltage good start threshold	R/W Word	0x8000		8V	
0x5F	POWER_GOOD_OFF	Voltage good off threshold	R/W Word	0x5000		5V	
0x60	TON_DELAY	Output start up delay time	R/W Word	0xBA00		1ms	
0x61	TON_RISE	Output start up rise time	R/W Word	0xD280			without ACS is 10ms
0x62	TON_MAX_FAULT_LIMIT	Start up timeout threshold	R/W Word	0xD3C0			without ACS is 15ms
0x64	TOFF_DELAY	Output shutdown delay time	R/W Word	0xBA00		1ms	
0x65	TOFF_FALL	Output shutdown drop time	R/W Word	0xD280		10ms	
0x66	TOFF_MAX_WARN_LIMIT	Disable the descending fault threshold	R/W Word	0xD3C0		15ms	
0x78	STATUS_BYTE	Total byte read status	R Byte				
0x79	STATUS_WORD	Word read total status	R Word				
0x7A	STATUS_VOUT	Read the output voltage status	R Byte				
0x7B	STATUS_IOUT	Read the output current status	R Byte				
0x7C	STATUS_INPUT	Read the input voltage status	R Byte				
0x7D	STATUS_TEMPERATURE	Read temperature status	R Byte				
0x7E	STATUS_CML	Read command/logical status	R Byte				
0x88	READ_VIN	Read-input voltage	R Word				
0x8B	READ_VOUT	Read-output voltage	R Word				
0x8C	READ_IOUT	Read-output current	R Word				
0x8D	READ_TEMPERATURE_1	Read-temperature	R Word				
0x94	READ_DUTY_CYCLE	Read-duty cycle	R Word				
0x95	READ_FREQUENCY	Read-switch frequency	R Word				
0x98	PMBus_REVISION	Read the PMBus version number	R Byte	0x33			
0x99	MFR_ID	Read the company name	R/W Block	"MORNSUN"			
0x9A	MFR_MODEL	Read device type	R/W Block	/			
0x9B	MFR_REVISION	Read device version	R/W Block	/			
0x9C	MFR_LOCATION	Read company address	R/W Block	"Guangzhou, CN"			
0x9D	MFR_DATE	Read production date	R/W Block	/			
0x9E	MFR_SERIAL	Read serial number	R/W Block	/			
0xE0	MFR_CURRENTSHARE_OPTIONS	The current equalizing function is enabled	R/W Byte	0x00			ACS is disabled by default. You can set it to enable
0xEC	MFR_CTRL_LEVEL	Active level of CTRL pin	R/W Byte	0			CTRL is low by default
0xEF	MFR_RESTORE_OKIGIN	factory data reset	W Byte				

PMBus command detail

OPERATION (0x01)

Transfer type: R/W Byte

Function: start control and alarm control

Bit	Function	Description	Value	Function	Description
7	Enable	The device output function was enabled	1	Enable	Open output voltage
			0	Disable	Off output voltage
6	Soft Off	Set soft threshold	1	Enable Soft Off	Delay shutdown output
			0	Disable Soft Off	Direct off output
3:2	Enable Fault	Set the fault alert line	10	Enable SALERT	When a fault occurs, the SALERT line is set
			01	Disable SALERT	When a fault occurs, the SALERT line will not act

ON_OFF_CONFIG (0x02)

Transfer type: R/W Byte

Function: start-up control

Bit	Function	Description	Value	Function	Description
4	Power-on setting	Set the default power-on configuration. Whether to directly start output after power-on	1	Enable Always	Configure the CTRL pin or OPERATION command to enable output after being powered on
			0	Enable Pin or PMBus	Set output to start directly after power-on
3	OPERATION enable	Set OPERATION command	1	Enable OPERATION	Enable the OPERATION command to start output
			0	Disable OPERATION	The OPERATION command cannot be used to start the output
2	CTRL enable	Set CTRL line	1	Enable CTRL	Enable the CONTROL line control output
			0	Disable CTRL	Disable power CONTROL line to control output
1:0	CTRL level	Set the active level of CTRL	10	High	CTRL high level active
			00	Low	CTRL low level active

CLEAR_FAULTS (0x03)

Transfer type: W Byte

Function: Clear all faults

WRITE_PROTECT (0x10)

Transfer type: R/W Byte

Function: PMBus write protection

Bit	Function	Description	Value	Function	Description
7:0	Write protection	Configure write protection for some PMBus commands	0x80	Disable all	All write protection except the 0x10 command
			0x40	Enable OPERATION	All write protection except commands 0x10 and 0x01
			0x20	Enable control and Vout	All commands are write protected except 0x10, 0x01, 0x02, and 0x21
			0x00	Enable all	Disable all write protection

STORE_DEFAULT_ALL (0x11)

Transfer type: Send Byte

Function: Command the device to store its configuration in the default store

RESTORE_DEFAULT_ALL (0x12)

Transfer type: Send Byte

Function: Command the device to restore its configuration from the default storage

CAPABILITY (0x19)

Transfer type: R Byte

Function: used to read the supported functions of the device

Bit	Function	Description	Value	Function	Description
7	PEC	Whether the device supports packet error verification	1	support	
			0	Do not support	
6:5	Bus speed	Max bus speed	01	400kHz	
			00	100kHz	
4	Fault line	Whether the SALERT fault line function is available	1	With SALERT	
			0	Without SALERT	

VOUT_MODE (0x20)

Transfer type: R Byte

Function: Used to read the output voltage data format

Bit	Function	Description	Take Value	Function	Description
7: 5		Output voltage related commands support only Ulinear16 format	000	Ulinear16	Ulinear16 data format:Y=X*2 ^N
4:0	N value	Ulinear16 Indicates the N value of data	-12		

VOUT_COMMAND (0x21)

Transfer type: R/W Byte

Function: Set output voltage

Bit	Function	Format	Unit
15:0	Set the output voltage. The output voltage can not be adjusted online during the current sharing process, only allow to restart the machine after adjustment; The sagging current sharing model (VCB48_QBO-1300WR3D-N) adjusts the output voltage setting value when the load is not loaded.	Ulinear16	V

VOUT_CAL_OFFSET (0x23)

Transfer type: R/W Byte

Function: Sets the output bias voltage

Bit	Function	Format	Unit
15:0	Sets the output bias voltage	Ulinear16	V

VOUT_MAX (0x24)

Transfer type: R/W Byte

Function: Max output voltage that can be set

Bit	Function	Format	Unit
15:0	The maximum output voltage that can be set. If the voltage is set beyond this value, Will limit the output to this value, while SALERT set; ; This command can be responded during the operation of the product and corresponds to the limiting output voltage. When the output voltage during the operation of the product exceeds the value set by VOUT_MAX, it will be adjusted according to the voltage change rate set by instruction 0x27.	Ulinear16	V

VOUT_TRANSITION_RATE (0x27)

Transfer type: R/W Byte

Function: Set VOUT_COMMAND to adjust the voltage change rate of the output voltage

Bit	Function	Format	Unit
15:0	Set the voltage change rate, this command is to adjust the product working process, output voltage adjustment when the change slope. It is not allowed to adjust the output voltage during current sharing operation.	Ulinear16	V/ms

VOUT_DROOP (0x28)

Transfer type: R/W Byte

Function: Set the current sharing coefficient

Bit	Function	Format	Unit
15:0	Set the current sharing coefficient	Ulinear16	mV/A

MAX_DUTY (0x32)

Transfer type: R/W Byte

Function: Set the maximum duty cycle

Bit	Function	Format	Unit
15:0	Set the maximum duty cycle	Linear11	%

FREQUENCY_SWITCH (0x33)
Transfer type: R/W Word
Function: Set switching frequency

Bit	Function	Format	Unit
15:0	Set switching frequency. (Disallow change at output time)	Linear11	kHz

VIN_ON (0x35)
Transfer type: R/W Word
Function: Set the input voltage starting point. If the input voltage reaches this value, the device starts working and the Power Good pin is set

Bit	Function	Format	Unit
15:0	Example Set the VIN_ON threshold	Linear11	V

VIN_OFF (0x36)
Transfer type: R/W Word
Function: Set the input voltage off break point. If the input voltage reaches this value, the device stops working and the Power Good pin resets

Bit	Function	Format	Unit
15:0	Example Set the VIN_OFF threshold	Linear11	V

INTERLEAVE (0x37)
Transfer type: R/W Word
Function: Parallel interleaving is used to reduce input ripple noise when multiple devices share a DC input in parallel. You need to enable the SYNC pin of the device and connect the SYNC pins of all devices in series. Multiple devices with the same input must be set to the same Group ID. The number of staggered devices in this group should be set correctly. The staggered Order of each device must be set correctly. The Order of the devices in the group cannot be repeated. Order 0 device is the host by default and is used to send SYNC pulse, while other devices are used to receive SYNC pulse.

Bit	Function	Description	Format
11:8	Group ID	The value ranges from 0 to 15. Interleaved groups are set	/
7:4	Number	The value ranges from 0 to 15. This parameter specifies the number of interleaving devices in a group	/
3:0	Order	The value ranges from 0 to 15. This parameter specifies the sequence of the device	/

VOUT_OV_FAULT_LIMIT (0x40)
Transfer type: R/W Word
Function: Set the output over-voltage fault point. After initialization, the system starts to determine whether the output voltage is over-voltage and take corresponding protection actions.

Bit	Function	Format	Unit
15:0	Set the output over-voltage fault point. When the output voltage is higher than the voltage value, the SALERT pin will detect the fault state and be set low. The SALERT pin will keep the low level and make corresponding protection action.	Ulinear16	V

VOUT_OV_FAULT_RESPONSE (0x41)
Transfer type: R/W Byte
Function: Set the output over-voltage fault protection action

Bit	Function	Description	Take Value	Function	Description
7:6	Protective action	Hiccup protection	10	Turn off the output and try restarting	The device shuts down and responds according to the retry setting in bit (5:3).
		Turn-off protection	11	Turn-off output	Faults can be cleared in a number of ways: 1. Enable output by Ctrl/PMBus_Ctrl pin; 2. Run the OPERATION command to enable output. 3. Close and then reopen by combining the PMBus_Ctrl pin with the OPERATION command; 4. Reset the output by restarting the input power
5:3	Number of hiccups	The device attempts to restart after a hiccup. When no fault occurs, the device restarts normally. 111b indicates that the device keeps restarting	000	Hiccup 1 times	Attempts to restart the set number of times. If the restart fails, the device shuts off output.
			001	Hiccup 2 times	
			010	Hiccup 4 times	
			011	Hiccup 8 times	
			100	Hiccup 16 times	

Bit	Function	Description	Take Value	Function	Description
			101	Hiccup 32 times	The device attempts to restart until it is fault free
			110	Hiccup 64 times	
			111	Hiccup	
2:0	Time between hiccups	Set the interval between the falling edge of the hiccup and the next rising edge	0	1	Unit: 100ms
			1	2	
			2	4	
			3	8	
			4	16	
			5	32	
			6	64	
			7	128	

VOUT_OV_WARN_LIMIT (0x42)

Transfer type: R/W Word

Function: Set the output over-voltage alarm point

Bit	Function	Format	Unit
15:0	Set the output over-voltage alarm point. When the output voltage is higher than the voltage value, the SALERT pin will detect the fault state and be set low. The SALERT pin will remain low	Ulinear16	V

VOUT_UV_WARN_LIMIT (0x43)

Transfer type: R/W Word

Function: Set the output under-voltage alarm point

Bit	Function	Format	Unit
15:0	Set the output under-voltage alarm point. When the output voltage is lower than the voltage value, the SALERT pin detects the fault state and will be set to low. The SALERT pin will remain low	Ulinear16	V

VOUT_UV_FAULT_LIMIT (0x44)

Transfer type: R/W Word

Function: Set the fault point of output under-voltage. After the soft start of output voltage is complete, determine whether the output voltage is under-voltage and take corresponding protection actions.

Bit	Function	Format	Unit
15:0	Set the output under-voltage fault point. When the output voltage is lower than the voltage value, the SALERT pin will detect the fault state and be set to low. The SALERT pin will keep the low level and make corresponding protection action	Ulinear16	V

VOUT_UV_FAULT_RESPONSE (0x45)

Transfer type: R/W Byte

Function: Set the output under-voltage fault protection action

Bit	Function	Description	Take Value	Function	Description
7:6	Protective action	Hiccup protection	10	Turn off the output and try restarting	The device shuts down and responds according to the retry setting in bit (5:3).
		Turn-off protection	11	Turn-off output	Faults can be cleared in a number of ways: 1. Enable output by Ctrl/PMBus_Ctrl pin; 2. Run the OPERATION command to enable output. 3. Close and then reopen by combining the PMBus_Ctrl pin with the OPERATION command; 4. Reset the output by restarting the input power
5:3	Number of hiccups	The device attempts to restart after a hiccup. When no fault occurs, the device restarts normally, 111b indicates that the device keeps restarting	000	Hiccup 1 times	Attempts to restart the set number of times. If the restart fails, the device shuts off output.
			001	Hiccup 2 times	
			010	Hiccup 4 times	
			011	Hiccup 8 times	
			100	Hiccup 16 times	
			101	Hiccup 32 times	

Bit	Function	Description	Take Value	Function	Description
			110	Hiccup 64 times	
			111	Hiccup	The device attempts to restart until it is fault free
2:0	Time between hiccups	Set the interval between the falling edge of the hiccup and the next rising edge	0	1	Unit:100ms
			1	2	
			2	4	
			3	8	
			4	16	
			5	32	
			6	64	
			7	128	

IOUT_OC_FAULT_LIMIT (0x46)

Transfer type: R/W Word

Function: Set the output over-current fault point. After the output voltage is softly started for 8ms (2ms if the current-sharing ACS/DLS is enabled), the system starts to determine whether the output voltage is over-current and take appropriate protection actions.

Bit	Function	Format	Unit
15:0	Set the output over-current fault point. When the output current is higher than the voltage value, the SALERT pin will detect the fault state and be set low. The SALERT pin will keep the low level and make corresponding protection action	Linear11	A

IOUT_OC_FAULT_RESPONSE (0x47)

Transfer type: R/W Byte

Function: Output over-current fault response.

Bit	Function	Description	Take Value	Function	Description
		Hiccup protection	10	Turn off the output and try restarting	The device shuts down and responds according to the retry setting in bit (5:3).
7:6	Response	urn-off protection	11	Turn-off output	Faults can be cleared in a number of ways: 1. Enable output by Ctrl/PMBus_Ctrl pin; 2. Run the OPERATION command to enable output. 3. Close and then reopen by combining the PMBus_Ctrl pin with the OPERATION command; 4. Reset the output by restarting the input power
5:3	Retries	The device attempts to restart after a hiccup. When no fault occurs, the device restarts normally. 111b indicates that the device attempts to restart continuously, without limitation.	000	Hiccup 1 time	Attempts to restart the set number of times. If the restart fails, the device shuts off output.
			001	Hiccup 2 time	
			010	Hiccup 4 time	
			011	Hiccup 8 time	
			100	Hiccup 16 time	
			101	Hiccup 32 time	
			110	Hiccup 64 time	
			111	Hiccup	The device attempts to restart until it is fault free .
2:0	Delay Time	The number of delay time units, which vary depending on the type of fault. This delay time is used for either the amount of time a unit is to continue operating after a fault is detected or for the amount of time between attempts to restart.	0	1	Unit:100ms
			1	2	
			2	4	
			3	8	
			4	16	
			5	32	
			6	64	
			7	128	

IOUT_OC_WARN_LIMIT (0x4A)

Transfer type: R/W Word

Function: Output over-current warning limit.

Bit	Function	Format	Unit
15:0	Set the output over-current alarm point. When the output current is higher than the voltage value, the SALERT pin will detect the fault state and be set to low. The SALERT pin will remain low	Linear11	A

OT_FAULT_LIMIT (0x4F)

Transfer type: R/W Word

Function: After setting an over-temperature fault point, the system determines whether the monitoring point is over-temperature and takes corresponding protection actions after initialization.

Bit	Function	Format	Unit
15:0	Set the fault point of over-temperature. When the temperature of the sampling point is higher than the temperature value, the SALERT pin will detect the fault state and be set to low. The SALERT pin will keep the low level and take corresponding protection action	Linear11	°C

OT_FAULT_RESPONSE (0x50)

Transfer type: R/W Byte

Function: Over-temperature fault response.

Bit	Function	Description	Take Value	Function	Description
7:6	Response	Turn-off protection	11	When the default over temperature shutdown time is 3s and the temperature at the sampling point is 5°C lower than the over temperature fault point, restart the output.	Faults can be cleared in a number of ways: 1. Enable output by Ctrl/PMBus_Ctrl pin; 2. Run the OPERATION command to enable output. 3. Close and then reopen by combining the PMBus_Ctrl pin with the OPERATION command; 4. Reset the output by restarting the input power

OT_WARN_LIMIT (0x51)

Transfer type: R/W Word

Function: Over-temperature warning limit.

Bit	Function	Format	Unit
15:0	Set the alarm point of over temperature. When the temperature of the sampling point is higher than the temperature value, the SALERT pin will detect the fault state and be set to low, and the SALERT pin will remain low	Linear11	°C

VIN_OV_FAULT_LIMIT (0x55)

Transfer type: R/W Word

Function: Set the input over-voltage fault point. After initialization, the system determines whether the input voltage is over-voltage and takes corresponding protection actions.

Bit	Function	Format	Unit
15:0	Set the input over-voltage fault point. When the input voltage is higher than the voltage value, the SALERT pin will detect the fault state and be set low. The SALERT pin will keep the low level and make corresponding protection action.	Linear11	V

VIN_OV_FAULT_RESPONSE (0x56)

Transfer type: R/W Byte

Function: Input over-voltage fault response.

Bit	Function	Description	Take Value	Function	Description
7:6	Response	Turn-off protection	11	Turn off the output, and restart the output when the default input voltage is 5V lower than the input over-voltage fault point.	Faults can be cleared in a number of ways: 1. Enable output by Ctrl/PMBus_Ctrl pin; 2. Run the OPERATION command to enable output. 3. Close and then reopen by combining the PMBus_Ctrl pin with the OPERATION command; 4. Reset the output by restarting the input power

VIN_OV_WARN_LIMIT (0x57)

Transfer type: R/W Word

Function: Input over-voltage warning limit.

Bit	Function	Format	Unit
15:0	Set the input over-voltage alarm point. When the input voltage is higher than the voltage value, the SALERT pin will detect the fault state and be set low. The SALERT pin will remain low	Linear11	V

VIN_UV_WARN_LIMIT (0x58)

Transfer type: R/W Word

Function: Set the input under-voltage alarm point

Bit	Function	Format	Unit
15:0	Set the input under-voltage alarm point. When the input voltage is lower than the voltage value, the SALERT pin detects the fault state and will be set to low. The SALERT pin will remain low	Linear11	V

VIN_UV_FAULT_LIMIT (0x59)

Transfer type: R/W Word

Function: Set the input under-voltage fault point. After initialization, the system determines whether the input voltage is under-voltage and takes corresponding protection actions.

Bit	Function	Format	Unit
15:0	Set the input under-voltage fault point. When the input voltage is lower than the voltage value, the SALERT pin will detect the fault state and be set to low. The SALERT pin will keep the low level and make corresponding protection action. The minimum value of the specification is VIN_ON(0x35)-2V. If the value is lower than VIN_ON(0x35)-2V, the system automatically defines the value as VIN_ON(0x35)-2V. In addition, the higher values of "VIN_UV_FAULT_LIMIT" and "VIN_OFF" are used as the product under-voltage protection point.	Linear11	V

VIN_UV_FAULT_RESPONSE (0x5A)

Transfer type: R/W Byte

Function: Input under-voltage fault response

Bit	Function	Description	Take Value	Function	Description
7:6	Response	Turn-off protection	11	Turn off the output and restart the output when the default input voltage is higher than the VIN_ON value.	Faults can be cleared in a number of ways: 1. Enable output by Ctrl/PMBus_Ctrl pin; 2. Run the OPERATION command to enable output. 3. Close and then reopen by combining the PMBus_Ctrl pin with the OPERATION command; 4. Reset the output by restarting the input power

POWER_GOOD_ON (0x5E)

Transfer type: R/W Word

Function: Set the output start point to detect the start delay fault (0x62 TON_MAX_FAULT_LIMIT). If the output voltage is higher than this value, set the PG_Sync pin (Power Good) to low

Bit	Function	Format	Unit
15:0	Set the output start point	Ulinear16	V

POWER_GOOD_OFF (0x5F)

Transfer type: R/W Word

Function: If the output voltage is lower than this value, PG_Sync pin (Power Good) is set to high. During product start up, PG_Sync pin (Power Good) is set to high.

Bit	Function	Format	Unit
15:0	Set an output closing break point	Ulinear16	V

TON_DELAY (0x60)

Transfer type: R/W Word

Function: Set the start up delay time. Output ENABLE to the time when Vout starts rising. The minimum value is 1ms. The delay is directly equivalent to the delay established by enabling the output signal and output voltage using the function "Ctrl, PMBus_Ctrl, OPERATION". When the input power is restarted to enable the system, the delay is added to the start up delay. The total startup delay is 39ms+TON_DELAY.

Bit	Function	Format	Unit
15:0	Sets the start up delay time	Linear11	ms

TON_RISE (0x61)

Transfer type: R/W Word

Function: Set the rise time of start up (not adjustable when current sharing is enabled). Vout starts rising to the time it reaches Vout_COMMAND. By default, the minimum value of TON_RISE is 10ms when the stream sharing function is not enabled. When the flow balancing function (including DLS or ACS) is enabled, the minimum value of TON_RISE is 200ms.

Bit	Function	Format	Unit
15:0	Set the start up rise time	Linear11	ms

TON_MAX_FAULT_LIMIT (0x62)

Transfer type: R/W Word

Function: The maximum start up time is set. If the output voltage does not reach the value set by POWER_GOOD_ON, the fault is determined. By default, the minimum value of TON_MAX_FAULT_LIMIT is TON_RISE+10ms when the current sharing function is not enabled. When the current sharing function (including DLS or ACS) is enabled, the minimum value of TON_MAX_FAULT_LIMIT is TON_RISE+200ms.

Bit	Function	Format	Unit
15:0	The maximum start up time is set. If the value is set to 0, there is no maximum rise time. When the output voltage rise time is higher than this value, the SALERT pin will detect the fault state and be set to low, and the SALERT pin will remain low.	Linear11	ms

TOFF_DELAY (0x64)

Transfer type: R/W Word

Function: Set the shutdown delay time. When the input power supply voltage is stable, press Ctrl, PMBus_Ctrl, OPERATION to DISABLE the output and output the time between the disable signal and the start of VOUT decline.

Bit	Function	Format	Unit
15:0	Set the shutdown delay time	Linear11	ms

TOFF_FALL (0x65)

Transfer type: R/W Word

Function: Set the turn-off fall time to a minimum of 10ms. When the input power supply voltage is stable, use the Ctrl, PMBus_Ctrl, OPERATION function to turn off the output, and Vout starts to decline to a time when VOUT is lower than 1V.

Bit	Function	Format	Unit
15:0	Set the turn-off fall time	Linear11	ms

TOFF_MAX_WARN_LIMIT (0x66)

Transfer type: R/W Word

Function: Set the shutdown fall alarm value to TOFF_FALL+5ms minimum. When the input power supply voltage is stable, use "Ctrl, PMBus_Ctrl, OPERATION" to DISABLE output. The maximum time between output disable and Vout descending to POWER_GOOD_OFF is required. In this case, if the output voltage continues to be higher than POWER_GOOD_OFF during the output voltage shutdown, the output voltage remains abnormal and cannot be restored.

Bit	Function	Format	Unit
15:0	Set the shutdown down time and use the function "Ctrl, PMBus_Ctrl, OPERATION" to turn off the output. When the output voltage down time is higher than this value, SALERT pin will detect the fault state and be set to low, and SALERT pin will remain low.	Linear11	ms

STATUS_BYTE (0x78)

Transfer type: R Byte

Function: Returns the status of the device in BYTE

Bit	Function	Description	Function	Description
5	Vout over-voltage Fault	An output over-voltage fault has occurred.	1	Fault
			0	No Fault
4	Iout over-current fault	An output over-current fault has occurred.	1	Fault
			0	No Fault
3	Vin under-voltage fault	An input under-voltage fault has occurred.	1	Fault
			0	No Fault
2	OT temperature fault	A temperature fault or warning has occurred.	1	Fault
			0	No Fault
1	Communication/Logic	A communications, memory or logic fault has occurred.	1	Fault
			0	No Fault

STATUS_WORD (0x79)

Transfer type: R Word

Function: Returns device status in WORD

Bit	Function	Description	Function	Description
15	Vout	An output voltage fault or warning has occurred.	1	Fault
			0	No Fault

Bit	Function	Description	Function	Description
14	Iout	An output current fault or warning has occurred.	1	Fault
			0	No Fault
13	Vin	An input voltage, input current, or input power fault or warning has occurred.	1	Fault
			0	No Fault
5	Vout over-voltage Fault	An output over-voltage fault has occurred.	1	Fault
			0	No Fault
4	Iout over-current Fault	An output over-current fault has occurred.	1	Fault
			0	No Fault
3	Vin under-voltage Fault	An input under-voltage fault has occurred.	1	Fault
			0	No Fault
2	OT temperature fault	A temperature fault or warning has occurred.	1	Fault
			0	No Fault
1	Communication/Logic	A communications, memory or logic fault has occurred.	1	Fault
			0	No Fault

STATUS_VOUT (0x7A)

Transfer type: R Byte

Function: Returns the output voltage status of the device

Bit	Function	Description	Function	Description
7	Vout over-voltage Fault	Vout over-voltage Fault	1	Fault
			0	No Fault
6	Vout over-voltage Warning	Vout over-voltage Warning	1	Fault
			0	No Fault
5	Vout under-voltage Warning	Vout under-voltage Warning	1	Fault
			0	No Fault
4	Vout under-voltage Fault	Vout under-voltage Fault	1	Fault
			0	No Fault
3	Vout Max Warning	VOUT_COMMAND set the output voltage to value higher than VOUT_MAX	1	Fault
			0	No Fault
2	Ton Max Fault	Ton Max Fault	1	Fault
			0	No Fault
1	Toff Max Warning	Toff Max Warning	1	Fault
			0	No Fault

STATUS_IOUT (0x7B)

Transfer type: R Byte

Function: Returns the output current status of the device

Bit	Function	Description	Function	Description
7	Iout over-current Fault	Iout over-current Fault.	1	Fault
			0	No Fault
6	Iout over-current And Low Voltage Fault	Iout over-current and low voltage fault.	1	Fault
			0	No Fault
5	Iout Over Current Warning	Iout over-current Warning.	1	Fault
			0	No Fault

STATUS_INPUT (0x7C)

Transfer type: R Byte

Function: Returns the input voltage status of the device

Bit	Function	Description	Function	Description
7	Vout over-voltage Fault	Vout over-voltage Fault.	1	Fault
			0	No Fault
6	Vout over-voltage Warning	Vout over-voltage Warning.	1	Fault
			0	No Fault
5	Vout under-voltage	Vout under-voltage Warning.	1	Fault

Bit	Function	Description	Function	Description
	Warning		0	No Fault
4	Vout under-voltage Fault	Vout under-voltage Fault.	1	Fault
			0	No Fault

STATUS_TEMPERATURE (0x7D)

Transfer type: R Byte

Function: Returns the device temperature status

Bit	Function	Description	Function	Description
7	Over temperature Fault	Over temperature Fault.	1	Fault
			0	No Fault
6	Over temperature Warning	Over-temperature Warning.	1	Fault
			0	No Fault

STATUS_CML (0x7E)

Transfer type: R Byte

Function: Returns Communication/Logic/Memory-related fault status

Bit	Function	Description	Function	Description
7	Invalid Or Unsupported Command Received	Invalid Or Unsupported Command Received.	1	Fault
			0	No Fault
6	Invalid Or Unsupported Data Received	Invalid Or Unsupported Data Received.	1	Fault
			0	No Fault
5	Packet Error Check Failed	Packet Error Check Failed.	1	Fault
			0	No Fault
4	Memory Fault Detected	Memory Fault Detected.	1	Fault
			0	No Fault
1	Other Communication Fault	A communication fault other than the ones listed in this table has occurred.	1	Fault
			0	No Fault
0	Memory Or Logic Fault	Other Memory Or Logic Fault has occurred.	1	Fault
			0	No Fault

READ_VIN (0x88)

Transfer type: R Word

Function: Returns the input voltage.

Bit	Function	Format	Unit
15:0	Returns the input voltage.	Linear11	V

READ_VOUT (0x8B)

Transfer type: R Word

Function: Returns the output voltage.

Bit	Function	Format	Unit
15:0	Returns the output voltage.	Ulinear16	V

READ_IOUT (0x8C)

Transfer type: R Word

Function: Returns the measured output current.

Bit	Function	Format	Unit
15:0	Returns the measured output current.	Linear11	A

READ_TEMPERATURE_1 (0x8D)

Transfer type: R Word

Function: Returns the measured temperature (internal).

Bit	Function	Format	Unit
15:0	Returns the measured temperature (internal).	Linear11	°C

READ_DUTY_CYCLE (0x94)

Transfer type: R Word

Function: Returns the measured duty cycle in percent.

Bit	Function	Format	Unit
15:0	Returns the measured duty cycle in percent.	Linear11	%

READ_FREQUENCY (0x95)

Transfer type: R Word

Function: Return switching frequency.

Bit	Function	Format	Unit
15:0	Return switching frequency	Linear11	kHz

PMBus_REVISION (0x98)

Transfer type: R Byte

Function: Returns the PMBus revision number for this device.

Bit	Function	Value	Description
7:4	PMBus Part1Revision	0	Part 1 Revision 1.0
		1	Part 1 Revision 1.1
		2	Part 1 Revision 1.2
		3	Part 1 Revision 1.3
3:0	PMBus Part 2 Revision	0	Part 2 Revision 1.0
		1	Part 2 Revision 1.1
		2	Part 2 Revision 1.2
		3	Part 2 Revision 1.3

MFR_ID (0x99)

Transfer type: R Block

Function: Sets the Manufacturers ID

Bit	Function	Format
15:0	Sets the Manufacturers ID	ASCII

MFR_MODEL (0x9A)

Transfer type: R Block

Function: Sets the MFR MODEL string

Bit	Function	Format
15:0	Sets the MFR MODEL string	ASCII

MFR_REVISION (0x9B)

Transfer type: R Block

Function: Sets the MFR revision string

Bit	Function	Format
15:0	Sets the MFR revision string	ASCII

MFR_LOCATION (0x9C)

Transfer type: R Block

Function: Sets the MFR location string

Bit	Function	Format
15:0	Sets the MFR location string	ASCII

MFR_DATE (0x9D)

Transfer type: R Block

Function: Returns the date the regulator was manufactured

Bit	Function	Format
15:0	Returns the date the regulator was manufactured	ASCII

MFR_SERIAL (0x9E)

Transfer type: R Block

Function: Returns device serial number

Bit	Function	Format
15:0	Returns device serial number	ASCII

MFR_DLS_OPTIONS (0xE0)

Transfer type: R/W Byte

Function: Current sharing enable, disable the ACS abd DLS at the same time

Bit	Function	Value	Description
1	Enable ACS	0	Disable
		1	Enable
2	Enable DLS	0	Disable(After ACS is enabled, over-current protection is disabled.)
		1	Enable(After DLS is enabled, over-current protection will be disabled.)

MFR_CTRL_LEVEL (0xEC)

Transfer type: R/W Byte

Function: Set the active level of CTRL

Bit	Function	Value	Description
1	Set the active level of CTRL	0	The CTRL pin is active at low level
		1	The CTRL pin is active at a high level

MFR_RESTORE_OKIGIN (0XEF)

Transfer type: W Byte

Function: factory data reset

Notes:

1. For additional information on Product Packaging please refer to www.mornsun-power.com. Packaging bag number: 58010113;
2. The maximum capacitive load offered were tested at $V_{in} = 45-60\text{V}$ and full load;
3. Unless otherwise specified, parameters in this data sheet were measured under the conditions of $T_a=25^\circ\text{C}$, humidity<75%RH with nominal input voltage and rated output load;
4. All index testing methods in this data sheet are based on company corporate standards;
5. We can provide product customization service, please contact our technicians directly for specific information;
6. Products are related to laws and regulations: see "Features" and "EMC";
7. Our products shall be classified according to ISO14001 and related environmental laws and regulations, and shall be handled by qualified units.

Mornsun Guangzhou Science & Technology Co., Ltd.

Address: No. 5, Kehui St. 1, Kehui Development Center, Science Ave., Guangzhou Science City, Huang pu District, Guangzhou, P. R. China
Tel: 86-20-38601850 Fax: 86-20-38601272 E-mail: info@mornsun.cn www.mornsun-power.com