



Features

- Wide input range 100~305V AC(Class I)
- Full power output at 70~100% Constant power mode operation
- Metal case with IP67, suitable for outdoor application
- Surge protection with 6KV/4KV
- DALI-2 Dimming with minimum level 8%
- 12V/250mA Auxiliary power available(optional)
- India (EESL) version with Input Over Voltage Protection can survive input voltage stress of 440Vac for 48 hours
- Protection functions: SCP/OTP/IOVP
- Life time >50,000 hrs. and 5 years warranty

Applications

- Street lighting
- Floodlight Lighting
- Stage lighting
- Fishing lighting
- Horticulture lighting
- Bay lighting
- Type HL for use in class I, Division 2

Description

XLG-240-DA2 series is a 240W LED AC/DC driver featuring the constant power mode with DALI-2 dimming function. XLG-240-DA2 operates from 100~305VAC and offers models with different rated current ranging between 700mA and 6660mA. Thanks to the high efficiency up to 94%, with the fanless design, the entire series is able to operate for -40°C~+90°C case temperature under free air convection. The design of metal housing and IP67 ingress protection level allows this series to fit both indoor and outdoor applications. Moreover the innovative environment-adaptive capability allows this series to reliably light on the LEDs for all kinds of application environments in almost any spots that may install LED luminaires in the world. XLG-240-DA2 series comply with the latest version of IEC61347/GB19510.1 and UL8750 international safety regulations. The output and dimming circuit are also completely in accordance with the new regulations with isolation to ensure the safety of both user and luminaire system during installation.

GTIN CODE

MW Search: <https://www.meanwell.com/serviceGTIN.aspx>

Model Encoding

XLG - 240 I - L - DA2

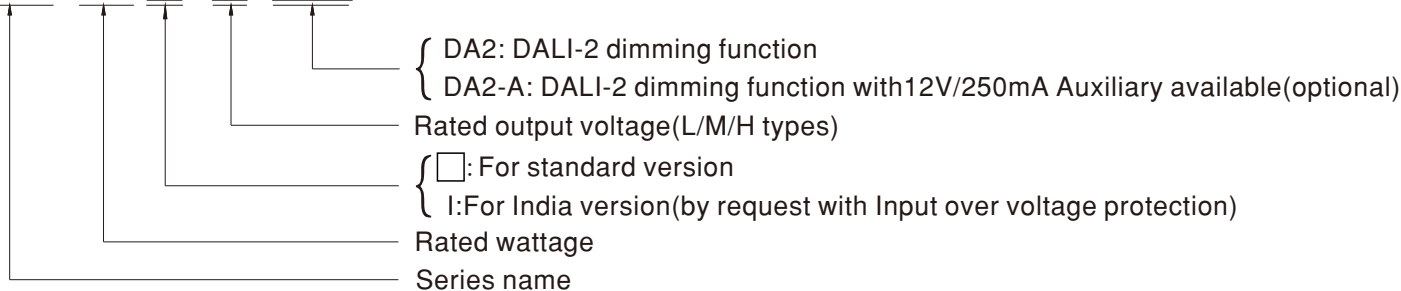

| Type | Function | Note |
|-------|---|------------|
| DA2 | DALI-2 control technology with Io adjustable via built-in potentiometer | In Stock |
| DA2-A | DALI-2 control technology with Io adjustable via built-in potentiometer and auxiliary power 12V/250mA | by request |

SPECIFICATION

| MODEL | | XLG-240□-L-□ | XLG-240□-M-□ | XLG-240□-H-□ | |
|--------------------------------|--|---|--|-------------------|--|
| OUTPUT | RATED CURRENT(Default) | 700mA | 1400mA | 4900mA | |
| | RATED POWER | 239.4W | 239.4W | 239.6W | |
| | CONSTANT CURRENT REGION Note.2 | 178 ~342V | 90 ~ 171V | 27 ~ 56V | |
| | FULL POWER CURRENT RANGE | 700~1050mA | 1400~2100mA | 4280~6660mA | |
| | OPEN CIRCUIT VOLTAGE (max.) | 380V | 197V | 65V | |
| | CURRENT ADJ. RANGE | (Via the built-in potentiometer) | | | |
| | | 350~1050mA | 700~2100mA | 2400~6660mA | |
| | CURRENT RIPPLE | 5%(@ full load) | | | |
| | CURRENT TOLERANCE | ±5% | | | |
| | AUXILIARY DC OUTPUT | 12V@250mA tolerance ±10%, ripple 200mVp-p (only for DA2-A-type) | | | |
| SET UP TIME | 500ms/230VAC, 1200ms/115VAC | | | | |
| INPUT | VOLTAGE RANGE Note.4 | 100 ~ 305VAC 142VDC ~ 431VDC (Please refer to "STATIC CHARACTERISTIC" ang " DRIVING METHODS OF LED MODULE"section) | | | |
| | FREQUENCY RANGE | 47 ~ 63Hz | | | |
| | POWER FACTOR (Typ.) | PF ≥ 0.97 / 115VAC, PF ≥ 0.95 / 230VAC, PF ≥ 0.92 / 277VAC at full load (Please refer to "Power Factor Characteristic" section) | | | |
| | TOTAL HARMONIC DISTORTION | THD < 10% (@ load ≥ 50% at 115VAC/230VAC ,@load ≥ 75% at 277VAC) Please refer to "TOTAL HARMONIC DISTORTION (THD)" section | | | |
| | EFFICIENCY (Typ.) Note.14 | 94% | 93.5% | 93% | |
| | AC CURRENT (Typ.) | 2.7A / 115VAC 1.3A / 230VAC 1.1A/277VAC | | | |
| | INRUSH CURRENT(Typ.) | COLD START 85A(twidth=500μs measured at 50% Ipeak) at 230VAC; Per NEMA 410 | | | |
| | MAX. NO. of PSUs on 16A CIRCUIT BREAKER | 2 unit(circuit breaker of type B) / 4 units(circuit breaker of type C) at 230VAC | | | |
| | LEAKAGE CURRENT | <0.75mA / 277VAC | | | |
| | STANDBY POWER CONSUMPTION | Standby power consumption <0.5W (Dimming OFF, Only for standard version DA2-type) | | | |
| PROTECTION | SHORT CIRCUIT | Hiccup mode or Constant current limiting, recovers automatically after fault condition is removed | | | |
| | INPUT OVER VOLTAGE Note.7 | 320 ~ 390VAC (Shut down output voltage when the input voltage exceeds protection voltage,recovers automatically after fault condition is removed) Can survive input voltage stress of 440Vac for 48 hours | | | |
| | OVER TEMPERATURE | Stage 1: Derating to 75% loading; stage 2: Derating to 50% loading. recovers automatically after fault condition is removed | | | |
| ENVIRONMENT | WORKING TEMP. | Tcase=-40 ~ +90°C(Please refer to "OUTPUT LOAD vs TEMPERATURE" section) | | | |
| | MAX. CASE TEMP. | Tcase=+90°C | | | |
| | WORKING HUMIDITY | 20 ~ 95% RH non-condensing | | | |
| | STORAGE TEMP., HUMIDITY | -40 ~ +80°C, 10 ~ 95% RH non-condensing | | | |
| | TEMP. COEFFICIENT | ±0.06%/°C (0 ~ 60°C) | | | |
| | VIBRATION | 10 ~ 500Hz, 5G 12min./1cycle, period for 72min. each along X, Y, Z axes | | | |
| SAFETY & EMC | SAFETY STANDARDS | UL8750(type"HL"), CSA C22.2 No. 250.13-12; ENEC BS EN/EN61347-1, BS EN/EN61347-2-13 (EL) appendix J suitable for emergency installations(DC Input: 176-280Vdc) independent , GB19510.1 , GB19510.14; EAC TP TC 004; IP67 approved | | | |
| | DALI STANDARDS | Comply with IEC62386-101,102,207,251,Device type 6(DT6) | | | |
| | WITHSTAND VOLTAGE | I/P-O/P:3.75KVAC I/P-FG:2KVAC O/P-FG:1.8KVAC | | | |
| | ISOLATION RESISTANCE | I/P-O/P, I/P-FG, O/P-FG:100M Ohms / 500VDC / 25°C / 70% RH | | | |
| | EMC EMISSION | Parameter | Standard | Test Level/Note | |
| | | Conducted | BS EN/EN55015(CISPR15) ,GB/T17743 | ----- | |
| | | Radiated | BS EN/EN55015(CISPR15) ,GB/T17743 | ----- | |
| | | Harmonic Current | BS EN/EN61000-3-2 ,GB/T17625.1 | Class C @load≥50% | |
| | | Voltage Flicker | BS EN/EN61000-3-3 | ----- | |
| | EMC IMMUNITY | Parameter | Standard | Test Level/Note | |
| ESD | | BS EN/EN61000-4-2 | Level 3, 8KV air ; Level 2, 4KV contact | | |
| Radiated | | BS EN/EN61000-4-3 | Level 2 | | |
| EFT/Burst | | BS EN/EN61000-4-4 | Level 3 | | |
| Surge | | BS EN/EN61000-4-5 | 4KV/Line-Line 6KV/Line-Earth | | |
| Conducted | | BS EN/EN61000-4-6 | Level 2 | | |
| Magnetic Field | | BS EN/EN61000-4-8 | Level 4 | | |
| Voltage Dips and Interruptions | | BS EN/EN61000-4-11 | >95% dip 0.5 periods, 30% dip 25 periods, >95% interruptions 250 periods | | |
| OTHERS | MTBF | 1988.7K hrs min. Telcordia SR-332 (Bellcore) ; 170.5K hrs min. MIL-HDBK-217F (25°C) | | | |
| | DIMENSION | 219*63*35.5mm (L*W*H) | | | |
| | PACKING | 1Kg;16pcs/16Kg/0.80CUFT | | | |
| NOTE | <ol style="list-style-type: none"> All parameters NOT specially mentioned are measured at 230VAC input, rated current and 25°C of ambient temperature. Please refer to "DRIVING METHODS OF LED MODULE". Tolerance : includes set up tolerance, line regulation and load regulation. De-rating may be needed under low input voltages. Please refer to "STATIC CHARACTERISTIC" sections for details. Length of set up time is measured at first cold start. Turning ON/OFF the driver may lead to increase of the set up time. Especially when the temperature inside driver is very high, it will lead to a longer set up time. Based on IEC 62386-101/102 DALI power on timing and interruption regulations,the set up time needs to test with a DALI controller which can support for DALI power on function,otherwise the set up time will be longer than 500ms. Input over voltage only for XLG-240 I series,and I series without UL/CSA certificate. The driver is considered as a component that will be operated in combination with final equipment. Since EMC performance will be affected by the complete installation, the final equipment manufacturers must re-qualify EMC Directive on the complete installation again. The ambient temperature derating of 3.5°C/1000m with fanless models and of 5°C/1000m with fan models for operating altitude higher than 2000m(6500ft). Please refer to the warranty statement on MEAN WELL's website at http://www.meanwell.com This series meets the typical life expectancy of >50,000 hours of operation when Tcase, particularly (Tc) point (or TMP, per DLC), is about 75°C or less. Products sourced from the Americas regions may not have the CCC/PSE/BIS/KC logo. Please contact your MEAN WELL sales for more information. For any application note and IP water proof function installation caution, please refer our user manual before using. https://www.meanwell.com/Upload/PDF/LED_EN.pdf The efficiency will drop 1% based on auxiliary power version with full load 3W condition. H type: RCM is on a voluntary basis. Non IC classification Independent LED control gear is not suitable for residential installations. ML type: RCM is on a voluntary basis and meets relevant IEC or AS/NZS standards complying with AS/NZS 4417.1 <p>※ Product Liability Disclaimer : For detailed information, please refer to https://www.meanwell.com/serviceDisclaimer.aspx</p> | | | | |

■ BLOCK DIAGRAM

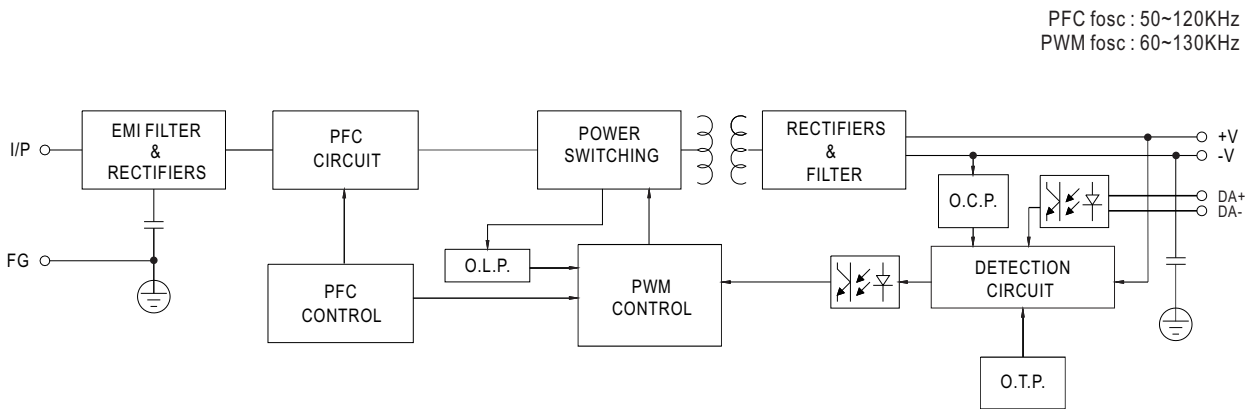

■ DRIVING METHODS OF LED MODULE

※ I-V Operating Area

◎ XLG-240-L-DA2

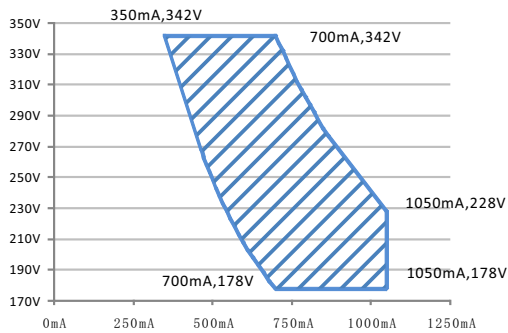

◎ XLG-240-M-DA2

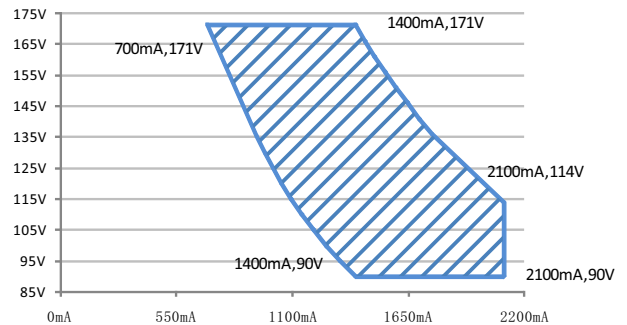

Recommend Performance Region

Recommend Performance Region

◎ XLG-240-H-DA2

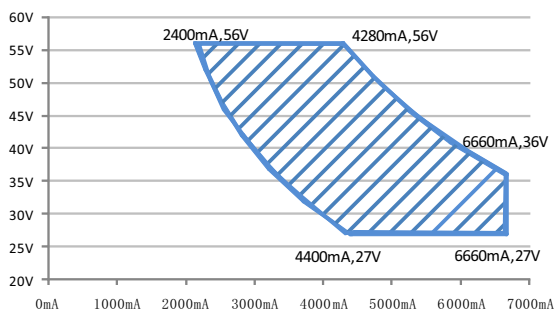

Recommend Performance Region

DIMMING OPERATION

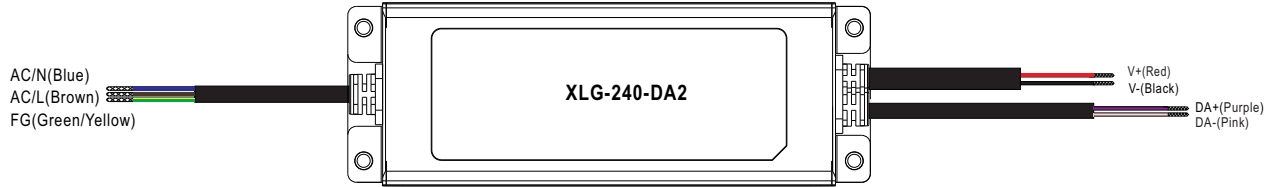

※ DALI Interface

- Apply DALI signal between DA+ and DA-.
- DALI protocol comprises 16 groups and 64 addresses.
- First step is fixed at 8% of output.

OUTPUT LOAD vs TEMPERATURE

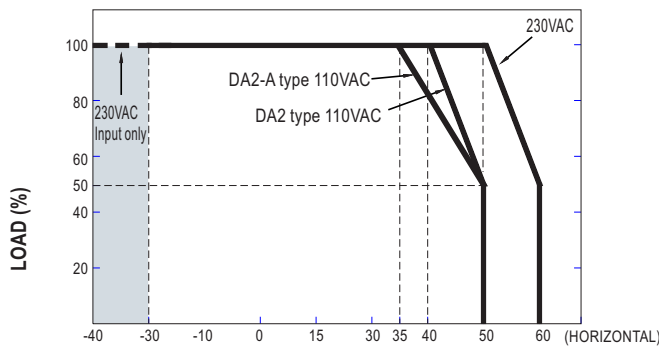

AMBIENT TEMPERATURE, T_a (°C)

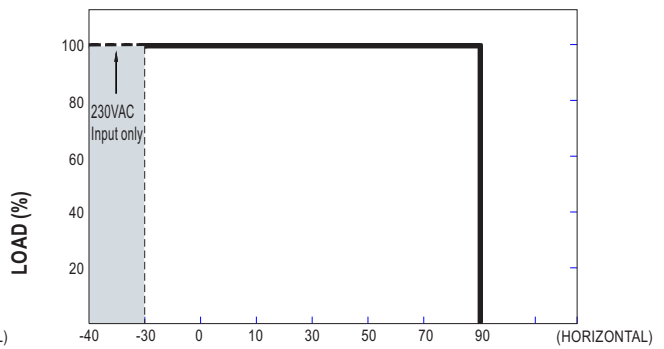

T_{case} (°C)

- Note: 1. The output current must be derated at ultra-high ambient temperature.
 2. Below 120VAC@-30°C may have restart situation within 5s after power-on.

STATIC CHARACTERISTIC

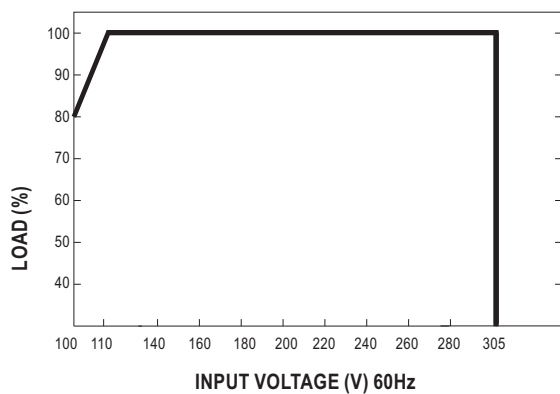

POWER FACTOR (PF) CHARACTERISTIC

※ T_{case} at 75°C

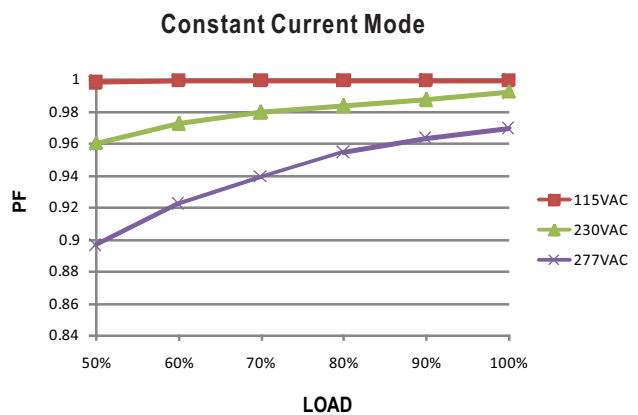



TOTAL HARMONIC DISTORTION (THD)

※ XLG-240-L-DA2 Model, Tcase at 75°C

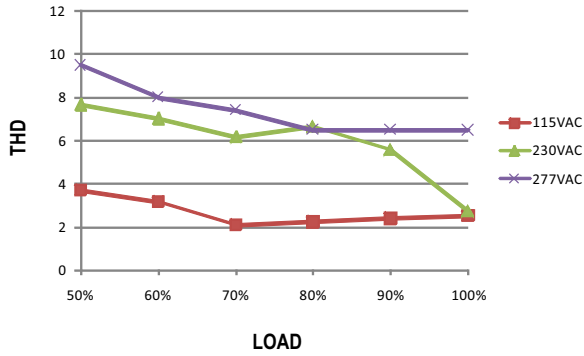

EFFICIENCY vs LOAD

XLG-240-DA2 series possess superior working efficiency that up to 93% can be reached in field applications.

XLG-240-L-DA2 Model, Tcase at 75°C

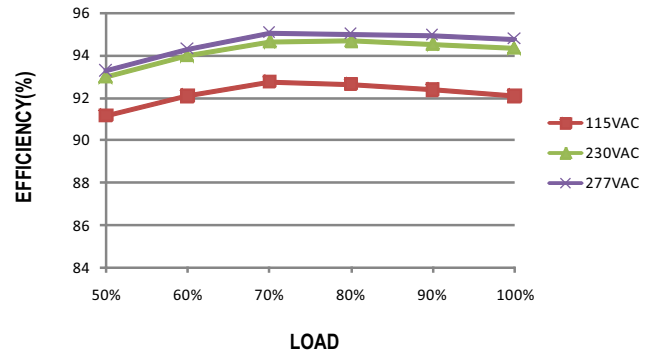

LIFE TIME

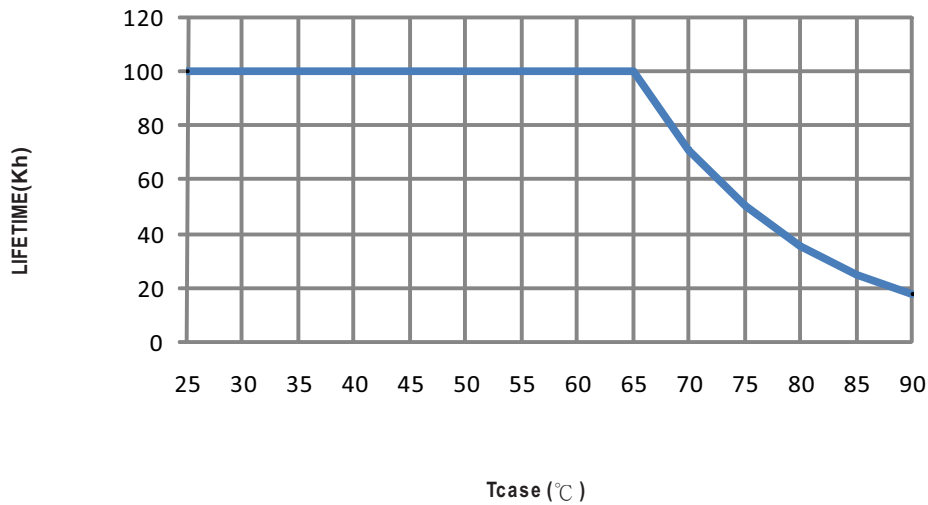

MECHANICAL SPECIFICATION

Case No.: 237 Unit:mm

※ DA2-Type

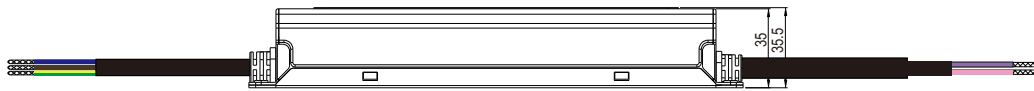
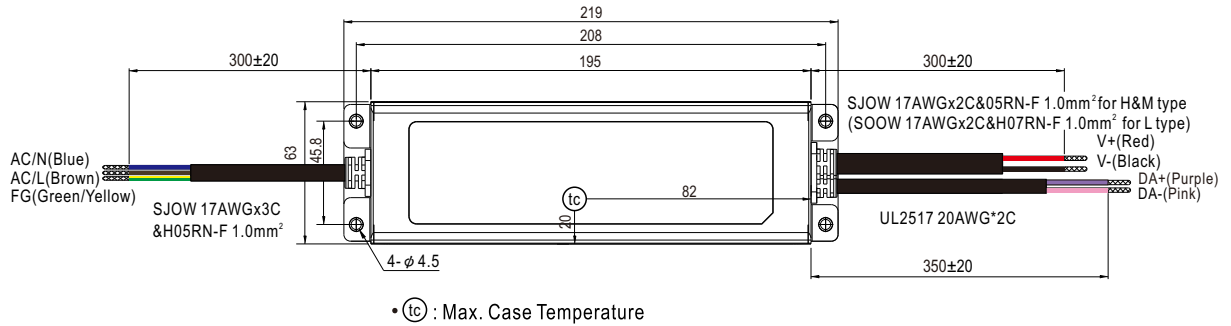

※ DA2-A-Type (by optional)

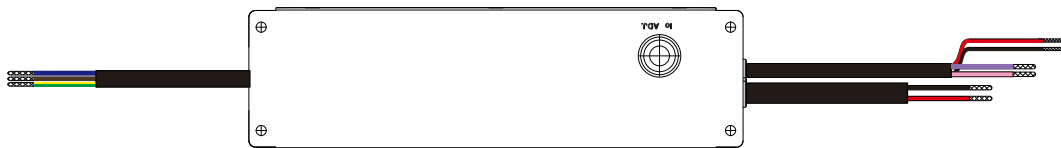
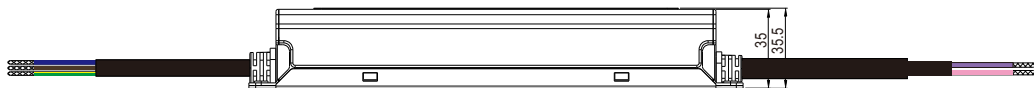
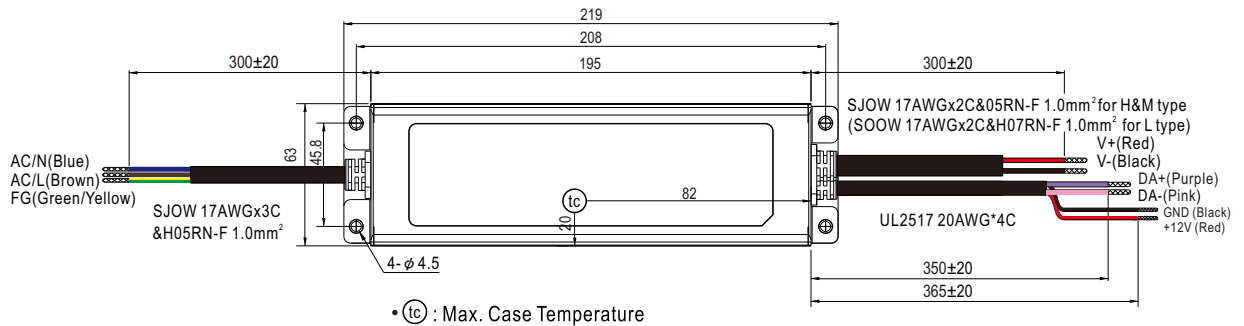

INSTALLATION MANUAL

Please refer to : <http://www.meanwell.com/manual.html>